

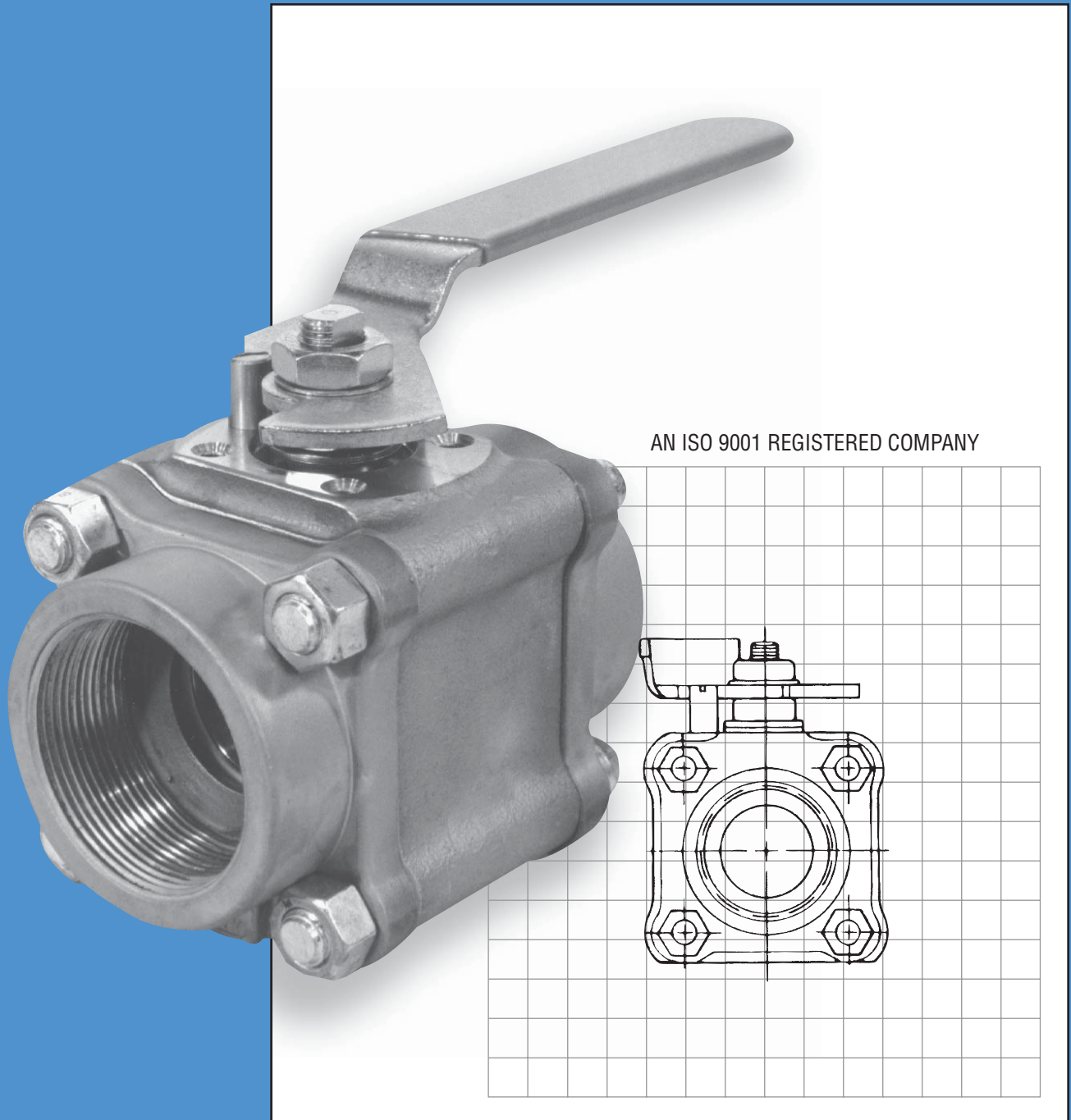

Worcester Controls

FCD WCABR1011-00
(Part PB 451)



AN ISO 9001 REGISTERED COMPANY

Series 59 Full-Port Ball Valve

*Full-port valves offer maximum capacity,
minimum restriction, optional fire-rated design*

Series 59 Full-Port Ball Valves

Manual and automated valves for processes requiring maximum flow area

Full-port ball valves are recommended for processes requiring minimum restriction through piping, shutoff valves, and other equipment. For example, pump inlet valves are often full-port valves. Full-port valves are also useful in systems handling slurries, viscous fluids and fluids with residues, and where the capacity to pig lines is desired.

1/4"- 2" Series 59 valves are rated to ANSI Class 600. 3" and 4" valves are rated to ANSI Class 300.

Worcester offers a complete line of pneumatic and electric automation packages for on/off or throttling control, including the Series 39 twin piston pneumatic actuator and the Series 75 electric actuator.

Series 59 full-port valves are available in a fire-rated configuration AF59 in sizes 1/2", 3/4", 1", 1 1/2", and 2". Flanged ANSI Class 150 and 300 full-port valves are available in sizes 1/2" - 10".

Specifications

- Sizes:** 1/4", 3/8", 1/2", 3/4", 1", 1 1/4", 1 1/2", 2", 3", 4"
- Style:** Three-piece, four-bolt (1/4"- 2")
Three-piece, eight-bolt (3"- 4")
- Valve Pressure Rating*:** 1/4" - 2" Carbon Steel and Stainless Steel Valves, ANSI Class 600
3"- 4" Carbon Steel and Stainless Steel Valves, ANSI Class 300
1/4"- 1" Brass Valves, 1500 psi
1 1/4"- 1 1/2" Brass Valves, 1000 psi
- Body:** Carbon Steel, 316 Stainless Steel, Brass (valve sizes 1/4" - 1 1/2")
- Pipe Ends:** Screw End, Socket Weld, Butt Weld, Tube End
- Ball:** Chrome Plated Brass
316 Stainless Steel
- Temp. Range:** Depends on seat and seal choice; will operate from -20°F to +600°F
- Seat/Seal Leakage:** Standard valves, less than 1 x 10⁻⁶ cc He/sec inboard and through (bubbletight is 1 x 10⁻⁴ cc He/sec). With preparation, leakage will be less than 2 x 10⁻⁹ cc He/sec. All valves 100% tested to bubbletight standards.
- Flow:** Bidirectional

* These are valve body pressure ratings. Seat selection may derate the valve.
Example: a 1" carbon steel Series 59 valve has a rating of 1480 psi at 70°F.
Selection of reinforced TFE seats operating at fluid temperature of 200°F limits allowable pressure in the valve to 1000 psi.

Flow Coefficient

Flow coefficient and pressure loss through full-port ball valves are the same as the pipe they are attached to.

Valve Size	C _v	Equiv. Length of Sched. 40 pipe (ft)	Valve Size	C _v	Equiv. Length of Sched. 40 pipe (ft)
1/4", 3/8"	8	0.9	1 1/4"	230	2.1
1/2"	38	1.4	1 1/2"	350	2.1
3/4"	71	1.0	2"	600	2.1
1"	110	1.9	3"	1330	3.0
			4"	2420	2.7

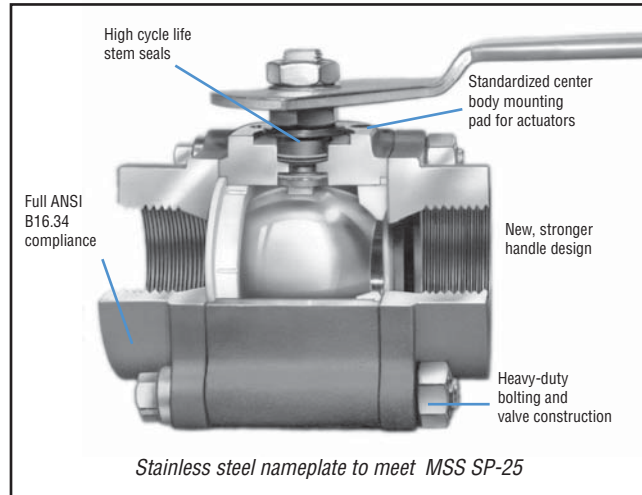

- Design Specifications:** ANSI B16.34 (1/4"- 2", if ordered with Hydro Test)
ANSI B16.25 – Butt Weld Ends (Weld End Preparation)
ANSI B16.11
ANSI B1.20.1 – NPT Pipe Threads
MSS SP25 – Valve Marking
MSS SP72 – Socket Weld Ball Valves
NACE – MRO 1-75 Category 3
- UL Listed: (1/4"- 2")** Flammable liquid shutoff (YRBX)
Anhydrous ammonia shutoff (YQAR)
Compressed gas shutoff, including oxygen (YQNZ)
Trim and drain valves (VQGU)
- Weld-in-Place Valves (V67):** 1/4"- 1 1/2" Series 59 valves with "G" body seals and seats of reinforced TFE (R), Polyfill® (P), or High-per Fill® (X) may be welded to the pipeline in the assembled condition. (Must have V67 suffix in ordering code).
- Optional S-7:** (1/4"- 1 1/2") Complete stainless steel trim: handle, nut, lock washer, retaining nut, Belleville washers, body bolts, nuts, stop pin.
- External Valve Trim:** External components are available as an option on brass and carbon steel valves. They are standard on 1/4"- 1 1/2" stainless steel valves. For 2"- 4", they are available through custom products. Certified Material Testing Reports (CMTRs) are available with B16.34.

Variations (V#)

- V3 Upstream Relief Hole
- V5 Hydrostatic Testing
- V6 Source Inspection
- V14 Handleless Valve (2"- 4")
- V17 Grounding Thrust Bearing
- V20 Oxygen Service
- V32 Oval Handle (1/4"- 1 1/2")
- V33 Oxygen Service without Source Inspect.
- V36 Certificate of Compliance
- V37 Certificate of Compliance & Hydro Testing
- V38 Assemble without Lubricant
- V46 Silicon Free Lubricant
- V48 Extended Lever Handle (1/4"- 1 1/2")
- V51 High Cycle Stem Build (2"- 4")
- V58 B16.34 Compliance
- V59 Extended Oval Handle (1/4"- 1 1/2")
- V60 OSHA Lockout (1/4"- 1 1/2")
- V66 Cert. of Comp., European orders
- V67 Weld-in-Place Valve (1/4"- 1 1/2")
- V72 Cert. of Comp., European Pressure Equipment Directive Conformance

Parts Identification and Material Specifications

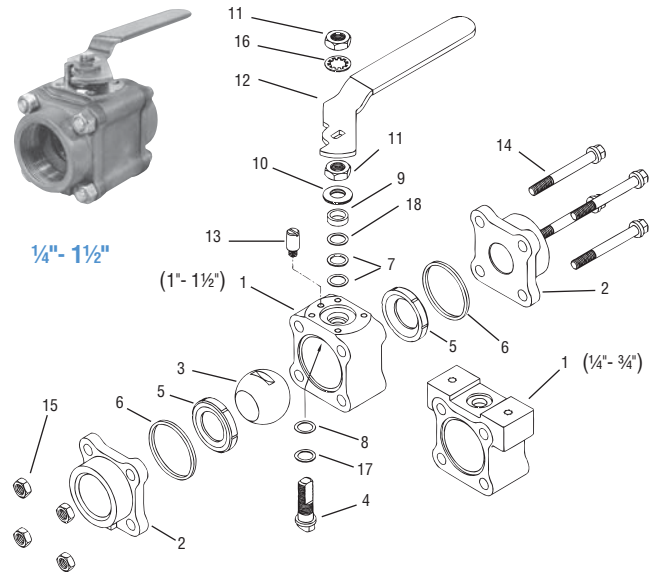
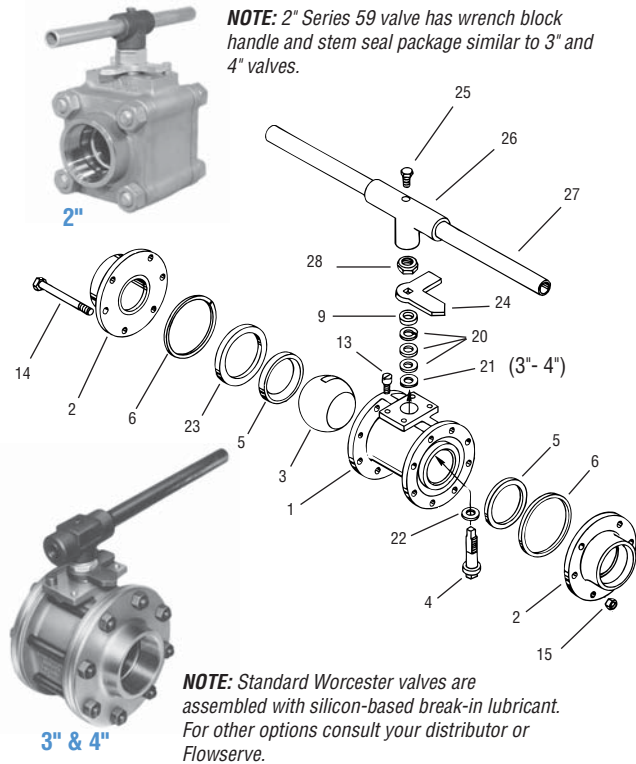

No.	Part	Qty	Material
1	Body	1	C.S., 316 S.S., Brass
2	Pipe End	2	C.S., Brass, 316 S.S., (316L for weld ends)
3	Ball	1	316 S.S., Chrome-Plated Brass
4	Stem	1	316 S.S., Brass
5	Seat	2	TFE, Reinforced TFE, Buna, Neoprene, Polyfill, UHMWPE, High-per Fill, Delrin®AF
6	Body Seal	2	Buna, Viton®, EPR, TFE, Neoprene, TFE Coated 316 S.S. "S" Gasket, Graphite Coated 316 S.S. "S" Gasket, UHMWPE Graphite (2" only)
7	Stem Seal	2	Polyfill (UHMWPE with UHMWPE seats; Graphite with High-per Fill Seats)
8	Thrust Bearing	1	Polyfill (UHMWPE with UHMWPE seats; PEEK with High-per Fill seats; Delrin with Delrin AF seats)
9	Stem Seal Follower	1	316 S.S.
10	Belleville Washers	2	Carbon Steel: Zinc-Plated or S.S.
11	Retaining Nut	2	Carbon Steel: Zinc-Plated or S.S.
12	Handle Assembly	1	Carbon Steel: Zinc-Plated or S.S. Vinyl Sleeve
13	Stop Pin (1" and up) (1/4"- 3/4")	1 2	1/4"- 1/2" S.S. or C.S. Zinc-Plated; 2"- 4" C.S., Black Oxide-Coated
14	Body Bolts	4 8	1/4"- 2" C.S.: ASTM A193 GR-B7 S.S.: ASTM A193 GR-B8 3"- 4" C.S.: Black Oxide-Coated
15	Body Nuts	4 8	1/4"- 2" C.S.: ASTM A194 GR-2H S.S.: ASTM A194 GR-B8 3"- 4" C.S.: Black Oxide-Coated
16	Lockwasher	1	Carbon Steel: Zinc-Plated or S.S.
17	Thrust Bearing*	1	PEEK (UHMWPE with UHMWPE seats; Delrin with Delrin AF seats)
18	Seal Protector*	1	PEEK
19	Nameplate (not shown)	1	304 Stainless Steel
20	Stem Seal	3	Size 2", 3", 4" Valves Glass-filled TFE
21	Centering Washer	1	C.S., 316 S.S. (3" & 4" only)
22	Thrust Bearing	1	Glass-filled TFE
23	Seat Retainer	1	Carbon Steel or 316 S.S.
24	Stop	1	C.S.: Black Oxide-Coated
25	Hex. Head Bolt	1	Carbon Steel
26	Wrench Block	1	Malleable Iron
27	Wrench Extension	1	Carbon Steel
28	Retaining Nut	1	Carbon Steel: Zinc-Plated or S.S.

Seat Pressure/Temperature Ratings

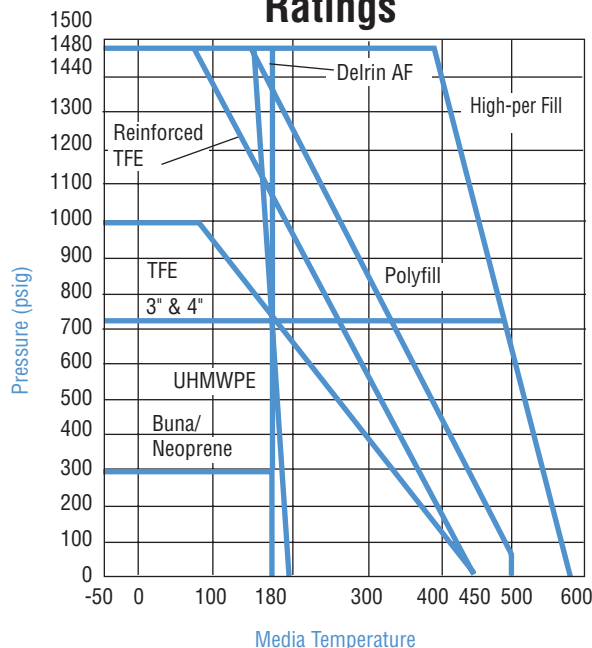

Body seals have a pressure/temperature rating that equals or exceeds the seat.
* Oxygen Service Valves use Polyfill in place of PEEK.

Dimensions

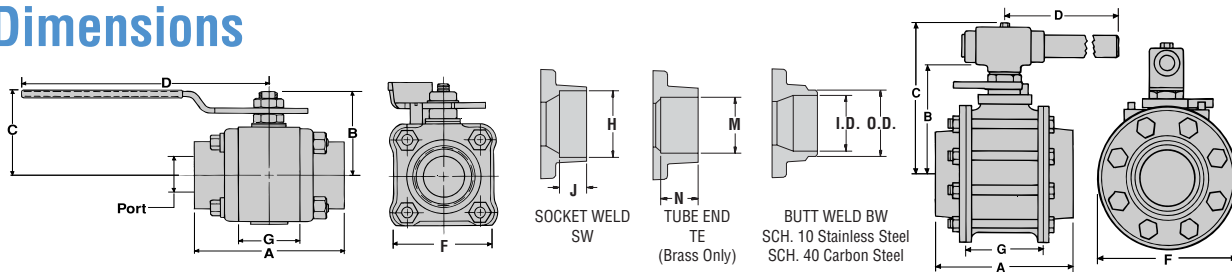

Valve Size	A	B	C	D	F	G	Socket Weld		Tube End		Butt Weld Scheduled 10		Butt Weld Scheduled 40		Port	Weight lb. (kg)
							H	J	M	N	O.D.	I.D.	O.D.	I.D.		
1/4"	2.54 (64.52)	1.55 (39.4)	1.76 (44.7)	5.53 (140.5)	1.75 (44.5)	.813 (20.7)	.555 (14.1)	.440 (11.2)	.378 (9.6)	.370 (9.4)	.550 (14.4)	.406 (10.3)	.550 (14.4)	.344 (8.7)	.440 (11.2)	1.10 (0.5)
3/8"	2.54 (64.52)	1.55 (39.4)	1.76 (44.7)	5.53 (140.5)	1.75 (44.5)	.813 (20.7)	.690 (17.5)	.440 (11.2)	.504 (12.8)	.449 (11.2)	.670 (17.0)	.547 (13.9)	.670 (17.0)	.516 (13.1)	.440 (11.2)	1.10 (0.5)
1/2"	2.76 (70.1)	1.64 (41.7)	1.86 (47.24)	5.53 (140.5)	2.00 (50.8)	.969 (24.6)	.855 (21.7)	.440 (11.2)	.628 (15.6)	.560 (14.2)	.840 (21.3)	.672 (17.1)	.840 (21.3)	.625 (15.9)	.560 (14.2)	1.80 (0.82)
3/4"	3.66 (92.96)	2.19 (55.6)	2.28 (57.91)	6.53 (165.9)	2.38 (60.5)	1.25 (31.8)	1.07 (27.1)	.560 (14.2)	.878 (22.3)	.810 (20.6)	1.05 (26.7)	.875 (22.2)	1.05 (26.7)	.812 (20.6)	0.81 (20.6)	3.10 (1.41)
1"	4.16 (105.7)	2.38 (60.5)	2.47 (62.74)	6.53 (165.9)	2.70 (68.6)	1.63 (41.3)	1.33 (33.8)	.720 (18.3)	1.13 (28.7)	.97 (24.6)	1.31 (33.3)	1.09 (27.8)	1.31 (33.3)	1.05 (26.6)	1.00 (25.4)	4.50 (2.05)
1 1/4"	4.50 (114.3)	2.88 (73.2)	2.83 (71.88)	8.03 (204.0)	3.16 (80.3)	1.91 (48.4)	1.68 (42.5)	.720 (18.3)	1.38 (35.0)	1.03 (25.2)	1.66 (42.2)	1.44 (36.5)	1.66 (42.2)	1.38 (35.1)	1.25 (31.8)	6.20 (2.81)
1 1/2"	4.94 (125.5)	3.06 (77.7)	3.02 (76.71)	8.03 (224.0)	3.56 (90.4)	2.22 (56.3)	1.92 (48.6)	.720 (18.3)	1.63 (41.4)	1.15 (29.2)	1.91 (48.5)	1.67 (42.5)	1.91 (48.5)	1.59 (40.5)	1.50 (38.1)	9.50 (4.31)
2"	5.86 (149.0)	4.56 (116)	5.58 (142.0)	8.82 (224.0)	4.57 (116.0)	2.86 (72.6)	2.41 (61.2)	.840 (21.34)	—	—	2.38 (60.5)	2.15 (54.5)	2.38 (60.5)	2.06 (52.3)	2.00 (50.8)	25.00 (11.3)
3"	7.54 (191.0)	6.31 (160.3)	7.84 (199.0)	22.00 (558.8)	8.13 (206.0)	4.28 (108.0)	3.54 (89.9)	1.31 (33.27)	—	—	3.50 (88.9)	3.25 (82.55)	3.50 (88.9)	3.07 (77.98)	3.25 (82.55)	50.20 (22.8)
4"	11.75 (298.0)	8.96 (227.9)	11.21 (284.0)	26.00 (660.0)	11.13 (282.0)	5.75 (146.0)	4.53 (115.1)	1.56 (39.62)	—	—	4.50 (114.3)	4.26 (108.2)	4.50 (114.3)	4.03 (102.4)	4.03 (102.4)	80.10 (36.4)

Dimensions are given for layout purposes only. For tolerances, consult your Worcester distributor. Metric equivalents are converted from Standard English.

How To Order*

Size	Options	Series	Body, Pipe Ends	Ball & Stem	Seat	Body Seal	Pipe End	V#
1 1/2"		59	1 - Brass (1/4" - 1 1/2" only) 4 - Carbon Steel 6 - 316 S.S.	1 - Brass 6 - 316 S.S.	T - TFE R - Reinforced TFE U - UHMWPE (1/4" - 1 1/2" only)	T - TFE B - Buna (Brass only) V - Viton E - EPR M - TFE coated 316 S.S. "S" gasket	SE - Screw End SW - Socket Weld TE - Tube End (Brass Only) BW1 - Butt Weld Schedule 10, Stainless Steel BW4 - Butt Weld Schedule 40, Carbon Steel, Stainless Steel NP - No Pipe Ends	**
2"	E - No handle valve built for automation V - Vacuum Service Prep X - Oxygen Service Prep	59	4 - Carbon Steel 6 - 316 S.S.	6 - 316 S.S.	T - TFE R - Reinforced TFE P - Polyfill	T - TFE Z - Graphite (2" only)	SE - Screw End SW - Socket Weld BW1 - Butt Weld, S.S. BW4 - Butt Weld, C.S., S.S. (2" only) NP - No Pipe Ends	**

** Variations (V-numbered options) Leave blank if no variations. See page 2 for listing.

* Ordering example depicts 1 1/2" Series 59 with 316 stainless steel body, pipe ends, ball and stem, reinforced TFE seats, TFE body seals, and socket weld ends.

†† To order a Series 59 Valve for use with: 34 or 36 actuators, use prefix ordering code "A". Example: 1" A 5946 PMSE. 39 or 75 actuators, use prefix ordering code "B".

Caution: Ball valves can retain pressurized media in the body cavity when closed. Use care when disassembling. Always open valve to relieve pressure prior to disassembly. Due to continuous development of our product range, we reserve the right to alter the dimensions and information contained in this brochure as required.

Flowserve Corporation has established industry leadership in the design and manufacture of its products. When properly selected, this Flowserve product is designed to perform its intended function safely during its useful life. However, the purchaser or user of Flowserve products should be aware that Flowserve products might be used in numerous applications under a wide variety of industrial service conditions. Although Flowserve can (and often does) provide general guidelines, it cannot provide specific data and warnings for all possible applications. The purchaser/user must therefore assume the ultimate responsibility for the proper sizing and selection, installation, operation, and maintenance of Flowserve products. The purchaser/user should read and understand the Installation Operation Maintenance (IOM) instructions included with the product, and train its employees and contractors in the safe use of Flowserve products in connection with the specific application.

While the information and specifications contained in this literature are believed to be accurate, they are supplied for informative purposes only and should not be considered certified or as a guarantee of satisfactory results by reliance thereon. Nothing contained herein is to be construed as a warranty or guarantee, express or implied, regarding any matter with respect to this product. Because Flowserve is continually improving and upgrading its product design, the specifications, dimensions and information contained herein are subject to change without notice. Should any question arise concerning these provisions, the purchaser/user should contact Flowserve Corporation at any one of its worldwide operations or offices.

For more information about Flowserve Corporation, visit www.flowserve.com or call USA 1 800 225 6989.

FLOWERVE CORPORATION
FLOW CONTROL DIVISION
1978 Foreman Drive
Cookeville, Tennessee 38501 USA
Phone: 931 432 4021
Facsimile: 931 432 3105
www.flowserve.com