

Triac "V" Series Ball Valves are ideal for achieving more precise control with the simplicity and sealing features of a ball valve. We offer them 1/2" – 4" in a 3-piece design and 1/2" – 6" flanged. The standard "V" notch options are 30°, 60° & 90°. While they are available as manual valves, we specialize in automating them to suit your particular control requirements.

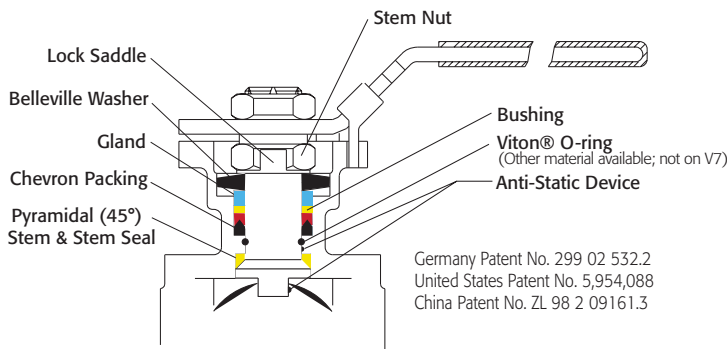

Easy to Automate!

See automated data sheets for pre-sized assemblies



Pneumatic



Electric



"V" Series Control Port Ball Valves

Sizes 1/2"-4", 3-Piece (V7, V8)

Sizes 1/2"-6", 150# Flanged (V9)

Sizes 1/2"-6", 300# Flanged (FVD9)

316SST or WCB

30°, 60° & 90° "V" Notch Standard
 Others on Request



HOW TO ORDER MANUAL VALVES

SAMPLE PART #

V8C-TH-0200-XXX

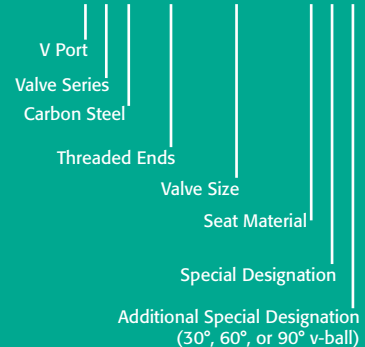

See part number matrix for itemized options

"V" SERIES Control Port Ball Valves



9955 International Blvd.
 Cincinnati, Ohio 45246
 www.atcontrols.com

PHONE (513) 247-5465
 FAX (513) 247-5462
 sales@atcontrols.com

V7 3-Piece Flow Coefficients - Cv Chart

Valve Size	Ball Angle	0%	15%	20%	30%	40%	50%	60%	70%	80%	90%	100%
1/2"	30	0.0	0.0	0.0	0.0	0.0	0.0	0.1	0.3	0.5	0.9	1.5
	60	0.0	0.0	0.0	0.0	0.0	0.0	0.1	0.3	0.8	1.7	3.2
	90	0.0	0.0	0.0	0.0	0.0	0.0	0.2	0.5	1.2	2.5	4.6
3/4"	30	0.0	0.0	0.0	0.0	0.1	0.4	0.7	1.3	2.0	3.0	4.4
	60	0.0	0.0	0.0	0.0	0.1	0.5	1.1	2.0	3.4	5.7	9.5
	90	0.0	0.0	0.0	0.0	0.2	0.6	1.4	2.8	5.0	9.0	15.3
1"	30	0.0	0.0	0.0	0.2	0.6	1.2	2.0	3.1	4.5	6.5	8.3
	60	0.0	0.0	0.0	0.2	0.8	1.6	3.0	5.0	8.0	12.3	19.7
	90	0.0	0.0	0.0	0.2	0.9	2.1	3.9	7.0	11.9	19.6	31.1
1-1/2"	30	0.0	0.0	0.0	0.8	2.3	4.2	6.7	9.8	14.4	20.3	29.5
	60	0.0	0.0	0.0	0.9	2.6	4.9	8.3	13.6	22.4	34.2	50.0
	90	0.0	0.0	0.0	0.9	2.9	6.0	10.5	18.0	31.2	50.4	73.0
2"	30	0.0	0.0	0.7	2.8	5.7	9.1	13.8	20.3	28.4	38.6	54.2
	60	0.0	0.0	0.7	3.0	6.4	11.0	17.5	28.2	43.9	65.4	104.6
	90	0.0	0.0	0.7	3.4	7.4	13.4	22.9	38.4	62.3	98.2	157.0
2 1/2"	30	0.0	0.0	0.1	2.6	6.5	11.7	18.4	27.9	39.6	54.3	60.0
	60	0.0	0.0	0.1	2.8	7.7	14.6	24.5	40.7	64.0	97.1	139.0
	90	0.0	0.0	0.2	3.3	9.1	18.0	32.3	55.4	92.4	149.9	265.0
3"	30	0.0	0.0	0.7	3.9	8.6	15.4	24.3	36.3	50.7	70.0	96.8
	60	0.0	0.0	0.7	4.6	11.3	21.1	35.0	56.4	89.4	134.2	207.1
	90	0.0	0.0	0.8	5.7	14.4	27.7	48.1	82.5	136.1	214.7	363.6
4	30	0.0	0.0	4.3	11.3	20.9	34.9	50.2	72.9	98.6	129.6	177.1
	60	0.0	0.0	4.9	14.0	27.2	46.3	73.2	112.1	170.5	251.0	375.3
	90	0.0	0.0	5.7	17.4	35.1	62.1	101.1	164.2	255.8	399.9	610.0
FL		0	0.96	0.95	0.94	0.93	0.92	0.9	0.88	0.86	0.82	0.75
Xt		0	0.98	0.77	0.71	0.67	0.64	0.63	0.62	0.55	0.43	0.4

VALVE STANDARDS

V7 3-Piece	
Design	ANSI/ASME B16.34
End Connections	ANSI/ASME BPE-1997/2000
Pressure Testing	API 598
Mounting	ISO 5211
Marking System for Valves	MSS SP-25, ISO 5209
CE Approval	PED 97/23/EC Module H
Safety Integrity	IEC 61508:2010; SIL 3
Material Certification	EN 10204-3.1 MTR
Quality Assurance	ISO 9001:2008

V8 3-Piece & V9 Flanged Flow Coefficients - Cv Chart

Valve Size	Ball Angle	0%	15%	20%	30%	40%	50%	60%	70%	80%	90%	100%
1/2"	30	0.0	0.1	0.1	0.2	0.3	0.5	0.8	1.1	1.6	2.2	2.6
	60	0.0	0.1	0.1	0.3	0.5	0.9	1.4	2	3.3	4.4	6
	90	0.0	0.1	0.2	0.4	0.6	0.9	1.5	2.2	3.8	5.4	6.9
3/4"	30	0.0	0.1	0.2	0.5	0.7	1.1	1.8	2.4	3.3	4.5	5.4
	60	0.0	0.1	0.2	0.7	1	1.7	2.8	4	6.5	9	12
	90	0.0	0.2	0.4	0.8	1.2	2	3.1	4.6	8	11.3	14
1"	30	0.0	0.1	0.3	0.8	1.3	2.3	3.5	5.1	8.5	9.8	10
	60	0.0	0.2	0.4	1.1	1.8	3.4	5.3	7.9	12.3	15.3	21
	90	0.0	0.2	0.6	1.8	3.4	5.1	8.1	11.4	16	21	29
1-1/4"	30	0.0	0.2	0.4	1.1	2	3.7	5.5	8	10	13	15
	60	0.0	0.2	0.6	1.8	3	5.5	9.5	12.8	19	26	39
	90	0.0	0.3	0.8	2	5	8	14	19	28	39	55
1-1/2"	30	0.0	0.3	0.6	1.6	3	5	7.5	11	14	17	20
	60	0.0	0.4	0.8	2.5	4	8	13	19	27	40	52
	90	0.0	0.4	0.9	3.5	7	13	20	31	42	63	78
2"	30	0.0	0.4	1.2	3.8	6	10	15	23	31	43	60
	60	0.0	0.4	1.5	4.6	9	16.5	27	39	55	83	110
	90	0.0	0.5	2	6	12	22	35	45	70	105	135
2-1/2"	30	0.0	0.4	1	4	8	12	18	28	37	62	75
	60	0.0	0.4	1.5	5	10	21	34	53	75	103	150
	90	0.0	0.5	1.7	7	14	28	48	70	106	160	218
3"	30	0.0	0.5	1.2	4	8	14	23	33	46	65	82
	60	0.0	0.5	2.5	6	14	25	40	65	91	128	165
	90	0.0	0.7	3.5	8	18	35	60	90	135	205	310
4"	30	0.0	0.6	2	6	15	29	48	71	100	130	159
	60	0.0	0.7	3	11	25	40	59	90	141	212	356
	90	0.0	1	3.5	16	40	75	125	190	265	442	670
6"	30	0.0	0.9	3.2	14	33	60	103	155	220	280	350
	60	0.0	2	5	22	60	110	190	285	416	586	800
	90	0.0	3	8	35	90	160	280	425	650	970	1,480
FL		0	0.96	0.95	0.94	0.93	0.92	0.9	0.88	0.86	0.82	0.75
Xt		0	0.98	0.77	0.71	0.67	0.64	0.63	0.62	0.55	0.43	0.4

VALVE STANDARDS

V8 3-Piece	
Design	ANSI/ASME B16.34
End Connections	ASME B16.25, B1.20.1, B16.11
Pressure Testing	API 598
Mounting	ISO 5211
Marking System for Valves	MSS SP-25, ISO 5209
Safety Integrity	IEC 61508:2010; SIL 3
Material Certification	EN 10204-3.1 MTR
Quality Assurance	ISO 9001:2008

V9 Class 150 Flanged	
Design	ANSI/ASME B16.34
Face to Face	ANSI/ASME B16.10
Flange Dimensions	ANSI/ASME B16.5
Pipeline Valves	API 6D
Pressure Testing	API 598
Mounting	ISO 5211
Marking System for Valves	MSS SP-25
Safety Integrity	IEC 61508:2010; SIL 3
Material Certification	EN 10204-3.1 MTR
Quality Assurance	ISO 9001:2008

FVD9 Class 300 Flanged

Design	ANSI/ASME B16.34
Face to Face	ANSI/ASME B16.10
Flange Dimensions	ANSI/ASME B16.5
Pipeline Valves	API 6D
Pressure Testing	API 598
Fire Testing	API 607 6th Ed. on 1/2"-4" SST & WCB and 6" WCB; API-607 4th Ed. on 6" SST
Sulfide Stress Protection	NACE MR0175
Coast Guard Approved	Category A: 46 CFR 56.20-15(b)(2)
Safety Integrity	IEC 61508:2010; SIL 3
Mounting	ISO 5211
Marking System for Valves	MSS SP-25
Material Certification	EN 10204-3.1 MTR
Quality Assurance	ISO 9001:2008

"V" Series

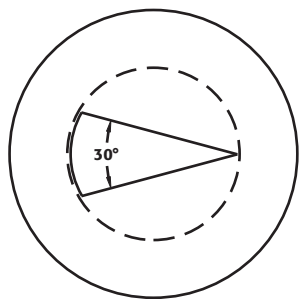

30° V-Port

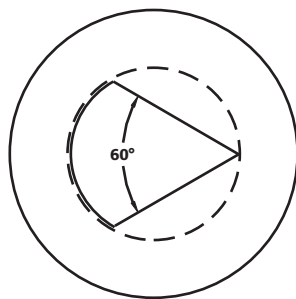

60° V-Port

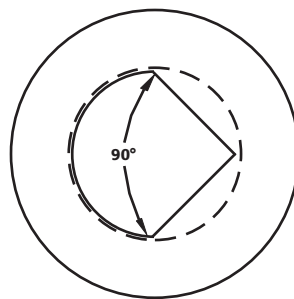

90° V-Port

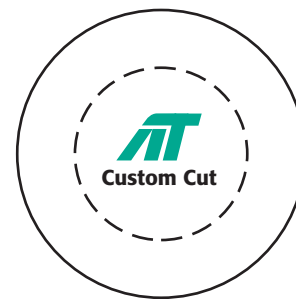

Note: May be customized; call factory for flow analysis design.

Triac "V" port control valves are available with 30°, 60°, & 90° V-notch options. V-port valves offer better and more consistent control than traditional round ported ball valves. We offer this valve with the control port cast and machined into the ball, not in the seat. This allows for much better flow characteristics and eliminates the need to replace seats. The 30° option allows for finer tapered control throughout the valve rotation, and the 60° & 90° offer a larger Cv in addition to controlled flow.

The PTFE seat is standard in the V7 valves, while the 50/50 STFE seat is standard with V8, V9, and FVD9 V-port valves. The 50% SST powder and 50% PTFE offers both strength and superior sealing properties.



- 3-Piece
- Sanitary End Ball Valve
- Tube Pipe Design

- With or without cavity filler
- 240 Grit Internal Polish
- Standard (15-20 RA)

V7 Series 3-Piece V-Port Control Valve

Pressure vs. Temperature Chart for PTFE Seats

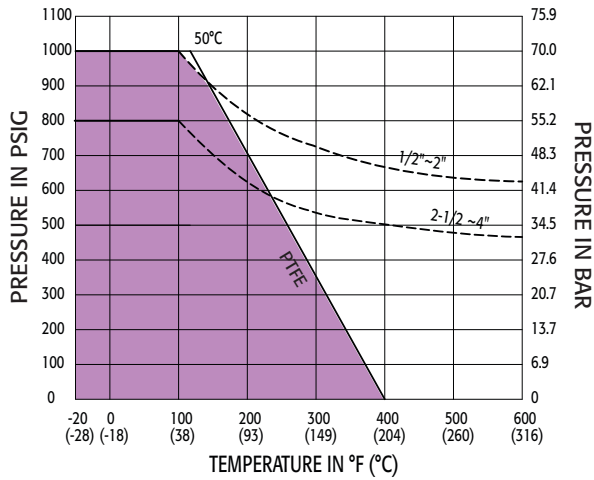

Breakaway Torques for PTFE		
Size	Non-Cavity Filled	Cavity Filled
1/2"	80	95
3/4"	90	100
1"	142	160
1-1/2"	319	410
2"	390	490
2-1/2"	806	1,010
3"	921	1,075
4"	1,317	1,400

CONSULT FACTORY FOR OTHER SEAT MATERIALS

MATERIALS LIST

NO.	PART NAME	QTY.	MATERIAL
1	BODY	1	ASTM A351 GRADE CF3M
2	END CAP	2	ASTM A351 GRADE CF3M
3	BALL	1	ASTM A276 GRADE CF3M
4	SEAT	2	PTFE
5	JOINT GASKET	2	PTFE
6	STEM SEAL	1	PTFE
7	STEM	1	ASTM A276 SS 316L
8	GLAND PACKING	1	PTFE
9	GLAND WASHER	1	RTFE
10	GLAND BUSHING	1	AISI 304
11	BELLEVILLE WASHER	2	AISI 301
12	LOCK SADDLE	1	AISI 304
13	STEM NUT	2	AISI 304
14	STEM WASHER	1	AISI 304
15	HANDLE	1	AISI 304
16	HANDLE LOCK	1	AISI 304
17	HANDLE SLEEVE	1	VINYL
18	BODY BOLT	#	**
19	BODY BOLT NUT	&	##
20	WASHER	&	AISI 304
21	STOP BOLT	1	AISI 304
22	BOLT NUT	1	AISI 304
23	ANTI-STATIC DEVICE	2	AISI 316

FOR 1/2"-3" - 4 PCS ; FOR 4" - 6 PCS
 & FOR 1/2"-2" - 4 PCS ; FOR 2-1/2"-3" - 8 PCS; FOR 4" - 12 PCS
 **FOR 1/2"-2" - ASTM A193 GRADE B8; FOR 2-1/2"-4" - ISO 3506-1 A2-70
 ## FOR 1/2"-2" - ASTM A194 GRADE 8; FOR 2-1/2"-4" - ISO 3506-2 A2-70

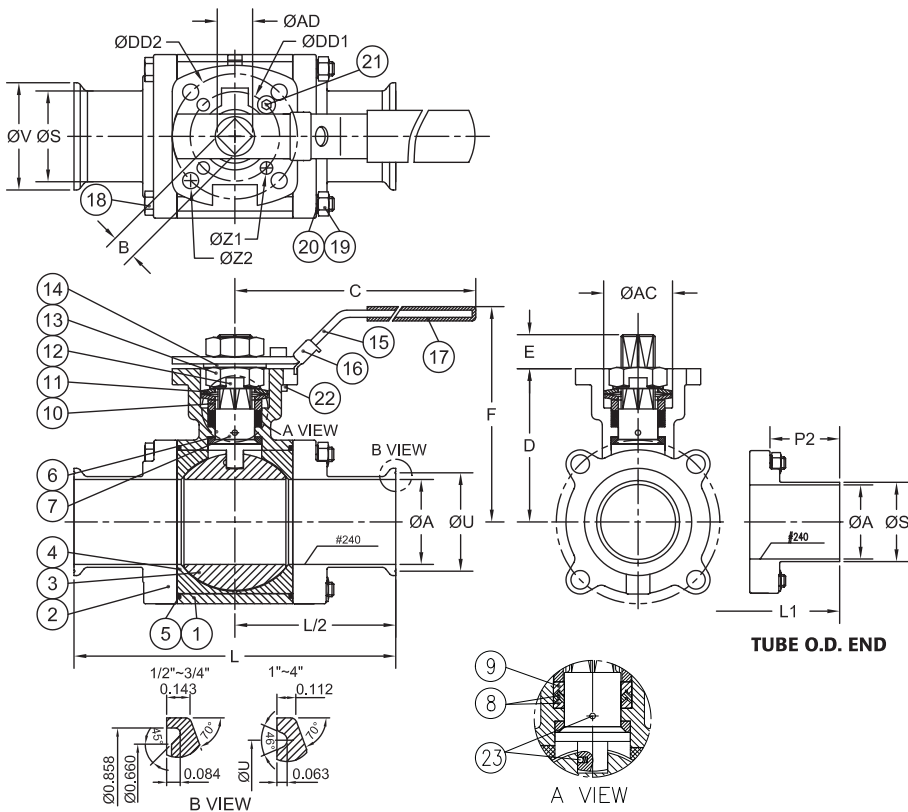

DIMENSIONS (IN)

Tube O.D. according to ASME BPE 1997/2000

SIZE	A	B	C	D	DD1	DD2	E	F	L	L1	P2	S	U	V	Z1	Z2	AC	AD	(LBS)	ISO 5211
1/2"	0.37	0.354	5.47	1.66	1.417	1.654	0.25	3.03	3.51	5.50	1.92	0.50	-	0.99	0.24	0.24	0.92	0.430	1.5	F03/F04
3/4"	0.62	0.354	5.47	1.89	1.417	1.654	0.27	3.27	4.00	5.75	1.96	0.75	-	0.99	0.24	0.24	0.92	0.430	1.8	F03/F04
1"	0.87	0.433	6.50	2.23	1.654	1.969	0.44	3.74	4.51	6.25	2.00	1.00	1.71	1.99	0.24	0.28	1.14	0.563	2.7	F04/F05
1-1/2"	1.37	0.551	8.47	3.05	1.969	2.756	0.56	5.00	5.52	7.50	2.23	1.50	1.71	1.99	0.28	0.34	1.54	0.744	7.0	F05/F07
2"	1.87	0.551	8.47	3.35	1.969	2.756	0.56	5.28	6.26	8.50	2.46	2.00	2.20	2.52	0.28	0.34	1.54	0.744	9.8	F05/F07
2-1/2"	2.37	0.669	11.81	4.28	2.756	4.016	0.67	6.54	6.85	9.75	2.55	2.50	2.78	3.05	0.34	0.47	2.07	0.885	19.6	F07/F10
3"	2.87	0.669	14.57	4.63	2.756	4.016	0.71	6.93	7.61	10.50	2.69	3.00	3.28	3.58	0.34	0.47	2.07	0.885	25.9	F07/F10
4"	3.83	0.748	14.57	5.22	2.756	4.016	0.67	7.48	8.90	12.50	3.14	4.00	4.34	4.68	0.34	0.47	2.07	0.885	47.4	F07/F10

V8 Series 3-Piece V-Port Control Valve

V8 Torque Values for 50/50 STFE Seats

Pressure vs. Temperature Chart
for Valves 1/4" to 4"

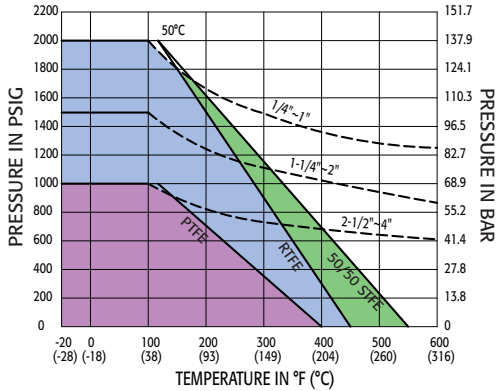

NOTE: Dotted line shows the rating for valve body. Solid line shows the rating for valve seat. Both ratings need to be considered when determining the limitation of the valve for specific application. Consult factory for other seat materials

Size	Torque (In-lbs)
1/2"	90
3/4"	120
1"	175
1-1/4"	265
1-1/2"	380
2"	520
2-1/2"	850
3"	1,300
4"	1,800

NOTE: 30% SAFETY FOR LUBRICATING SERVICE @ 285 PSID

MATERIALS LIST

NO.	PART NAME	QTY	STAINLESS STEEL	CARBON STEEL
1	BODY	1	ASTM A351 GRADE CF8M	ASTM A216 GRADE WCB
2	TH END CAP	2	ASTM A351 GRADE CF8M	ASTM A216 GRADE WCB
2	BW/SW END CAP	2	ASTM A351 GRADE CF3M	ASTM A216 GRADE WCB
3	BALL	1	1/4" THRU 3/8" ASTM A276 SS316	1/4" THRU 3/8" ASTM A276 SS316
3	BALL	1	1/2" THRU 4" ASTM A351 GRADE CF8M	1/2" THRU 4" ASTM A351 GRADE CF8M
4	SEAT	2	50/50 STFE	50/50 STFE
5	JOINT GASKET	2	PTFE	PTFE
6	STEM SEAL	1	RTFE	RTFE
7	STEM	1	ASTM A276 SS316	ASTM A276 SS316
8	GLAND PACKING	1 [^]	PTFE	PTFE
9	GLAND BUSHING	1	AISI 304	AISI 304
10	LOCK SADDLE	1	AISI 304	AISI 304
11	STEM NUT	1	AISI 304	AISI 304
12	HANDLE	1	AISI 304	AISI 304
13	HANDLE SLEEVE	1	VINYL	VINYL
14	STEM WASHER	1	AISI 304	AISI 304
15	BODY BOLT/STUD	*	ASTM A193 GRADE B8	ASTM A193 GRADE B8
16	BODY NUT	#	ASTM A194 GRADE 8	ASTM A194 GRADE 8
17	BELLEVILLE WASHER	2	AISI 301	AISI 301
18	STOP BOLT	1	AISI 304	AISI 304
19	STOP BOLT NUT	1	AISI 304	AISI 304
20	GLAND WASHER	1	RTFE	RTFE
21	HANDLE LOCK	1	AISI 304	AISI 304
22	ANTI-STATIC DEVICE	2	AISI 316	AISI 316
23	STEM O-RING	1	VITON®	VITON®

[^] PACKING SET
* 1/4" THRU 1-1/2" QTY = 4 PCS
* 2" THRU 4" QTY = 6 PCS
1/4" THRU 1-1/2" QTY = 4 PCS
2" THRU 4" QTY = 12 PCS

NOTE: SIZES 2-1/2" THRU 4" INCLUDE SEAT RETAINER RINGS.

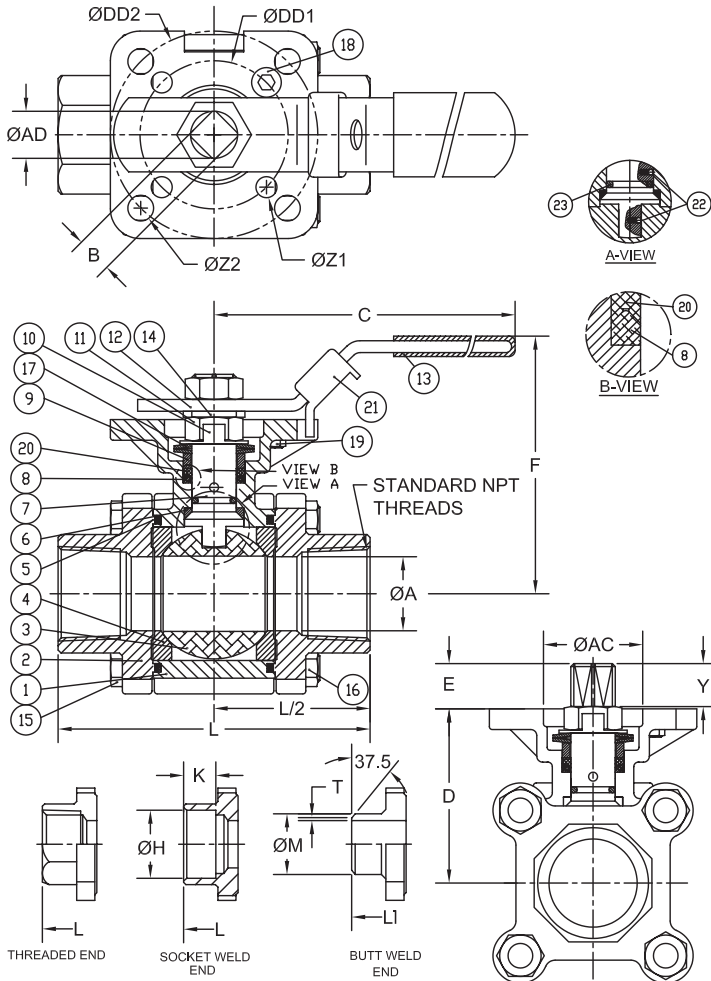

DIMENSIONS (IN)

SIZE	øA	B	C	D	E	F	H	K	L	L1	M	T	Y	AC	AD	DD1	DD2	øZ2	øZ1	(LBS)	ISO 5211
1/4"	0.45	0.354	5.47	1.66	0.25	3.00	0.55	0.39	2.95	2.95	0.85	0.13	0.25	1.04	0.44	1.654	1.969	0.28	0.28	1.6	F04/F05
3/8"	0.50	0.354	5.47	1.66	0.25	3.00	0.69	0.39	2.95	2.95	0.85	0.11	0.25	1.04	0.44	1.654	1.969	0.28	0.28	1.6	F04/F05
1/2"	0.59	0.354	5.47	1.66	0.25	3.00	0.85	0.39	2.85	2.95	0.85	0.06	0.25	1.07	0.44	1.654	1.969	0.28	0.28	2.0	F04/F05
3/4"	0.79	0.354	5.47	1.83	0.33	3.20	1.07	0.51	3.36	3.54	1.07	0.06	0.33	1.07	0.44	1.969	2.756	0.34	0.28	3.0	F05/F07
1"	0.98	0.433	6.50	2.31	0.41	3.86	1.34	0.51	4.15	4.33	1.34	0.06	0.41	1.34	0.56	1.969	2.756	0.34	0.28	4.5	F05/F07
1-1/4"	1.26	0.433	6.50	2.46	0.41	4.00	1.69	0.51	4.37	4.53	1.68	0.06	0.41	1.34	0.56	1.969	2.756	0.34	0.28	6.0	F05/F07
1-1/2"	1.50	0.551	8.46	3.11	0.53	5.04	1.92	0.51	5.01	5.12	1.91	0.06	0.53	1.54	0.74	1.969	2.756	0.34	0.28	10.0	F05/F07
2"	1.97	0.551	8.46	3.42	0.53	5.35	2.40	0.63	5.62	5.62	2.38	0.06	0.53	1.54	0.74	1.969	2.756	0.35	0.30	13.0	F05/F07
2-1/2"	2.56	0.748	10.31	4.28	0.66	6.60	2.89	0.63	7.28	7.28	3.00	N/A	0.66	2.09	0.94	2.756	4.016	0.47	0.39	26.0	F07/F10
3"	3.15	0.748	10.31	4.63	0.70	6.96	3.54	0.63	8.07	8.07	3.54	N/A	0.70	2.09	0.94	2.756	4.016	0.47	0.39	34.0	F07/F10
4"	3.94	0.748	12.28	5.26	0.66	7.59	4.54	0.79	9.45	9.45	4.57	N/A	0.66	2.09	0.94	2.756	4.016	0.47	0.39	52.0	F07/F10

V9 Series ANSI Class 150 Flanged V-Port Control Valve

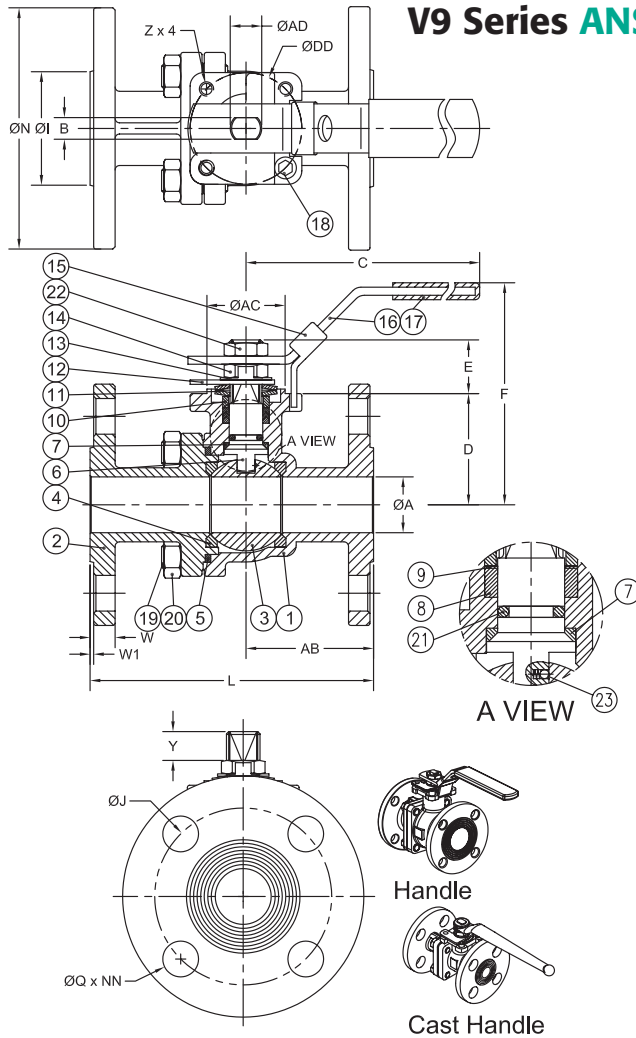

MATERIALS LIST

NO.	PART NAME	QTY	STAINLESS STEEL	CARBON STEEL
1	BODY	1	ASTM A351 GRADE CF8M	ASTM A216 GRADE WCB
2	END CAP	1	ASTM A351 GRADE CF8M	ASTM A216 GRADE WCB
3	BALL	1	ASTM A351 GRADE CF8M	ASTM A351 GRADE CF8M
4	SEAT	2	50/50 STFE	50/50 STFE
5	JOINT GASKET	1	PTFE	PTFE
6	STEM	1	ASTM A276 SS316	ASTM A276 SS316
7	STEM SEAL	1	RTFE	RTFE
8	GLAND PACKING	1 [^]	PTFE	PTFE
9	GLAND WASHER	1	RTFE	RTFE
10	GLAND BUSHING	1	AISI 304	AISI 304
11	BELLEVILLE WASHER	2	AISI 301	AISI 301
12	LOCKING PLATE	1	AISI 304	AISI 304
13	LOCK SADDLE	1	AISI 304	AISI 304
14	STEM NUT	1	AISI 304	AISI 304
15	HANDLE LOCK	1	AISI 304	AISI 304
16	HANDLE	1	AISI 304	AISI 304
17	HANDLE SLEEVE	1	VINYL	VINYL
18	STOP BOLT	1	AISI 304	AISI 304
19	BODY BOLT	*	ASTM A193 GRADE B8	# ASTM A193 GRADE B8
20	BODY NUT	*	ASTM A194 GRADE 8	## ASTM A194 GRADE 8
21	O-RING	1	VITON®	VITON®
22	HANDLE NUT	1	AISI 304	AISI 304
23	ANTI-STATIC DEVICE	2	AISI 316	AISI 316

[^] PACKING SET
 * 1/2" THRU 2" QTY = 4 PCS
 * 2-1/2" THRU 6" QTY = 8 PCS
 # ASTM A193 GRADE B7 FOR 6"
 ## ASTM A194 GRADE 2H FOR 6"

V9 Flanged Torque Values for 50/50 STFE Seats

Size	Torque (In-lbs)
1/2"	104
3/4"	160
1"	210
1-1/2"	420
2"	580
2-1/2"	875
3"	1,400
4"	2,150
6"	4,500

NOTE: 30% SAFETY FOR LUBRICATING SERVICE @ 285 PSID

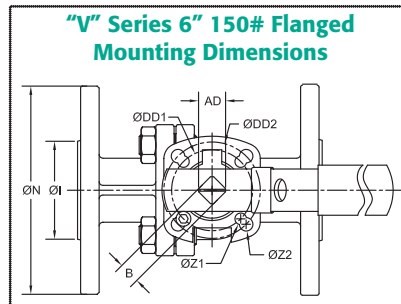

Pressure vs. Temperature Chart for Valves 1/2" to 6"

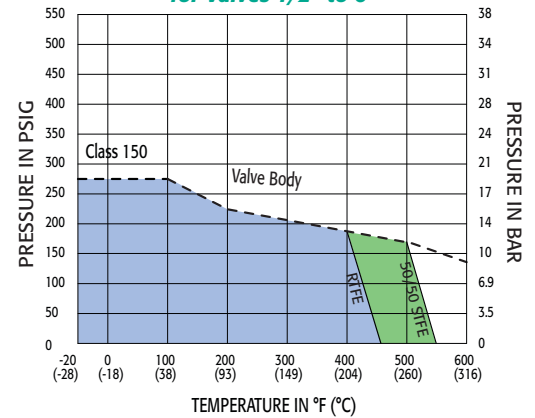

NOTE: Dotted line shows the rating for valve body. Solid line shows the rating for valve seat. Both ratings need to be considered when determining the limitation of the valve for specific application. Consult factory for other seat materials.

DIMENSIONS (IN)

SIZE	A	B	C	D	E	F	I	J	L	N	Q	W	W1	Y	Z	AB	AC	AD	DD	NN (LBS)	ISO 5211		
1/2"	0.59	0.315	6.69	1.34	0.92	3.15	1.47	2.38	4.26	3.50	0.63	0.44	0.06	0.36	M5	1.82	1.17	0.43	1.654	4	3.7	F04	
3/4"	0.79	0.315	6.69	1.65	0.94	3.43	1.82	2.75	4.62	3.88	0.63	0.44	0.06	0.40	M5	2.17	1.17	0.43	1.654	4	4.6	F04	
1"	0.98	0.382	8.05	1.95	0.94	3.85	2.08	3.13	5.00	4.26	0.63	0.44	0.06	0.42	M6	2.20	1.37	0.56	1.969	4	6.8	F05	
1-1/2"	1.50	0.472	10.28	3.08	1.37	6.02	2.88	3.88	6.50	5.00	0.63	0.56	0.06	0.58	M8	2.81	2.17	0.75	2.756	4	13.6	F07	
2"	1.97	0.472	10.28	3.40	1.37	6.38	3.62	4.75	7.02	6.00	0.75	0.63	0.06	0.58	M8	3.38	2.17	0.75	2.756	4	19.2	F07	
2-1/2"	2.56	0.472	10.28	3.83	1.37	6.81	4.12	5.50	7.49	7.00	0.75	0.69	0.06	0.58	M8	3.02	2.17	0.75	2.756	4	30.0	F07	
3"	3.15	0.591	13.94	4.23	1.81	6.95	5.00	6.00	8.01	7.50	0.75	0.75	0.06	0.93	M10	4.01	2.76	0.94	4.016	4	41.0	F10	
4"	3.94	0.591	13.94	4.82	1.79	7.52	6.19	7.50	9.04	9.00	0.75	0.94	0.06	0.93	M10	4.06	2.76	0.94	4.016	8	65.0	F10	
SIZE	A	B	C	D	E	F	I	J	L	N	Q	W	W1	Z1	Z2	AB	AC	AD	DD1	DD2	NJN (LBS)	ISO 5211	
6"	5.91	1.063	29.53	8.28	1.12	12.50	8.50	9.50	15.50	11.00	0.87	1.00	0.06	0.55	0.71	7.00	2.97	1.41	4.921	5.511	8	145.0	F12/F14

FVD9 Series ANSI Class 300 Flanged V-Port Control Valve

Pressure vs. Temperature Chart
for Valves 1/2" to 6"

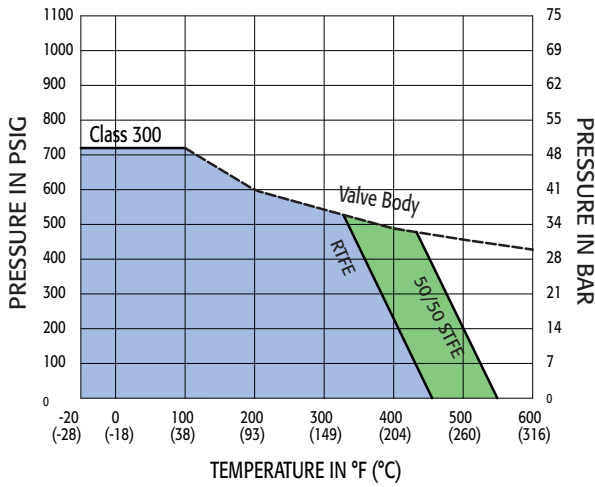

NOTE: Dotted line shows the rating for valve body. Solid line shows the rating for valve seat. Both ratings need to be considered when determining the limitation of the valve for specific application. Consult factory for other seat materials.

FVD9-F3 Torque Values
for 50/50 STFE Seats

Size	Torque (In-lbs) @ 285 PSID	Torque (In-lbs) @ 740 PSID
1/2"	120	150
3/4"	165	190
1"	200	250
1-1/2"	450	500
2"	600	850
2-1/2"	920	1,200
3"	1,600	1,900
4"	2,350	3,800
6"	4,700	7,000

NOTE: 30% SAFETY FOR LUBRICATING SERVICE @ 285 PSID

MATERIALS LIST

NO.	PART NAME	QTY	STAINLESS STEEL	CARBON STEEL
1	BODY	1	ASTM A351 GRADE CF8M	ASTM A216 GRADE WCB
2	END CAP	1	ASTM A351 GRADE CF8M	ASTM A216 GRADE WCB
3	BALL	1	ASTM A351 GRADE CF8M	ASTM A351 GRADE CF8M
4	SEAT	2	50/50 STFE	50/50 STFE
5	JOINT GASKET	1	GRAFOIL	GRAFOIL
6	STEM	1	ASTM A276 SS316	ASTM A276 SS316
7	STEM SEAL	1	RTFE	RTFE
8	GLAND PACKING	1	GRAFOIL	GRAFOIL
9	GLAND WASHER	1	RTFE	RTFE
10	GLAND BUSHING	1	AISI 304	AISI 304
11	BELLEVILLE WASHER	2	AISI 301	AISI 301
12	LOCK SADDLE	1	AISI 304	AISI 304
13	STEM NUT	1	AISI 304	AISI 304
14	STEM WASHER	1	AISI 304	AISI 304
15	HANDLE	1	AISI 304	AISI 304
16	HANDLE SLEEVE	1	VINYL	VINYL
17	BODY STUD	*	ASTM A193 GRADE B8M	ASTM A193 GRADE B7M
18	BODY NUT	*	ASTM A194 GRADE 8M	ASTM A194 GRADE 2HM
19	STOP BOLT	1	AISI 304	AISI 304
20	STOP BOLT NUT	1	AISI 304	AISI 304
21	HANDLE LOCK	1	AISI 304	AISI 304
22	O-RING	1	VITON®	VITON®
23	HANDLE NUT	1	AISI 304	AISI 304
24	ANTI-STATIC DEVICE	2	AISI 316	AISI 316

* 1/2" THRU 2" QTY = 4 PCS
* 2-1/2" THRU 4" QTY = 8 PCS
* 6" QTY = 12 PCS

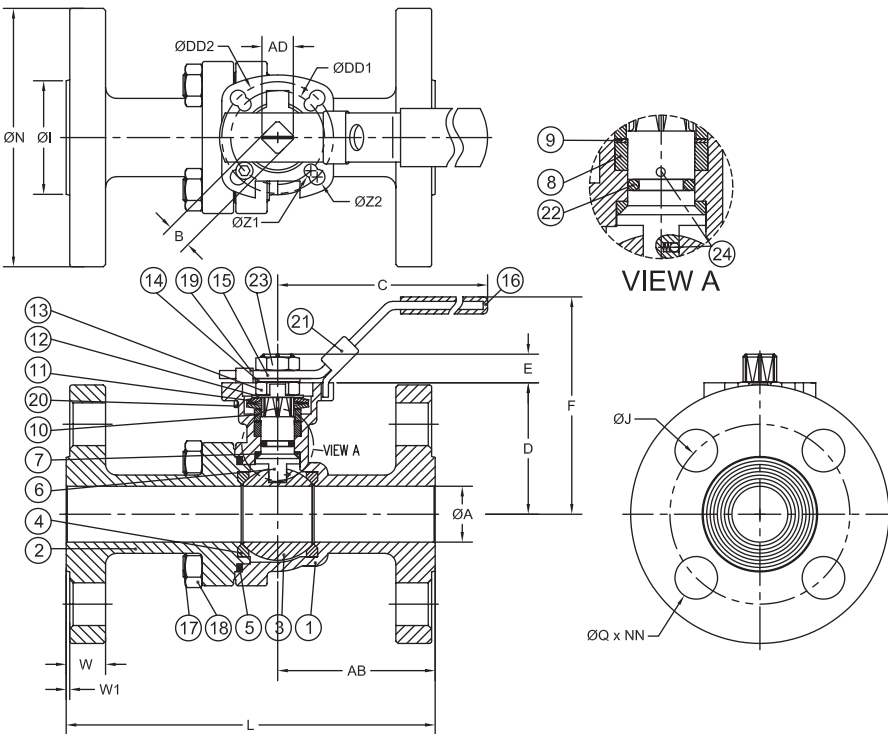

DIMENSIONS (IN)

SIZE	A	B	C	D	E	F	I	J	L	N	Q	W	W1	Z1	Z2	AB	AC	AD	DD1	DD2	NN	ISO 5211	LBS
1/2"	0.59	0.433	6.50	1.92	0.39	3.40	1.38	2.62	5.50	3.75	0.63	0.56	0.06	0.26	0.28	2.32	1.17	0.55	1.654	1.969	4	F04/F05	5
3/4"	0.79	0.433	6.50	2.50	0.41	4.04	1.69	3.25	6.00	4.62	0.75	0.62	0.06	0.26	0.28	2.59	1.17	0.55	1.654	1.969	4	F04/F05	8
1"	0.98	0.433	6.50	2.50	0.41	4.06	2.00	3.50	6.50	4.88	0.75	0.69	0.06	0.26	0.28	2.78	1.17	0.55	1.654	1.969	4	F04/F05	10.5
1-1/2"	1.50	0.748	10.32	3.51	0.75	5.41	2.88	4.50	7.50	6.12	0.87	0.81	0.06	0.39	0.47	3.13	2.08	0.94	2.756	4.016	4	F07/F10	22
2"	1.97	0.748	10.32	3.80	0.75	5.87	3.62	5.00	8.50	6.50	0.75	0.88	0.06	0.39	0.47	3.81	2.08	0.94	2.756	4.016	8	F07/F10	28.5
2-1/2"	2.56	0.748	10.32	4.57	0.75	6.44	4.12	5.88	9.50	7.50	0.87	1.00	0.06	0.39	0.47	4.20	2.08	0.94	2.756	4.016	8	F07/F10	42
3"	3.15	0.866	14.37	5.22	0.91	8.10	5.00	6.62	11.12	8.25	0.87	1.12	0.06	0.47	0.55	5.10	2.55	1.17	4.016	4.921	8	F10/F12	59
4"	3.94	0.866	14.37	6.18	0.91	8.70	6.19	7.88	12.00	10.00	0.87	1.25	0.06	0.47	0.55	5.50	2.55	1.17	4.016	4.921	8	F10/F12	96
6"	5.91	1.063	29.53	8.28	1.12	13.00	8.50	10.62	15.87	12.50	0.87	1.44	0.06	0.55	0.71	7.30	3.07	1.40	4.921	5.512	12	F12/F14	213