

TWIP[®] Level Switches

(Turbine Water Induction Protection)

Water Detection for Alarms, Trips, Drain Pot, Heaters, Deaerators, and Condensate Tank Applications



Reliance[®]

A PRODUCT OF CLARK-RELIANCE

TWIP® System

Simple • Versatile • Accurate • Reliable • Low Maintenance

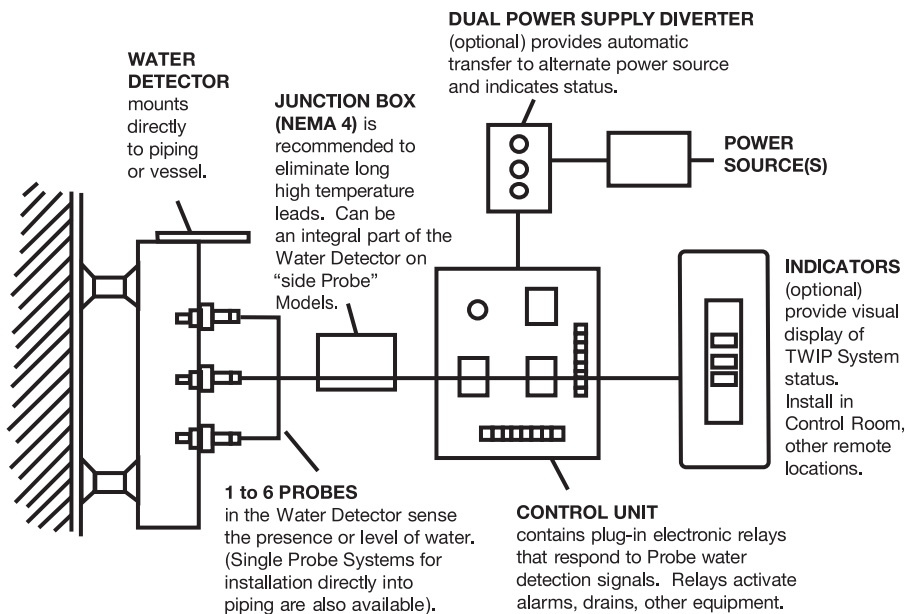

Typical Power Plant Installation Locations

Drain Pots • Deaerators • Flash Tanks • Feed Water Heaters • Boiler Drums • Water Columns • Storage Tanks • Blowdown Tanks • Separators • System Piping • Wherever Water Presence Must Be Known

TWIP® System Detection Protects Turbines from Catastrophic Damage Caused by Water Influx

The most effective protection against turbine water damage is a well designed steam plant. However, in the best of plants, the potential for disaster remains ever present. Industry research indicates a 35% probability of new equipment damage during the first five years of operation.

Abnormal conditions can arise quickly. Pump failures, valve failures, excessive condensation, site flooding and other events make every steam plant a possible candidate for swift and unexpected turbine damage.

Designing for Accuracy The ideal water detection device must fulfill multiple objectives. Foremost, false alarms are unacceptable. Equally undesired are the cost and nuisance of routine testing to assure proper equipment performance.

The TWIP® System attacks these detection problems directly and effectively. TWIP® combines industry's most successful sensing Probes with a choice of versatile, high technology equipment options. TWIP® Systems of proven reliability and accuracy are easily tailored for strategic location within any individual steam plant.

As an option, two trip probes can be installed vertically in the Water Detector at the same level (trip point), to assure that even with voting logic circuitry, the trip point is always at the same single level.

The utmost in performance is achieved in TWIP® Systems using the optional "Voting Logic" trip circuit – employing a circuit logic in which any 2 or 3 designated probes will activate the trip circuit when water is present. Voting Logic virtually eliminates false trips caused by malfunctioning trip probes – or a single level control failure.

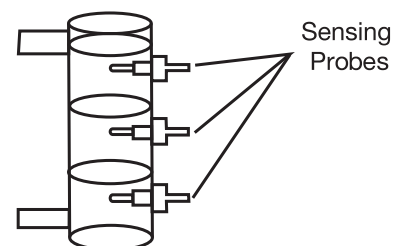

The Water Detector

Where the TWIP® System's liquid connections end
– and advanced electronic operation begins.

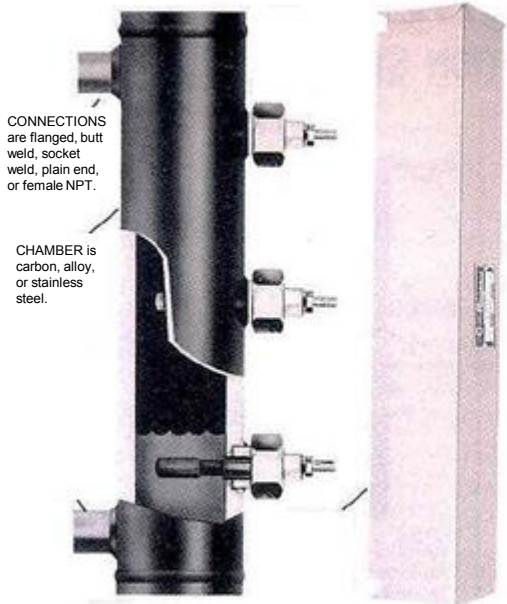

CONNECTIONS are flanged, butt weld, socket weld, plain end, or female NPT.

CHAMBER is carbon, alloy, or stainless steel.

Water Detector attaches to plant equipment, contains 1 to 6 Sensing Probes

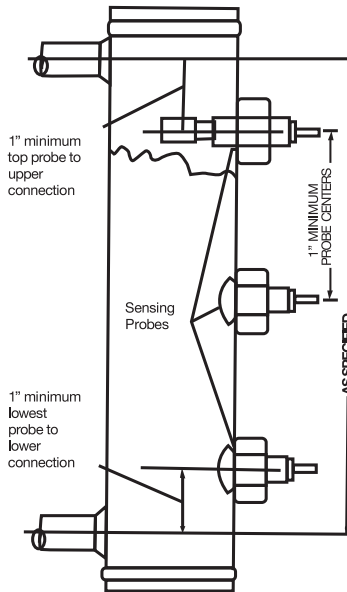

Typical arrangement and dimensions for 3-Probe Water Detector

The Water Detector is attached to steam plant equipment or piping.

To facilitate installation, connections may be of the size, type and orientation best suited to each application. The Water Detector is available in various materials to withstand system pressures to 3000 PSI (206 Bar) or temperatures to 1100°F (593°C).

One or more sensing Probes are located at various chamber levels to signal the arrival or level of water within. Probes may be installed at whatever chamber locations are desired.

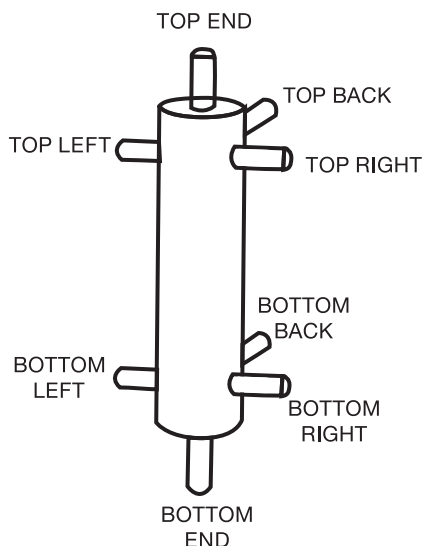

WATER DETECTOR CONNECTION OPTIONS

Choose any combination of two Water Detector connection locations shown below. Flanged, welded, or screwed.

Optional FLEXPAK® Jacket

For maximum system accuracy and personnel safety, the Water Detector should be insulated with the optional FLEXPAK® jacket. The jacket provides a 2 inch thick insulation that is easily removed for routine equipment inspections. The jacket is suitable for outdoor service.



Jacket Improves TWIP® Performance

Traditional & Brazed Probes

TWIP System Probes are manufactured from premium materials throughout

Traditional Probes



Brazed Probes



The **T Type** has been designed for pressures up to 450 PSI (30 Bar).
The **V Type** has been designed for pressures up to 1000 PSI (66 Bar).
("T" and "V" probes are Teflon insulated with an average service life of 5 to 15 years).

The **ZB Type** brazed probe has been designed for pressures up to 1800 PSI (120 Bar).

The **FB type** brazed probe has been designed for pressures up to 3000 PSI (200 Bar).

The **FSB Type** has been designed for pressures up to 3000 PSI (200 Bar).

These probes provide maximum service life on applications with frequent cycling, with an average service life of 5 years. Non-brazed type probes ZG rated to 1800 PSI (120 Bar) and FG rated to 3000 PSI (200 Bar) remain available for traditional applications.



No gaskets means low risk for leakage in especially high pressure and frequent cycling applications. The FSB brazed probe has proven to be successful in many extremely harsh applications with an average service life 5 years.

The performance reliability of the TWIP® System is related directly to the exceptional success of Clark-Reliance Probes. Clark-Reliance pioneered Probe technology and now continues to lead in the innovative design and precision manufacture of water detecting Probes.

Located in the Water Detector, the sensing Probes complete an electrical circuit when water reaches the Probe tip. The completed circuit signals a relay in the Control Unit which, in turn, can activate an alarm, drain, pump, or other equipment.

Clark-Reliance Probes allow even pure water of ultra-low conductivity (less than 1 micro mho) to complete electrical circuits.

Clark-Reliance offers a full selection of conductivity probes to meet your specifications. Originally introduced in 1959, our conductivity probe technology has since become the most relied-upon for boiler drum level applications.

TWIP® System

Model Numbering Code

Below is an example of a typical model number which accurately designates a specific Clark-Reliance TWIP® System. Use this Model Numbering Code to determine the proper Model Number for your system and application requirements. Consult factory for NDE requirements on applications over 750°F (400°C).

TWIP® Model Numbering Code

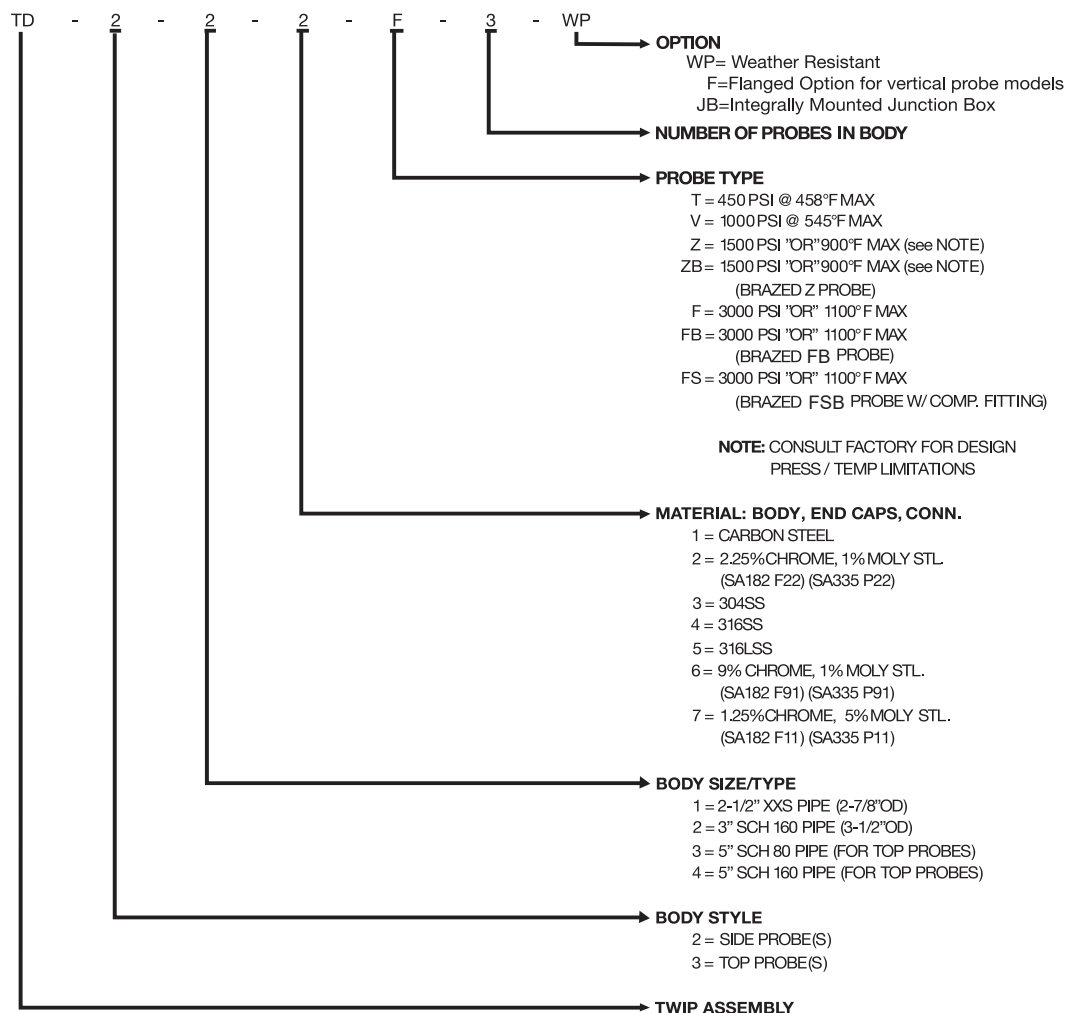

TWIP® System General Specifications

- TWIP® Systems include the Water Detector, Water Detector Housing, Probe(s), and Control Unit
- Options include the TWIP® Indicators, Dual Power Supply Diverter, FLEXPAK Jacket, choice of NEMA Control Unit Enclosure, Integral Junction Box, plus electrical specifications as required.
- Water Detectors and Probes are available for pressures to 3000 PSI (206 Bar) or temperatures to 1100°F (593°C). Water Detectors comply with ANSI B31.1 on request.
- Each Probe comes with a 30" high temperature lead. Use of 18 AWG insulated wire is recommended for TWIP® System on-site wiring to the relay control.
- Relays are furnished for line voltage and frequency as specified. Switch contacts are UL rated at 5A/115 VAC, 8A/230 VAC, and 1A/125 VDC.

Control Unit

Contains plug-in electronic relays which respond to probe contact with water, automatically activating alarms or controls.



TWIP® Control Units, employing plug-in relays, printed circuit boards and other advanced componentry, are lightweight, compact and easily installed. Control Units may be located up to 1000 feet from the Water Detector. In “direct mode” operation, water that contacts any sensing Probe immediately completes an electrical circuit to the Probe’s corresponding relay in the Control Unit. The relay activates auxiliary functions such as indicators, solenoid valves, drain valves, audio/visual alarms, or other protective devices programmed to counteract or respond to the detection of unwanted water. Relays may also work in an “inverse” mode, providing deactivation of electrical controls to prevent false signals during a power outage. When water drops below the sensing Probe, the corresponding relay will revert to its prior state. Relays supply 12 VAC to Probes and require 115 VAC or 230 VAC 50/60 Hz line supply. Time delay is available upon request. Each control relay contains an LED to verify operational status.

TWIP® Control Units				
Model Number	Relays	Enclosures	Indicator Circuit	Functions
R110L	1	Nema1	No	1
R140L	1	Nema 4	No	1
ECIL-1R	1	Nema 1 or 4	Yes	1
R210L	2	Nema1	No	2
R240L	2	Nema 4	No	2
ECIL-2R	2	Nema 1 or 4	Yes	2
R310L	3	Nema1	No	3
R340L	3	Nema 4	No	3
ECIL-3R	3	Nema 1 or 4	Yes	3
R410L	4	Nema1	No	4
R440L	4	Nema 4	No	4
ECIL-4R	4	Nema 1 or 4	Yes	4
R510L	5	Nema1	No	5
R540L	5	Nema 4	No	5
ECIL-5R	5	Nema 1 or 4	Yes	5
R610L	6	Nema1	No	6
R640L	6	Nema 4	No	6
ECIL-6R	6	Nema 1 or 4	Yes	6



Optional Dual Power Supply Diverter

TWIP® Control Units can be wired to operate from two power sources. Operation can switch automatically between power sources A and B in the event of outages.

Water Level Indicator (Optional)

Miniature indicators can alert personnel to presence of water.

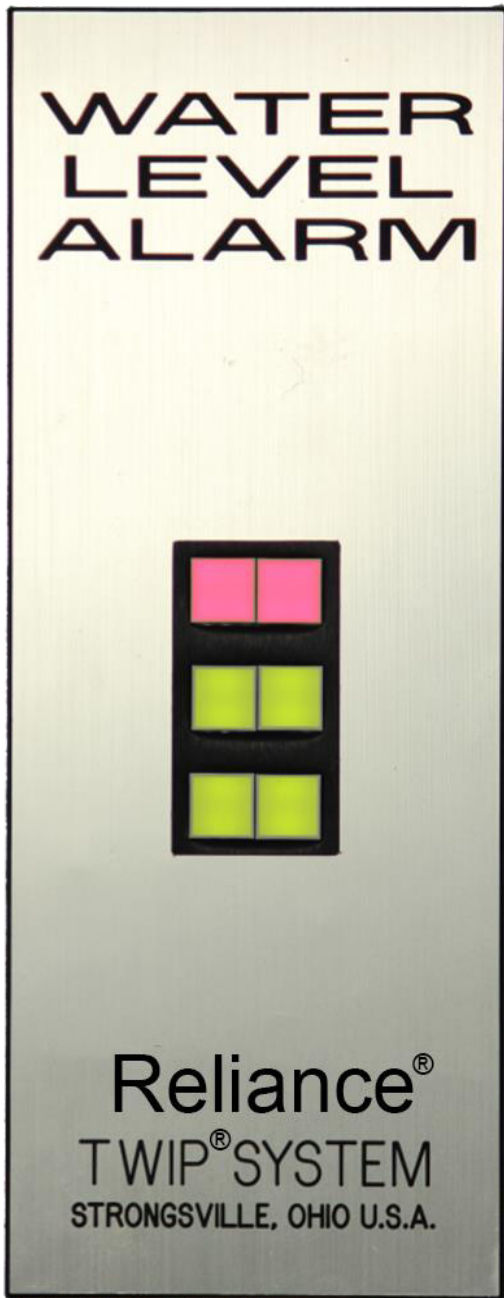

TWIP® Indicators

Model Number	Style	Lights (Red-Green)	Width – in (mm)	Height – in (mm)
MTI-1BT	Miniature	1 R-G	3.00 (76)	7.75 (197)
MTI-1T	Miniature	1 R	3.00(76)	7.75 (197)
SMI-1BT	Sub-Min.	1 R-G	1.12 (28)	5.50 (140)
SMI-1T	Sub-Min.	1 R	1.12 (28)	5.50 (140)
MTI-2BT	Miniature	2 R-G	3.00 (76)	7.75 (197)
MTI-2T	Miniature	2 R	3.00 (76)	7.75 (197)
SMI-2BT	Sub-Min.	2 R-G	1.12 (28)	5.50 (140)
SMI-2T	Sub-Min.	2 R	1.12 (28)	5.50 (140)
MTI-3BT	Miniature	3 R-G	3.00 (76)	7.75 (197)
MTI-3T	Miniature	3 R	3.00 (76)	7.75 (197)
SMI-3BT	Sub-Min.	3 R-G	1.12 (28)	5.50 (140)
SMI-3T	Sub-Min.	3 R	1.12 (28)	5.50 (140)
MTI-4BT	Miniature	4 R-G	3.00 (76)	7.75 (197)
MTI-4T	Miniature	4 R	3.00 (76)	7.75 (197)
SMI-4BT	Sub-Min.	4 R-G	1.12 (28)	5.50 (140)
SMI-4T	Sub-Min.	4 R	1.12 (28)	5.50 (140)
MTI-5BT	Miniature	5 R-G	3.00 (76)	7.75 (197)
MTI-5T	Miniature	5 R	3.00 (76)	7.75 (197)
SMI-5BT	Sub-Min.	5 R-G	1.12 (28)	5.50 (140)
SMI-5T	Sub-Min.	5 R	1.12 (28)	5.50 (140)
MTI-6BT	Miniature	6 R-G	3.00 (76)	7.75 (197)
MTI-6T	Miniature	6 R	3.00 (76)	7.75 (197)
SMI-6BT	Sub-Min.	6 R-G	1.12 (28)	5.50 (140)
SMI-6T	Sub-Min.	6 R	1.12 (28)	5.50 (140)

TWIP® Indicators employ panels of lights to show the presence of water – in a Water Detector chamber or at the location of a sensing Probe installed in plant piping. The Indicator may also be employed to show that a TWIP® System relay has been activated.

One or more Indicators may be quickly and easily installed in control rooms or other key locations throughout the plant. Indicators use light emitting diodes (LEDs) which normally provide more than 10 years of service. LEDs are red or green.

From the World's Largest Selection Of Boiler Instrumentation and Control Devices



Eye-Hye® SmartLevel™
Local and Remote Indicators

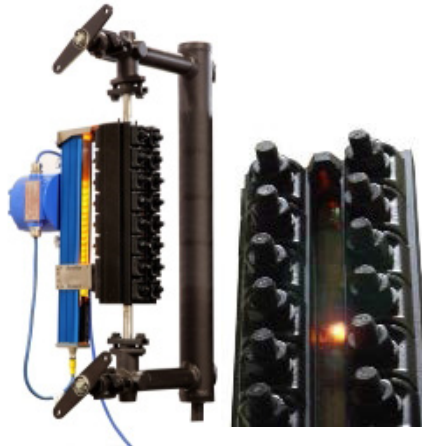

Flat Glass Gages
and **Durastar™** Illuminators



LevelMax
Systems



Simpliport® 180
Water Gage System



Levalarm® Gold
Boiler Level Switches

Maintain Optimum Performance and
Accuracy with OEM Parts

Critical spare parts for overnight delivery,
direct from the manufacturer.



clark-reliance.com/parts



16633 Foltz Parkway, Strongsville, OH 44149 USA Phone: +1.440.572.1500 Fax: +1.440.238.8828
www.clark-reliance.com RelianceAppEng@clark-reliance.com www.relianceboilertrim.com

Clark-Reliance is a registered trademark of The Clark-Reliance Corporation © 2018 The Clark-Reliance® Corporation