



FLOW CONTROLS

Valves | Actuators | Controls



CleanFLOW
An SVF Product Line.

Hygienic Valves | Actuators & Controls

PRODUCT SELECTION GUIDE

SVF Flow Controls Hygienic Ball Valves

The latest ASME-BPE guidelines for valve and tubing designs used in biotech and pharmaceutical applications provides process engineers with a reliable and measurable valve selection criteria.

SVF Flow Controls offers a complete line of fully compliant, hygienic ball valves that meet these stringent guidelines.



CleanFLOW™ ball valves are engineered to be a true process piping component to specifically meet the demanding processes found in the pharmaceutical, biotech, semiconductor, cosmetics, foods and other industries. The port opening of the valve's flow path is dimensionally identical to the adjacent tubing. This "Tube-ID" feature provides predictable flow rates and pressure drops and ensures thorough cleaning and drainability as mandated by ASME-BPE.

As an ASME-BPE compliant product, **CleanFLOW™** valves may be specified and installed plant-wide making the process of design, construction, startup and maintenance easier to manage while helping to minimize overall project costs.

We are pleased to recommend **CleanFLOW™** valves to help you meet the critical demands of an ASME-BPE compliant, high purity piping system.

Only the finest and highest quality materials, available from certified suppliers are used to produce the **CleanFLOW™** ball valve. All materials used are inspected with the most stringent and advanced techniques possible to ensure quality control and superior performance.



CleanFLOW™ Applications:

Pharmaceutical | Biotechnology



- ▶ High Purity Water
- ▶ Clean Steam
- ▶ Gas and Air Delivery
- ▶ Cleaning Solutions
- ▶ Alcohol

Semiconductor | Microelectronics



- ▶ Vacuum
- ▶ High Purity Gases
- ▶ Toxic Gasses
- ▶ Solvents (IPA, Ketones)
- ▶ Tool Hookup

Cosmetics



- ▶ Creams
- ▶ Oils
- ▶ Alcohol
- ▶ Waxes
- ▶ Detergents

SVF Flow Controls Hygienic Ball Valves

CleanFLOW™ Specifically designed for applications in Bio-Pharm

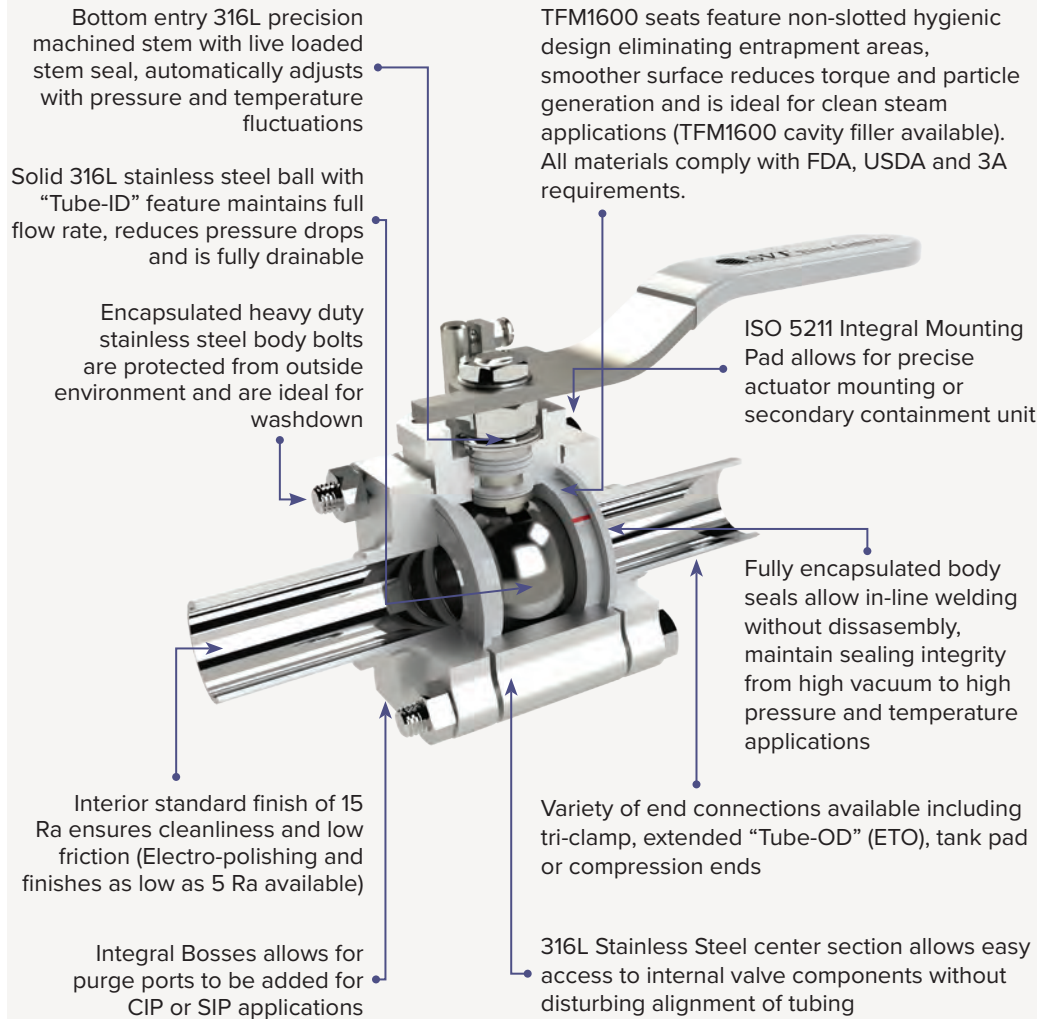

Seats

CleanFLOW™ ball valves feature high-performance TFM1600™ seat materials as a standard. TFM1600™ is chemically modified PTFE that fills the gap between conventional PTFE and melt-processable PFA. Compared to conventional PTFE, TFM1600™ has the following enhanced properties:

- ▶ Much lower deformation under pressure (cold flow) at room and elevated temperatures
- ▶ Lower permeability
- ▶ May be used at higher pressures

Body Seals

CleanFLOW™ encapsulated PTFE body seal design eliminates possible entrapment area between the valve body and the valve ends. It also facilitates inline welding without disassembly. Optional body seal material is available when required.

Our seat and body seal material specifications are as follows:
TFM1600™ and/or PTFE materials:

*(FDA 21 CFR 177.1550, USP Class VI, Sections 87 & 88),
Designed to meet ASME-BPE specifications*

Available Options

Actuation - Pneumatic or electric actuation packages for On/Off or proportional control

Purge Ports - For C.I.P or S.I.P applications

Polishing - Mechanical or electropolishing of interior finish to 5 Ra

Cavity Filler - Seats of TFM1600™ eliminate the dead space between the ball and valve body

Flush Mounted Tank Pad & Zero Dead Leg - Eliminates the dead leg between valve and systems

Handles - Variety of options including Locking, Oval, Extended, Spring Return, Fusible Link and Color Coded

Ends - Variety of options including compression, tri-clamp, extended Tube-OD and tank pad

Materials - Hastelloy, Alloy 20, Monel, AL6XN or Titanium

Stem Extensions & Secondary Containment Unit - Designed to retrofit existing valve.
Prevents possible leaks to outside environment

V-ball Option - Characterized V-ball for controlled flow

O₂ Cleaning - Oxygen Cleaning according to CGA standards

SVF Flow Controls Hygienic Ball Valves

CleanFLOW™ Series SB7 Ball Valve (Cast)

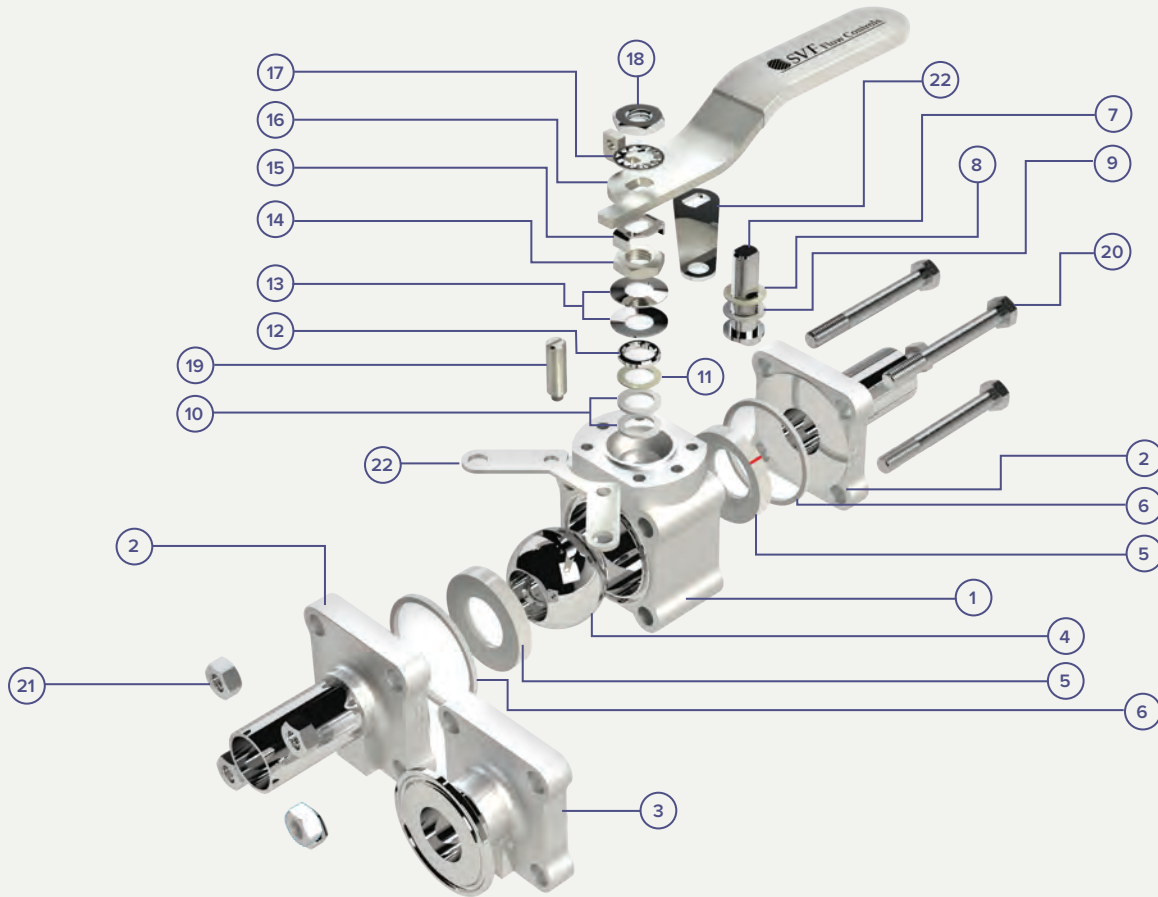

Materials of Construction

ITEM #	DESCRIPTION	MATERIALS SPECIFICATIONS (Additional Options Available)	ITEM #	DESCRIPTION	MATERIALS SPECIFICATIONS (Additional Options Available)
1	Body	ASTM A351 CF3MN/Hastelloy	12	Gland Follower	304 Stainless Steel
2	ETO End	ASTM A351 CF3MN/Hastelloy	13	Belleville Washer	304 Stainless Steel
3	Tri-Clamp End	ASTM A351 CF3MN/Hastelloy	14	Jam Nut	304 Stainless Steel
4	Ball	ASTM A351 CF3MN/Hastelloy	15	Lock Tab	304 Stainless Steel
5	Seat	TFM1600™ (Cavity-Filled Option)	16	Lever Handle	304 Stainless Steel
6	Body Seal	PTFE/ TFM1600™	17	Serrated Lock Washer	304 Stainless Steel
7	Stem	ASTM A351 CF3MN/Hastelloy	18	Handle Nut	304 Stainless Steel
8	Stem Thrust Washer	TFM1600™	19	Stop Pin	304 Stainless Steel
9	Stem Thrust Washer	Virgin PEEK	20	Body Bolt	304 Stainless Steel
10	Stem Seal	TFM1600™	21	Body Nut	304 Stainless Steel
11	Stem Seal	Virgin PEEK	22	Locking Device (Optional)	304 Stainless Steel

SVF Flow Controls Hygienic Ball Valves

Dimensions, Weight and Torque - SB7

Size	A-1		A-2		B		D		L		W		Weight		Cv	Torque* Non-Cavity		Torque* Cavity	
	in.	mm	in.	mm	in.	mm	in.	mm	in.	mm	in.	mm	lbs	kg		in-lbf	Nm	in-lbf	Nm
1/2"	5.50	140	3.50	89	0.37	9	5	114	2.22	56	0.065	1.7	2	0.9	8	60	7	100	11
3/4"	6.00	152	4.00	102	0.62	16	5	114	2.28	58	0.065	1.7	2	0.9	29	60	7	140	16
1"	6.50	165	4.50	114	0.87	22	6	146	2.56	65	0.065	1.7	4	1.8	66	100	11	210	24
1-1/2"	7.50	191	5.50	140	1.37	35	10	254	3.09	78	0.065	1.7	8	3.6	192	200	23	490	55
2"	8.00	203	6.25	159	1.87	47	10	254	3.45	88	0.065	1.7	13	5.9	434	250	28	520	59
2-1/2"	9.50	241	6.75	171	2.37	60	10	254	5.35	136	0.065	1.7	23	10.4	723	450	51	900	102
3"	10.50	267	7.00	178	2.87	73	14	348	6.55	166	0.065	1.7	31	14.1	1124	1300	147	1400	158
4"	12.50	318	8.50	216	3.83	97	22	559	7.14	181	0.083	2.1	46	20.9	2100	1400	158	1500	170
6"	16.00	406	17.00	432	5.78	147	26	660	12.00	305	0.109	2.8	196	88.5	4700	4160	470	-	-

Only PTFE and TFM1600™ are used for the seats and body seals

*At full differential pressure for clean fluids

SB7 Pressure and Temperature Chart

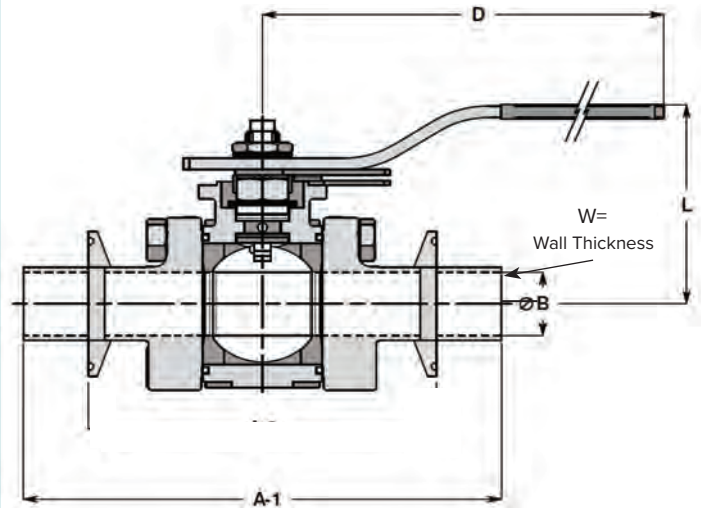
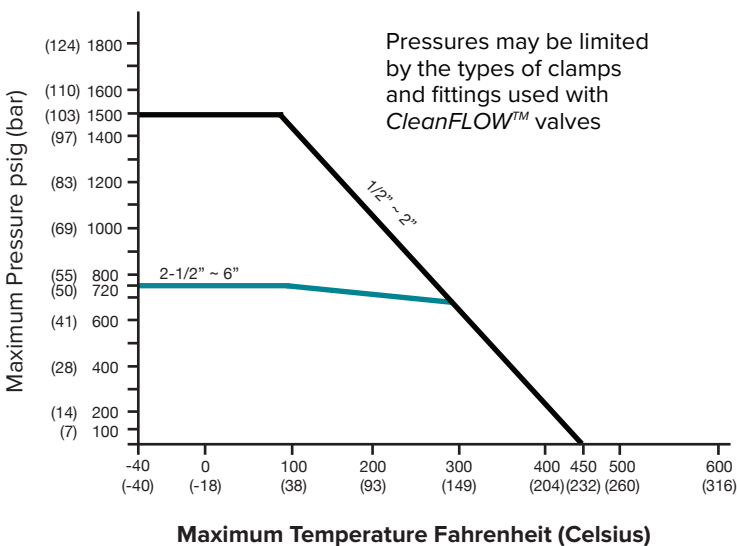

SVF Flow Controls Hygienic Ball Valves

CleanFLOW™ Series SB7F Ball Valve (Forged)

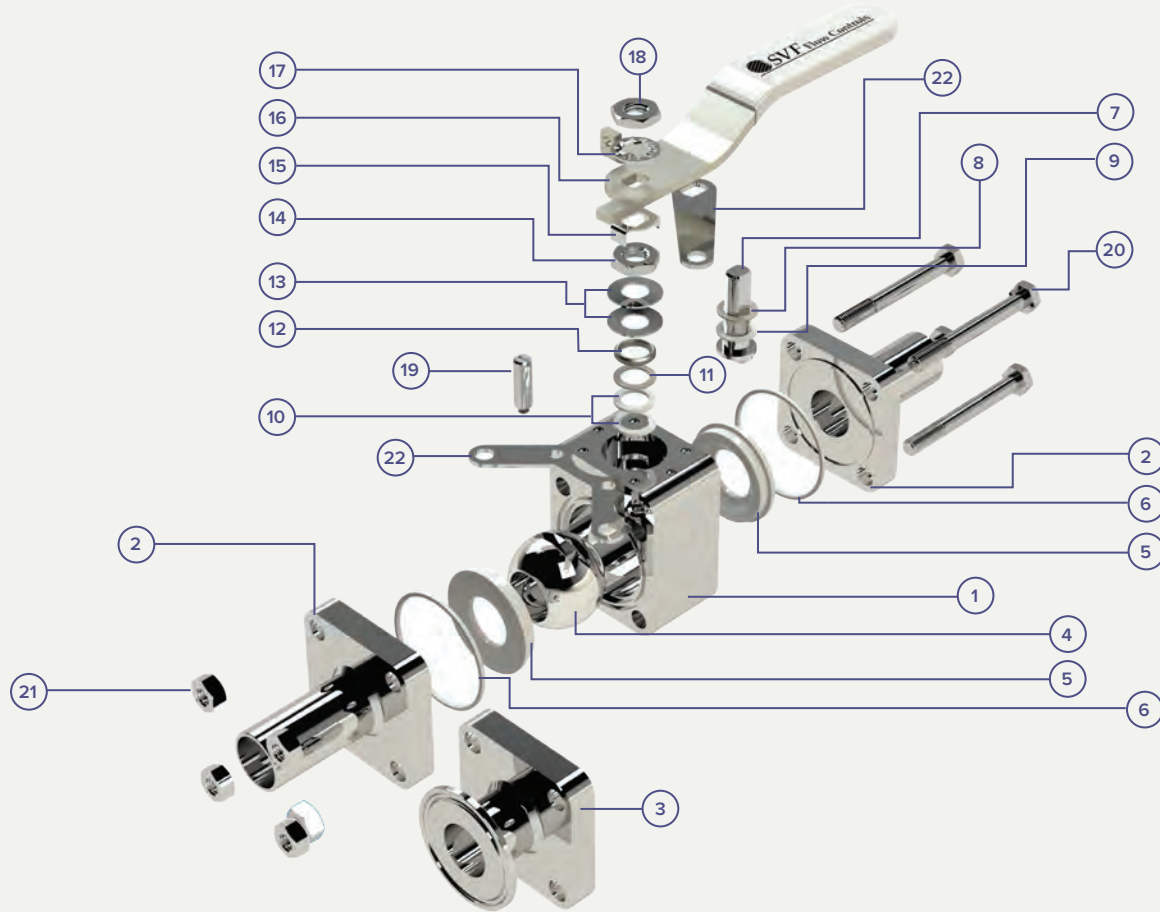

Materials of Construction

ITEM #	DESCRIPTION	MATERIALS SPECIFICATIONS (Additional Options Available)	ITEM #	DESCRIPTION	MATERIALS SPECIFICATIONS (Additional Options Available)
1	Body	A182-F316L	12	Gland Follower	304 Stainless Steel
2	ETO End	A182-F316L	13	Belleville Washer	304 Stainless Steel
3	Tri-Clamp End	A182-F316L	14	Jam Nut	304 Stainless Steel
4	Ball	A182-F316L	15	Lock Tab	304 Stainless Steel
5	Seat	TFM1600™ (Cavity-Filled Option)	16	Lever Handle	304 Stainless Steel
6	Body Seal	TFM1600™	17	Serrated Lock Washer	304 Stainless Steel
7	Stem	A479-316L	18	Handle Nut	304 Stainless Steel
8	Stem Thrust Washer	TFM1600™	19	Stop Pin	304 Stainless Steel
9	Stem Thrust Washer	Virgin PEEK	20	Body Bolt	304 Stainless Steel
10	Stem Seal	TFM1600™	21	Body Nut	304 Stainless Steel
11	Stem Seal	Virgin PEEK	22	Locking Device (Optional)	304 Stainless Steel

SVF Flow Controls Hygienic Ball Valves

Dimensions, Weight and Torque - SB7F

Size	A-1		A-2		B		D		L		W		Weight		Cv	Torque* Non-Cavity		Torque* Cavity	
	in.	mm	in.	mm	in.	mm	in.	mm	in.	mm	in.	mm	lbs	kg		in-lbf	Nm	in-lbf	Nm
1/2"	5.50	140	3.50	89	0.37	9	5	114	2.22	56	0.065	1.7	2	0.9	8	60	7	100	11
3/4"	6.00	152	4.00	102	0.62	16	5	114	2.28	58	0.065	1.7	2	0.9	29	60	7	140	16
1"	6.50	165	4.50	114	0.87	22	6	146	2.56	65	0.065	1.7	4	1.8	66	100	11	210	24
1-1/2"	7.50	191	5.50	140	1.37	35	10	254	3.09	78	0.065	1.7	8	3.6	192	200	23	490	55
2"	8.00	203	6.25	159	1.87	47	10	254	3.45	88	0.065	1.7	13	5.9	434	250	28	520	59
2-1/2"	9.50	241	6.75	171	2.37	60	10	254	5.35	136	0.065	1.7	23	10.4	723	450	51	900	102
3"	10.50	267	7.00	178	2.87	73	14	348	6.55	166	0.065	1.7	31	14.1	1124	1300	147	1400	158
4"	12.50	318	8.50	216	3.83	97	22	559	7.14	181	0.083	2.1	46	20.9	2100	1400	158	1500	170

Only TFM1600™ are used for the seats and body seals

*At full differential pressure for clean fluids

SB7F Pressure and Temperature Chart

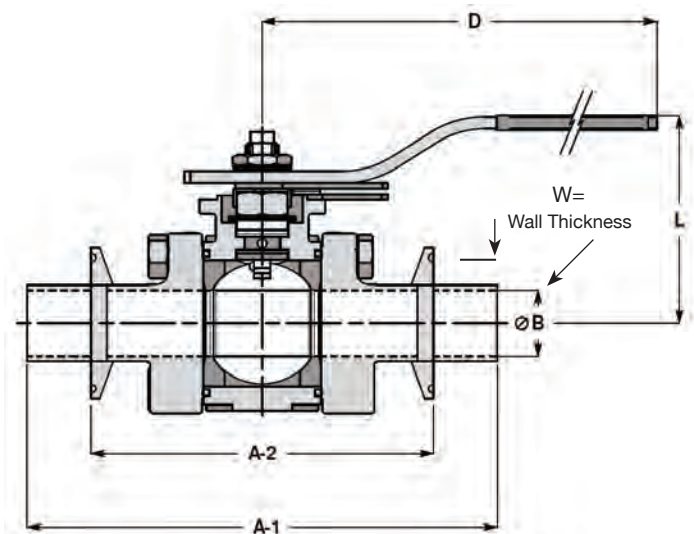
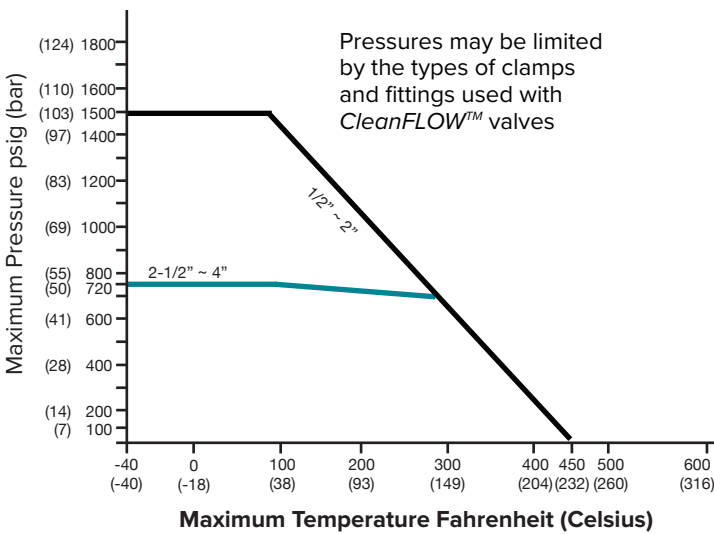

SVF Flow Controls Hygienic Ball Valves

CleanFLOW™ Series SB7X Fire Safe Hygienic Ball Valve

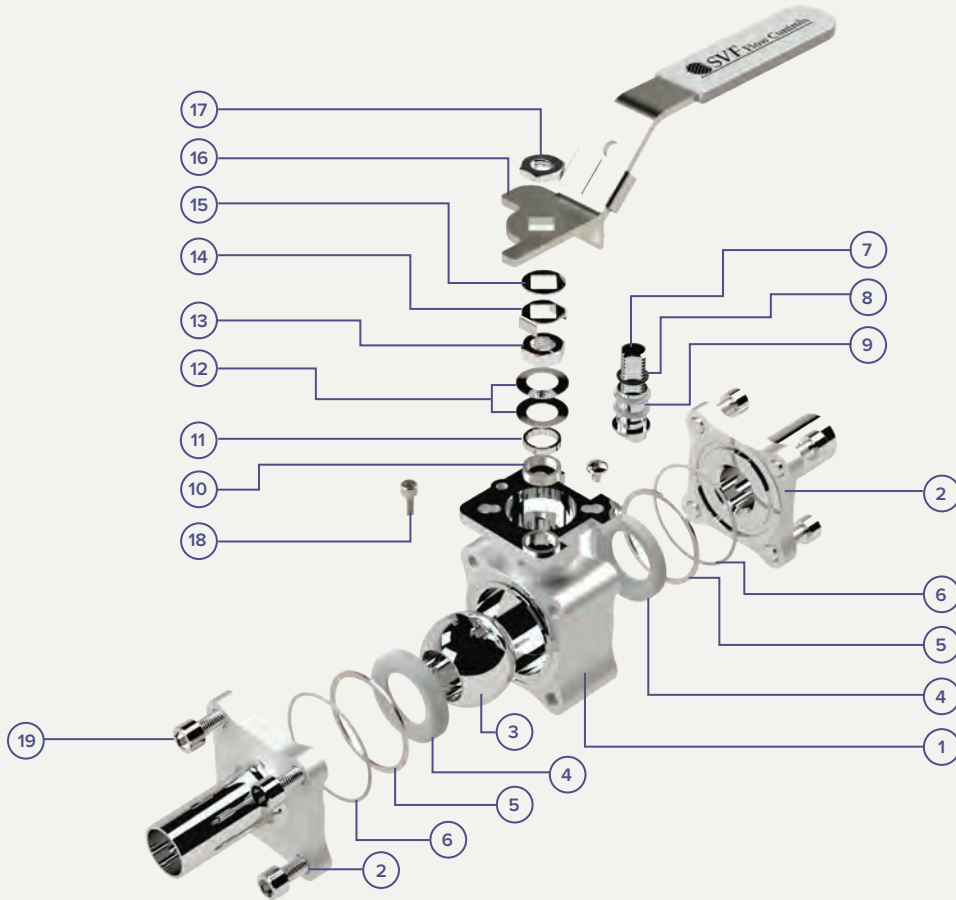

Materials of Construction

ITEM #	DESCRIPTION	MATERIALS SPECIFICATIONS (Additional Options Available)	ITEM #	DESCRIPTION	MATERIALS SPECIFICATIONS (Additional Options Available)
1	Body	ASTM A351 CF3M	11	Gland Follower	304 Stainless Steel
2	ETO End	ASTM A351 CF3M	12	Belleville Washer	304 Stainless Steel
3	Ball	ASTM A351 CF3M	13	Jam Nut	304 Stainless Steel
4	Seat	TFM1600™	14	Lock Tab	304 Stainless Steel
5	Body Seal - 1	PTFE	15	Handle Washer	304 Stainless Steel
6	Body Seal - 2	Grafoil	16	Lever Handle	304 Stainless Steel
7	Stem	ASTM A351 CF3M	17	Handle Nut	304 Stainless Steel
8	O-Ring	Viton	18	Handle Nut	304 Stainless Steel
9	Stem Thrust Washer	PTFE	19	Body Bolt	ASTM A193 B8
10	Stem Seal	Grafoil			

SVF Flow Controls Hygienic Ball Valves

Dimensions, Weight and Torque - SB7X

Size	A		B		D		L		W		Weight		Cv	Torque*	
	in.	mm	in.	mm	in.	mm	in.	mm	in.	mm	lbs	kg		in-lbf	Nm
1/2"	5.3	135	0.37	9	4.4	112	3.1	78	0.065	1.7	2	0.9	8	100	11
3/4"	5.6	142	0.62	16	7.3	186	3.5	89	0.065	1.7	2	0.9	29	140	16
1"	6.0	153	0.87	22	7.3	186	3.9	99	0.065	1.7	4	1.8	66	210	24
1-1/2"	7.0	179	1.37	35	7.8	198	4.9	124	0.065	1.7	8	3.6	192	490	55
2"	7.8	197	1.87	47	7.8	198	5.6	141	0.065	1.7	13	5.9	434	520	59

*At full differential pressure for clean fluids

SB7X Pressure and Temperature Chart

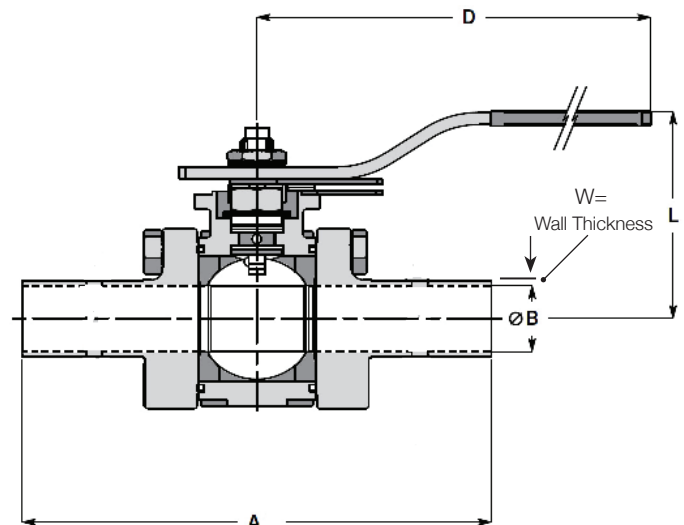
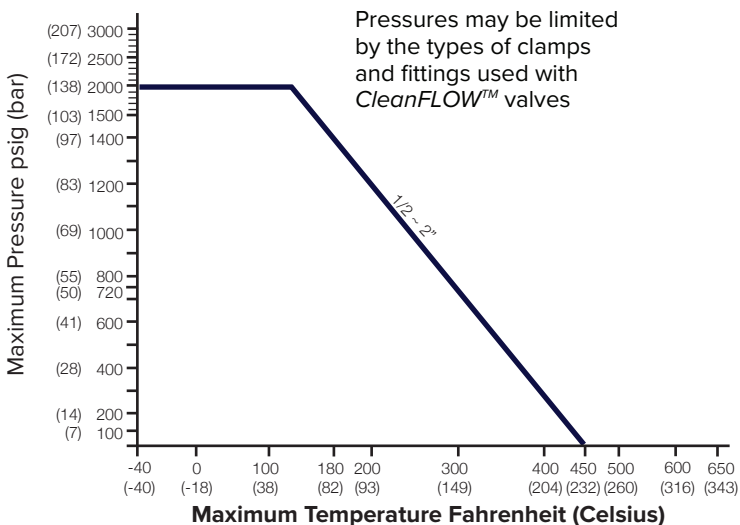

SVF Flow Controls Hygienic Ball Valves

CleanFLOW™ Series TSB7 Ball Valve (Cast)

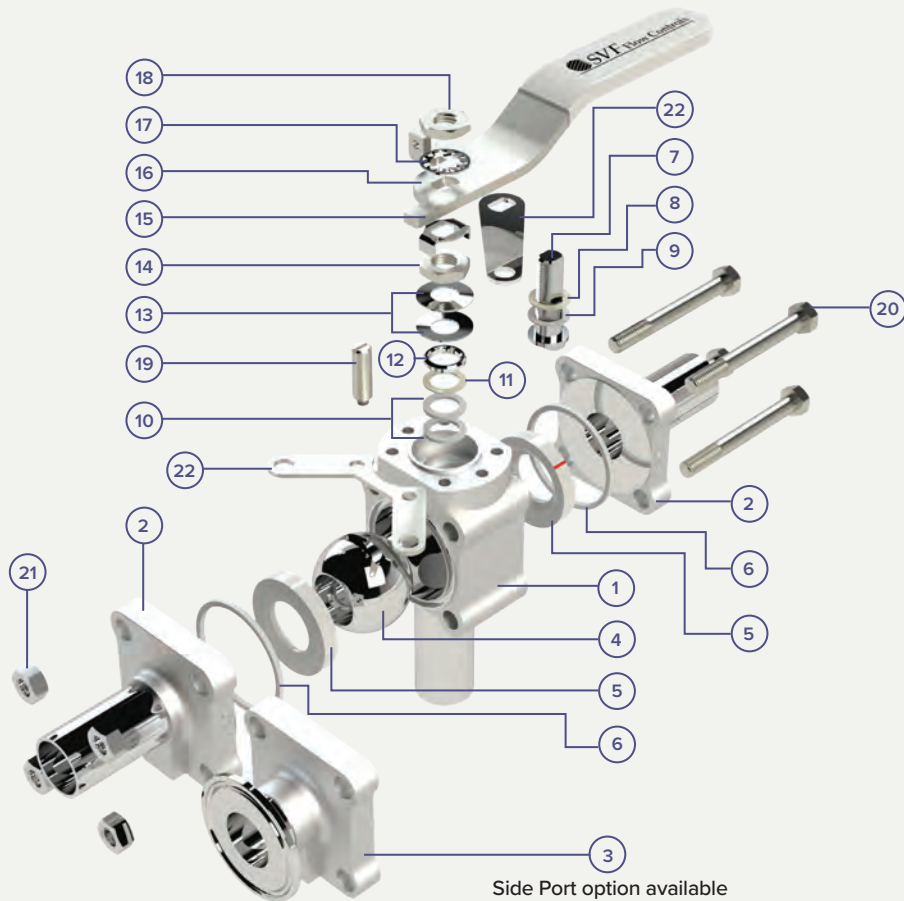

Materials of Construction

ITEM #	DESCRIPTION	MATERIALS SPECIFICATIONS (Additional Options Available)	ITEM #	DESCRIPTION	MATERIALS SPECIFICATIONS (Additional Options Available)
1	Body ETO End	ASTM A351 CF3M	12	Gland Follower	304 Stainless Steel
2	ETO End	ASTM A351 CF3M	13	Belleville Washer	304 Stainless Steel
3	Tri-Clamp End	ASTM A351 CF3M	14	Jam Nut	304 Stainless Steel
4	Ball	ASTM A351 CF3M	15	Lock Tab	304 Stainless Steel
5	Seat	TFM1600™ (Cavity-Filled Option)	16	Lever Handle	304 Stainless Steel
6	Body Seal	PTFE/ TFM1600™	17	Serrated Lock Washer	304 Stainless Steel
7	Stem	ASTM A351 CF3M	18	Handle Nut	304 Stainless Steel
8	Stem Thrust Washer	Virgin PEEK	19	Stop Pin	304 Stainless Steel
9	Stem Thrust Washer	PTFE	20	Body Bolt	304 Stainless Steel
10	Stem Seal	TFM1600™	21	Body Nut	304 Stainless Steel
11	Stem Seal	Virgin PEEK	22	Locking Device (Optional)	304 Stainless Steel

SVF Flow Controls Hygienic Ball Valves

Dimensions, Weight and Torque -TSB7

Size	A-1		A-2		B-1		B-2		C-1		C-2		W		Weight		Cv	Torque* Non-Cavity		Torque* Cavity	
	in.	mm	in.	mm	in.	mm	in.	mm	in.	mm	in.	mm	in.	mm	lbs	kg		in-lbf	Nm	in-lbf	Nm
1/2"	5.50	140	3.50	89	2.96	75	1.67	42	2.96	75	1.67	42	0.065	1.7	2.5	1.1	8	60	7	100	11
3/4"	6.00	152	4.00	102	3.05	77	1.76	45	3.05	77	1.76	45	0.065	1.7	2.5	1.1	29	60	7	140	16
1"	6.50	165	4.50	114	3.23	82	1.95	50	3.23	82	1.95	50	0.065	1.7	4.5	2.0	66	100	11	210	24
1-1/2"	7.50	191	5.50	140	3.58	91	2.30	58	3.58	91	2.30	58	0.065	1.7	9	4.0	192	200	23	490	55
2"	8.00	203	6.25	159	3.74	95	2.46	62	3.74	95	2.46	62	0.065	1.7	15	6.8	434	250	28	520	59
2-1/2"	9.50	241	6.75	171	4.50	114	3.20	81	4.50	114	3.20	81	0.065	1.7	25	11.4	723	450	51	900	102
3"	10.50	267	7.00	178	5.80	147	4.00	102	5.80	147	4.00	102	0.065	1.7	35	15.9	1124	1300	147	-	-
4"	12.50	318	8.50	216	7.00	178	5.00	127	7.00	178	5.00	127	0.083	2.1	52	23.6	2100	1400	158	-	-

Only PTFE and TFM1600™ are used for the seats and body seals

* At full differential pressure for clean fluids

TSB7 Pressure and Temperature Chart

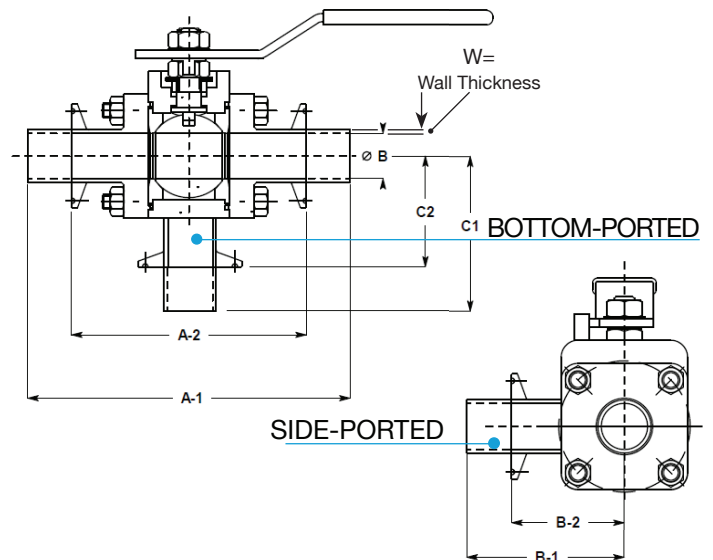
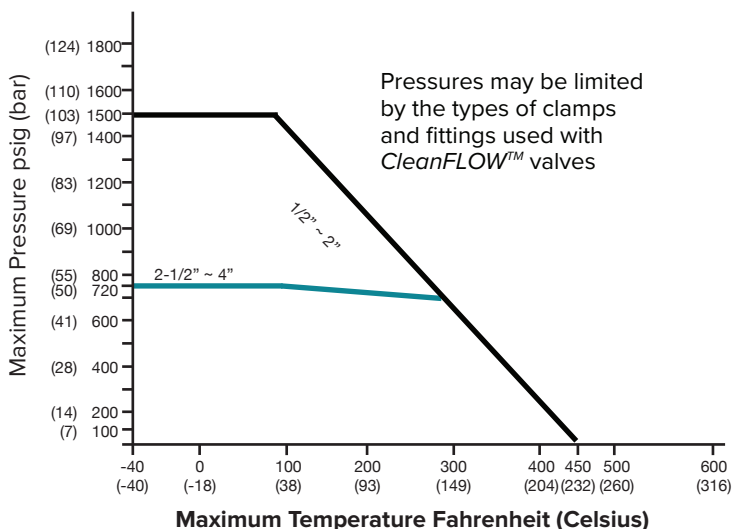

SVF Flow Controls Hygienic Ball Valves

CleanFLOW™ Series TSB7F Ball Valve (Forged)

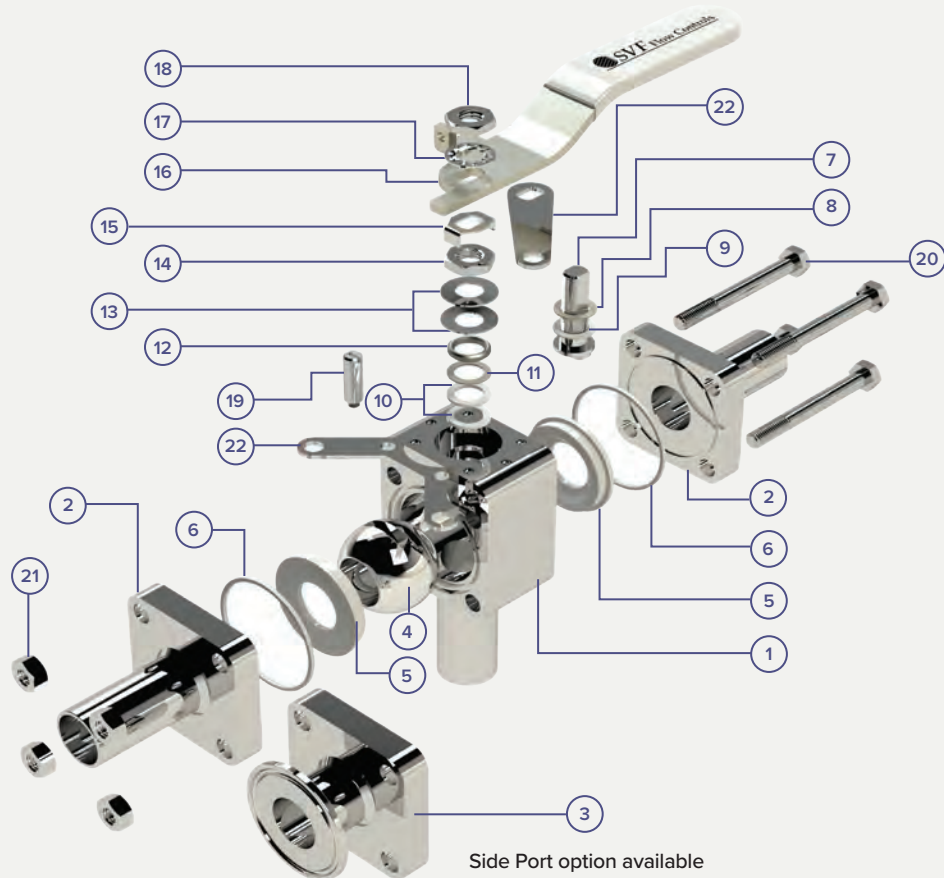

Materials of Construction

ITEM #	DESCRIPTION	MATERIALS SPECIFICATIONS (Additional Options Available)	ITEM #	DESCRIPTION	MATERIALS SPECIFICATIONS (Additional Options Available)
1	Body ETO End	A182-F316L	12	Gland Follower	304 Stainless Steel
2	ETO End	A182-F316L	13	Belleville Washer	304 Stainless Steel
3	Tri-Clamp End	A182-F316L	14	Jam Nut	304 Stainless Steel
4	Ball	A182-F316L	15	Lock Tab	304 Stainless Steel
5	Seat	TFM1600™ (Cavity-Filled Option)	16	Lever Handle	304 Stainless Steel
6	Body Seal	TFM1600™	17	Serrated Lock Washer	304 Stainless Steel
7	Stem	A479-316L	18	Handle Nut	304 Stainless Steel
8	Stem Thrust Washer	TFM1600™	19	Stop Pin	304 Stainless Steel
9	Stem Thrust Washer	Virgin PEEK	20	Body Bolt	304 Stainless Steel
10	Stem Seal	TFM1600™	21	Body Nut	304 Stainless Steel
11	Stem Seal	Virgin PEEK	22	Locking Device (Optional)	304 Stainless Steel

SVF Flow Controls Hygienic Ball Valves

Dimensions, Weight and Torque -TSB7F

Size	A-1		A-2		B-1		B-2		C-1		C-2		W		Weight		Cv	Torque* Non-Cavity		Torque* Cavity	
	in.	mm	in.	mm	in.	mm	in.	mm	in.	mm	in.	mm	in.	mm	lbs	kg		in-lbf	Nm	in-lbf	Nm
1/2"	5.50	140	3.50	89	2.96	75	1.67	42	2.96	75	1.67	42	0.065	1.7	2.5	1.1	8	60	7	100	11
3/4"	6.00	152	4.00	102	3.05	77	1.76	45	3.05	77	1.76	45	0.065	1.7	2.5	1.1	29	60	7	140	16
1"	6.50	165	4.50	114	3.23	82	1.95	50	3.23	82	1.95	50	0.065	1.7	4.5	2.0	66	100	11	210	24
1-1/2"	7.50	191	5.50	140	3.58	91	2.30	58	3.58	91	2.30	58	0.065	1.7	9	4.0	192	200	23	490	55
2"	8.00	203	6.25	159	3.74	95	2.46	62	3.74	95	2.46	62	0.065	1.7	15	6.8	434	250	28	520	59
2-1/2"	9.50	241	6.75	171	4.50	114	3.20	81	4.50	114	3.20	81	0.065	1.7	22	10.0	723	450	51	900	102
3"	10.50	267	7.00	178	5.80	147	4.00	102	5.80	147	4.00	102	0.065	1.7	41	18.6	1124	1300	147	-	-
4"	12.50	318	8.50	216	7.00	178	5.00	127	7.00	178	5.00	127	0.083	2.1	59	26.8	2100	1400	158	-	-

Only TFM1600™ are used for the seats and body seals

* At full differential pressure for clean fluids

TSB7F Pressure and Temperature Chart

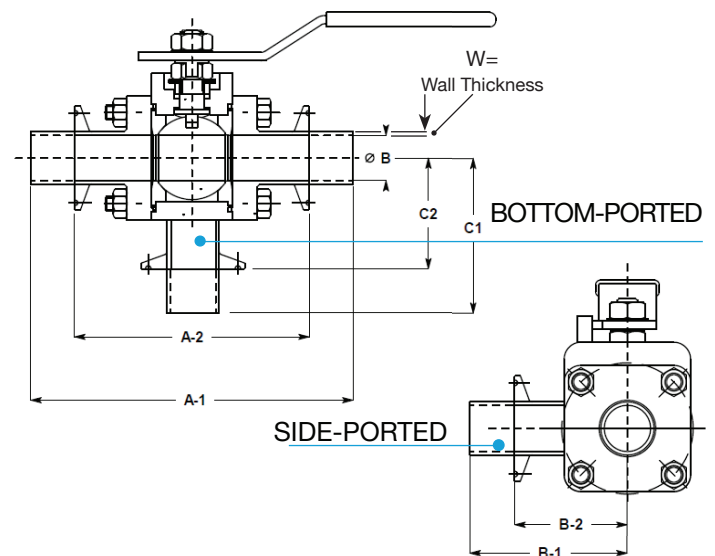
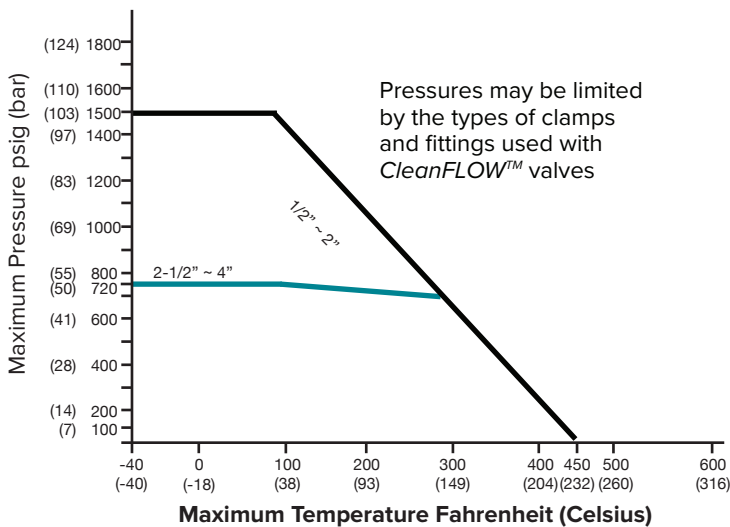

SVF Flow Controls Hygienic Ball Valves

CleanFLOW™ TSB7 / TSB7F Flow Paths

TSB7 and TSB7F Common Flow Paths

At the heart of the TSB7 and TSB7F design is the use of a common port that facilitates directional flow requirements and drainability in the optimal position. The common port “C” may be located at the bottom or the side of the valve. The two most common flow paths are the Side Ported (SL) and the Bottom Ported (BL)*.

*Other flow paths are available.



SL (L-Horizontal) Side Ported Option

This position utilizes an “L-Port” ball and requires quarter-turn operation.

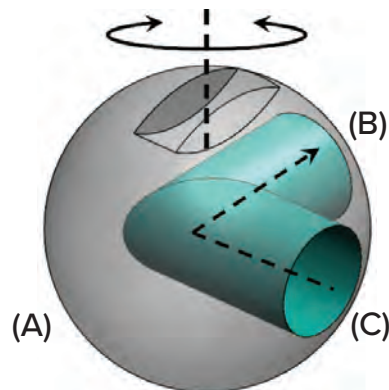
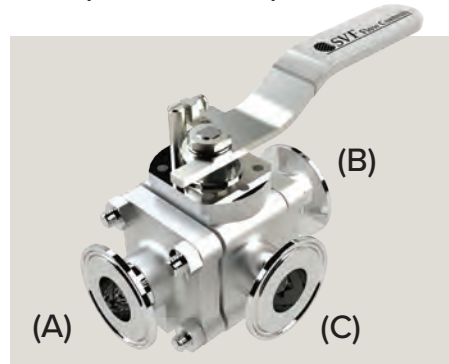

Position (1) Flow (C to B)

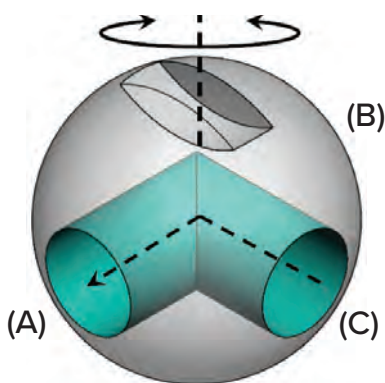

Position (2) Flow (C to A)

BL (LL) Bottom Ported Option

This position utilizes an “LL-Port” ball and requires quarter-turn operation.

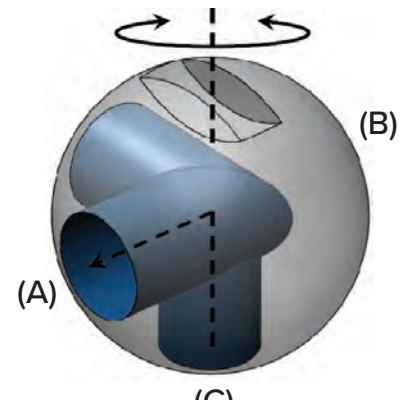
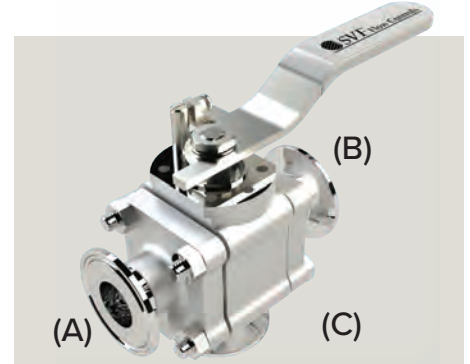

Position (1) Flow (C to A)

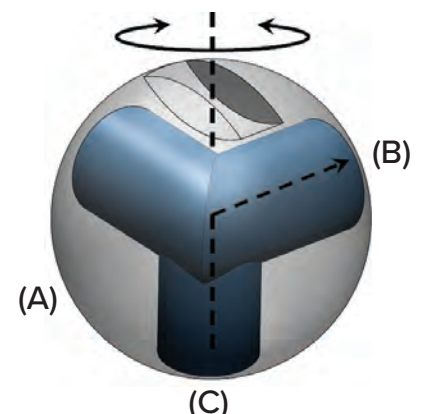

Position (2) Flow (C to B)

SVF Flow Controls Hygienic Ball Valves

Third Port Dimension - Sizes 3" and 4"

TSB7 and TSB7F valves in line sizes 3" and 4" require that the third port be slightly reduced at the valve body due to the lack of material (body width) at the point of weld. The dimensions for the reduction are shown in the table below.

	3" TSB7F		4" TSB7F	
	inch	mm	inch	mm
A = O.D. Dimension	2.50	64	3.00	76
B = I.D. Dimension	2.37	61	2.87	73
B= Tri-Clamp Ferrule I.D.	2.87	73	3.83	97

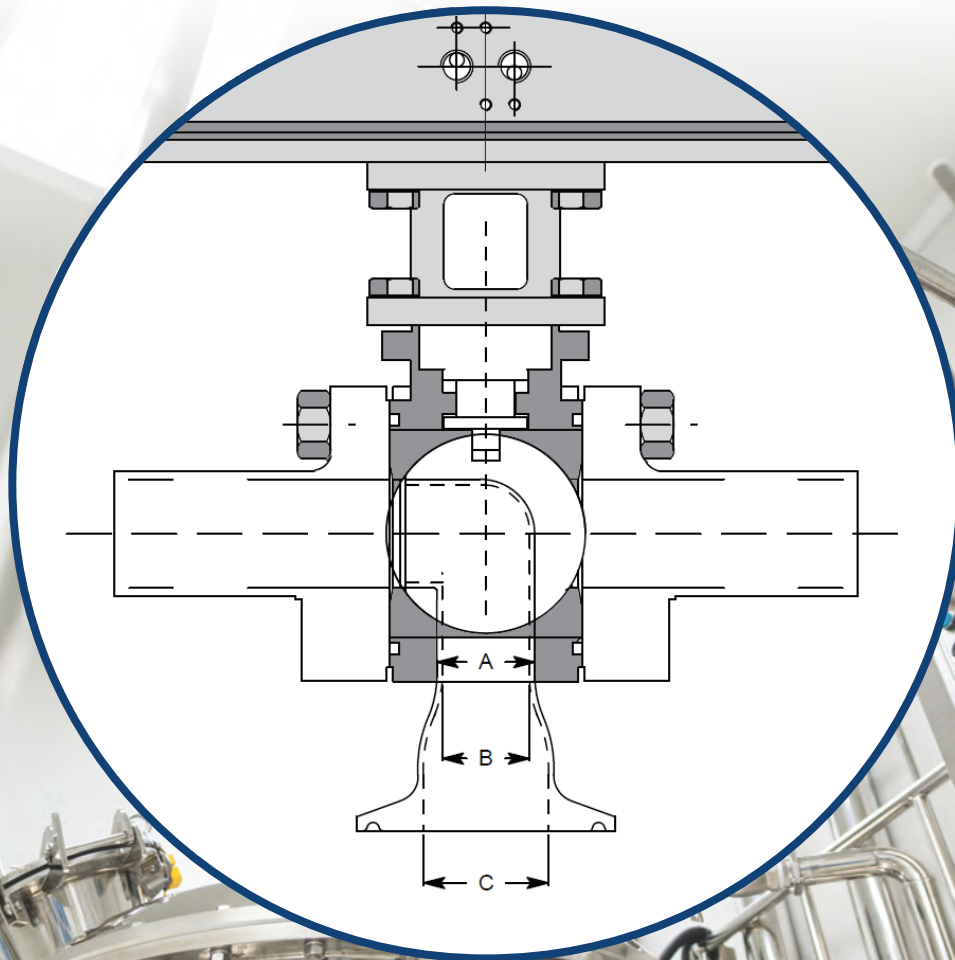

SVF Flow Controls Hygienic Ball Valves

CleanFLOW™ Series SMC9 Ball Valve

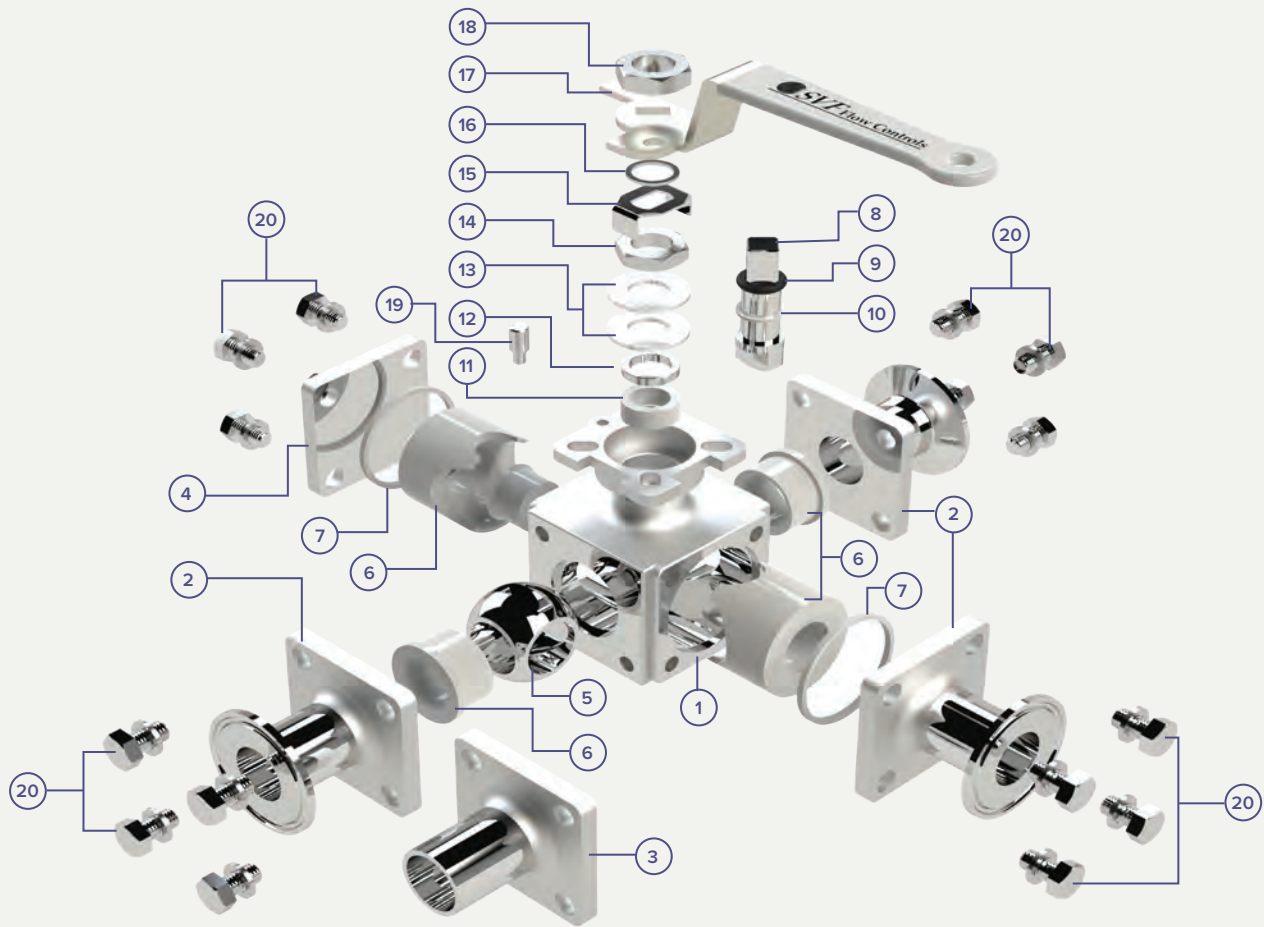

Materials of Construction

ITEM #	DESCRIPTION	MATERIALS SPECIFICATIONS (Additional Options Available)	ITEM #	DESCRIPTION	MATERIALS SPECIFICATIONS (Additional Options Available)
1	Body	ASTM A351 CF-3MN	11	Stem Seal	PTFE
2	Tri-Clamp End	ASTM A351 CF-3MN	12	Gland Follower	304 Stainless Steel
3	ETO End	ASTM A351 CF-3MN	13	Belleville Washer	304 Stainless Steel
4	Blank End	ASTM A351 CF-3MN	14	Stem Nut	304 Stainless Steel
5	Ball	ASTM A351 CF-3MN	15	Lock Tab	304 Stainless Steel
6	Seat	Cavity Filled TFM1600™	16	Spacer	304 Stainless Steel
7	Body Seal	PTFE	17	Lever	304 Stainless Steel
8	Stem	AISI 316	18	Handle Nut	304 Stainless Steel
9	O-Ring	Viton	19	Stop Pin	304 Stainless Steel
10	Stem Thrust Washer	PTFE	20	Body Bolts	304 Stainless Steel

SVF Flow Controls Hygienic Ball Valves

Dimensions, Weight and Torque -SMC9

Size	A1		A2		B-1		B-2		ØB		D		L		W		Weight		Cv	Torque* Cavity	
	in.	mm	in.	mm	in.	mm	in.	mm	in.	mm	in.	mm	in.	mm	lbs	kg	in-lbf	Nm			
1/2"	4.65	118	4.65	118	2.33	59	2.33	59	0.37	9	4.76	121	2.93	74	0.065	1.7	2	1.1	9	79	9
3/4"	5.00	127	5.00	127	2.50	63	2.50	63	0.62	15	4.76	121	3.21	81	0.065	1.7	3	1.3	26	85	10
1"	6.00	152	6.00	152	3.00	76	3.00	76	0.87	22	5.39	137	3.46	88	0.065	1.7	5	2.5	61	110	12
1-1/2"	6.89	175	6.89	175	3.45	87	3.45	87	1.38	35	7.17	182	4.07	103	0.065	1.7	10	4.7	193	290	33
2"	7.48	190	7.48	190	3.74	95	3.74	95	1.87	47	7.17	182	4.42	112	0.065	1.7	15	6.8	432	425	48
2-1/2"	8.98	228	8.98	228	4.49	114	4.49	114	2.37	60	14.57	370	4.42	112	0.065	1.7	27	12.1	728	1085	123
3"	10.26	260	10.26	260	5.13	130	5.13	130	2.87	73	15.75	400	5.08	129	0.065	1.7	36	16.1	1125	1597	180
4"***	11.50	290	11.50	290	5.75	145	5.75	145	2.87	73	15.75	400	5.28	134	0.083	2.1	54	24.4	1986	1780	201

Only PTFE and TFM1600™ are used for the seats and body seals

* At full differential pressure for clean fluids ** 4" is reduced port

SMC9 Pressure and Temperature Chart

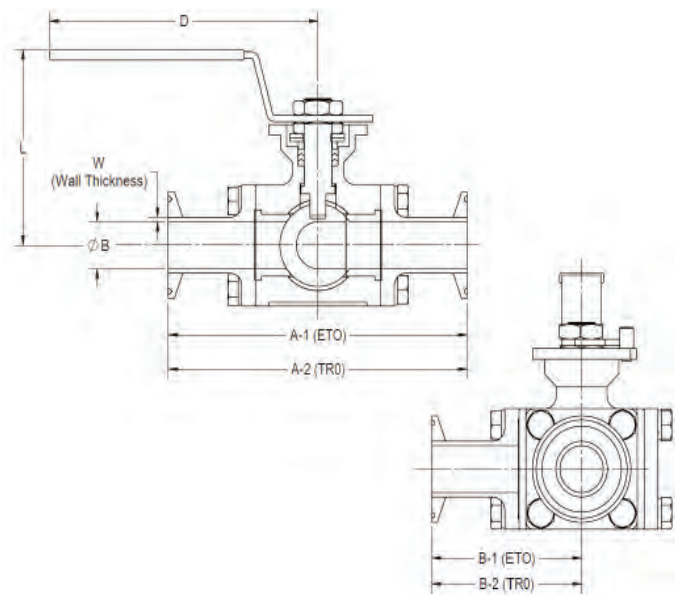
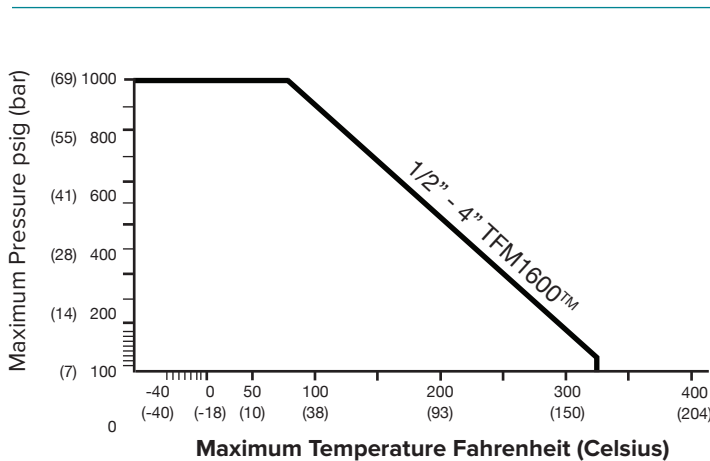

T-PORT FLOW PATHS:

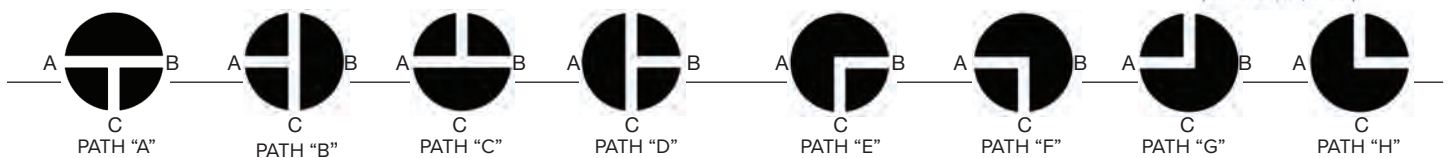

SVF Flow Controls Hygienic Ball Valves

CleanFLOW™ Opus™ Steam Trap Test Valve

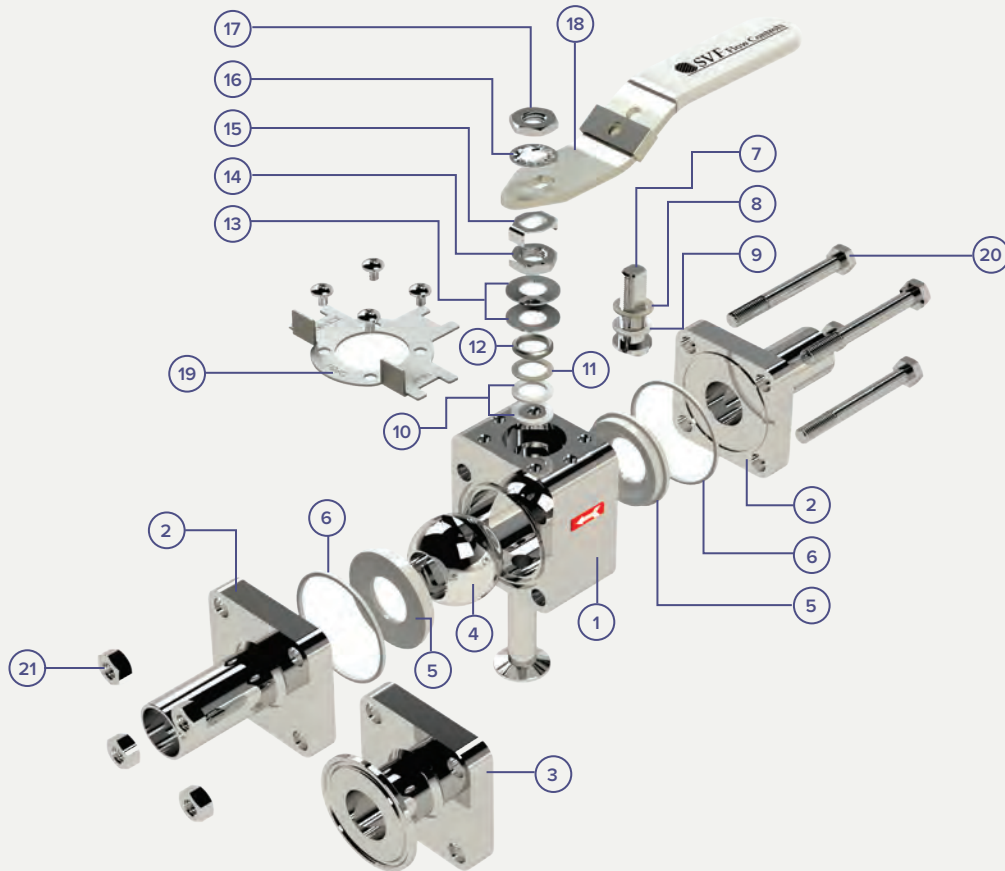

Materials of Construction

ITEM #	DESCRIPTION	MATERIALS SPECIFICATIONS (Additional Options Available)	ITEM #	DESCRIPTION	MATERIALS SPECIFICATIONS (Additional Options Available)
1	Body	ASTM A351 CF3MN/A182-F316L	12	Gland Follower	304 Stainless Steel
2	ETO End	ASTM A351 CF3MN/A182-F316L	13	Belleville Washer	304 Stainless Steel
3	Tri-Clamp End	ASTM A351 CF3MN/A182-F316L	14	Jam Nut	304 Stainless Steel
4	Ball	ASTM A351 CF3MN/A182-F316L	15	Lock Tab	304 Stainless Steel
5	Seat	TFM1600™	16	Serrated Lock Washer	304 Stainless Steel
6	Body Seal	PTFE/TFM1600™	17	Handle Nut	304 Stainless Steel
7	Stem	ASTM A351 CF3MN/A182-F316L	18	Lever	304 Stainless Steel
8	Stem Thrust Washer	TFM1600™	19	Locking Device	304 Stainless Steel
9	Stem Thrust Washer	Virgin PEEK	20	Body Bolt	304 Stainless Steel
10	Stem Seal	TFM1600™	21	Body Nut	304 Stainless Steel
11	Stem Seal	Virgin PEEK			

SVF Flow Controls Hygienic Ball Valves

CleanFLOW™ Opus Flow Paths

Service Position

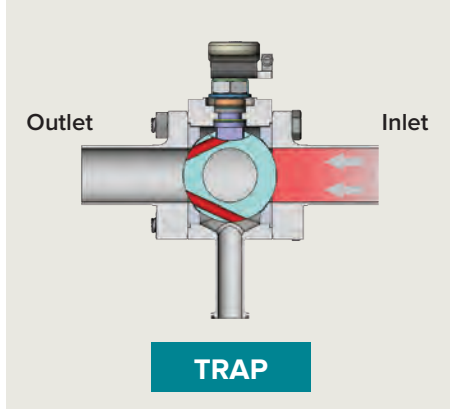

Allows for maintenance of the steam trap by rotating the handle to the Service Position.

In the Service Position, the steam trap is isolated from the steam, allowing the trap to be removed for maintenance.

Once service is completed, return the handle to the Trap or Open Position, based on your needs.

Open Position

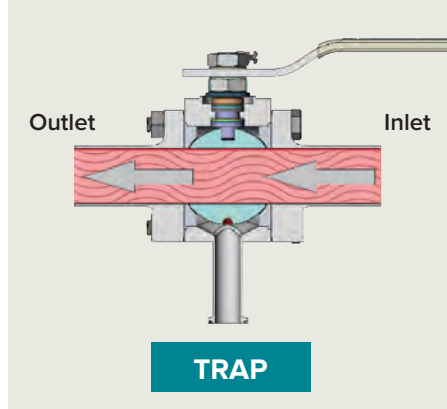

Allows the flow of steam without utilizing the steam trap.

In the Open Position, the steam trap is isolated from the flow allowing sterilization temperature to be reached.

To utilize the steam trap, rotate the handle to the Trap Position. For service, rotate the handle to the Service Position.

Trap Position

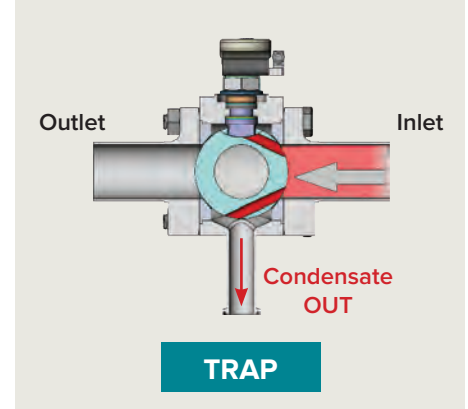

Allows condensate to flow past the ball purge holes during normal operation, bypassing the upstream seat.

In the Trap Position the valve body cavity remains hot.

The point-of-use or sampling connection is isolated by the ball surface.

Opus™ Pressure & Temperature Chart

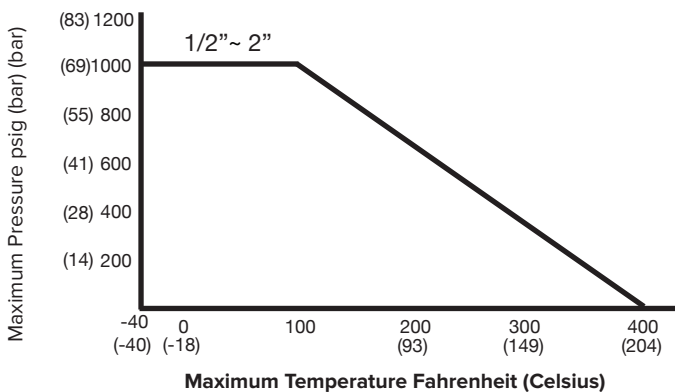

Only PTFE and TFM1600™ are used for the seats and seals.

Manual Operation - Top View

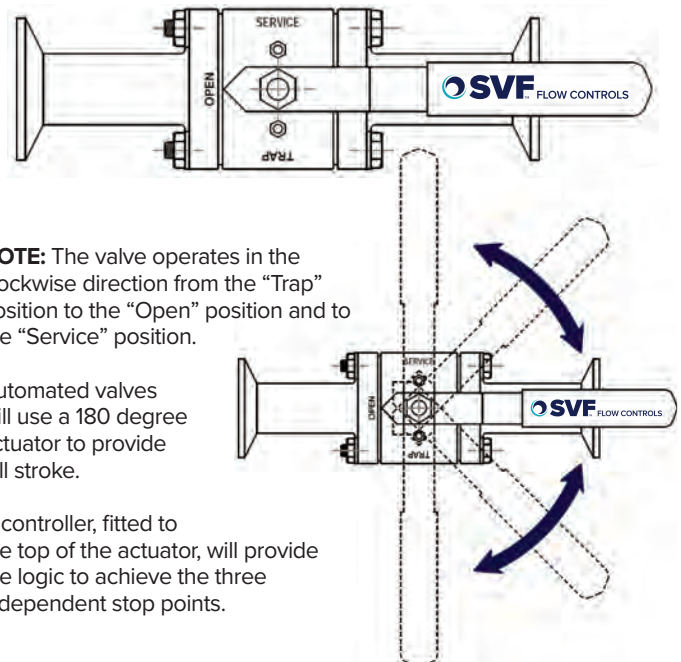

NOTE: The valve operates in the clockwise direction from the “Trap” position to the “Open” position and to the “Service” position.

Automated valves will use a 180 degree actuator to provide full stroke.

A controller, fitted to the top of the actuator, will provide the logic to achieve the three independent stop points.

SVF Flow Controls Hygienic Ball Valves

Configuration Made Easy.

We know that your production needs are as unique as your company. We offer the broadest variety of in-house options anywhere—from seats to seals to alloys and automation accessories. Our highly-trained salespeople and always available engineers can help you find the perfect configuration to keep things flowing.



Stainless Steel Pneumatic Actuators



SB7X with Cast Stem Extension



SB7 with Purge Ports



VSB7 with Quad4 Actuator

SVF Flow Controls Hygienic Ball Valves

Engineered Solutions, Tailored to Meet Your Requirements

SVF designs and manufactures custom valves through our PRO-SPEC program. Here, we develop “process-specific” valves, automated valve and control packages to meet specific process requirements. Some of the custom projects include:

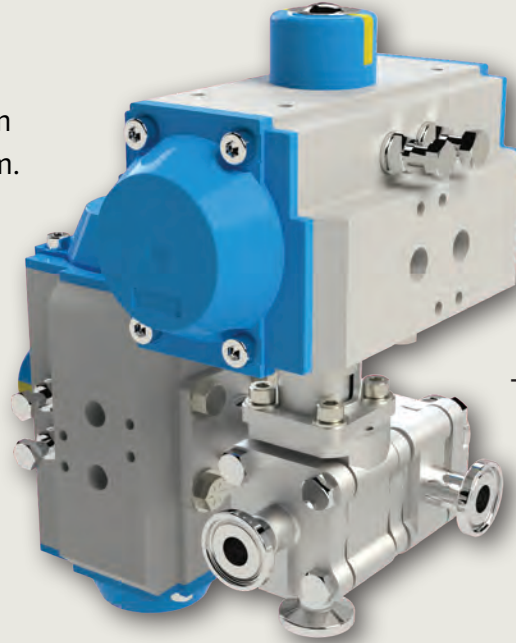

TSB7 Manifold



Tank Bottom Valve



SMC9 with Vacuum Ends Assembly



SB7 with Quad4 Actuator and Nexus PS

SVF Flow Controls Hygienic Ball Valves

How to Order

Order Example: (SB706666ATTR00050000) The Part Number will contain 20 digits.

Ordering Code Sequence	1	2	3	4	5	6	7	8	9	10	11
Sample Part Number	SB70	6	6	6	6	A	T	TRO	005	00	00
	TSB7 Manifold	Valve Series	Body Material	Ball	Stem	Seat Material	Body Seal	End Connections	Valve Size	Options*	Special Services

Ordering Code:

1	2	3	4	5	6
Series	Body	Ends	Ball	Stem	Seat Material
SB70- SB7F - SB7X - TSB7*- TSB7F*- SMC9*-	6 = 316L Stainless Steel	6 = 316L Stainless Steel	6 = 316L Stainless Steel	6 = 316L Stainless Steel	A = TFM1600™ Q = TFM1600™ Cavity Filled

7	8	9	10	11
Body Seal	End Connections	Valve Size	Options**	Special Services**
T = PTFE A = TFM1600™ (6" Size Only)	TRO = Tri-Clamp Ends ETO = Extended Tube- OD Ends JAH = Extended Tube- OD End X Tri-Clamp-End (Extended Tube-OD End is under the valve handle)	005 = 1/2" 007 = 3/4" 010 = 1" 015 = 1-1/2" 020 = 2" 025 = 2-1/2" 030 = 3" 040 = 4" 060 = 6"	00 = Standard Lever Handle LK = Locking Device AA = Oval Handle & Locking Device AC = Locking Device & Anti-Static Device AG = ISO Stem Extension & Locking Device JA = Oval Handle, ISO Stem Extension & Locking Device JB = Oval Handle, ISO Stem Extension & Anti-Static Device JE = Locking Device. ISO Stem Extension & Anti-Static Device TSB7 & TSB7F Ball Options BL = BL3 Ball, 90° Turn, Bottom Port SL = SL1 Ball, 90° Turn, Side Port B2 = BL2 Ball, 180° Turn, Bottom Port SMC9 Port Options T1 = T - Port Ball L1 = L - Post Ball	00 = None XC = Oxygen Cleaned EP = Electropolished SB = 10Ra ID Finish AB = Electropolished & 10Ra ID Finish AD = Oxygen Cleaned & Electropolished JB = Electropolished, Oxygen Cleaned & 10Ra ID Finish

* For options on multi-port valves, please refer to valve datasheets

** Not all Options or Special Services available on all ball valves. Consult SVF for additional information.

Please refer to valve datasheet for complete How-To-Order guides

SVF Flow Controls takes excellence to a new level in the flow control marketplace.

Our extensive product range, highly knowledgeable staff, feature-rich website, digital initiatives and our ongoing customer-focused culture are all part of our role as the best supplier of valve and actuator technologies for demanding industries.

SVF products keep quality flowing all over the world in chemical, petro-chemical, power, pulp & paper, water/wastewater, oil & gas, refining, semiconductor, food & beverage, and pharmaceutical facilities and systems.

As an ISO 9001 certified company, we are committed to quality and continuous improvement in all that we do.

Don't see what you need? No problem! Custom designs and products created to meet exact specifications are our specialty. We welcome all inquiries and consultation needs, and guarantee that our team will work diligently to satisfy your requirements.

Product pricing and availability

U.S. and Canada:

Sales@SVF.net

Latin America:

LatinAmerica@SVF.net

¡Llámanos! ¡

Hablamos español!

Worldwide:

International@SVF.net

Technical Support:

Engineering@SVF.net

World Headquarters

SVF Flow Controls

5595 Fresca Drive, La Palma, CA USA 90623

Toll Free: 1.800.783.7836

On the web: www.SVF.net



Valves | Actuators | Controls

