

Liquid Drainers

	Description	Material	Application
WLD1900 	Float Type with Parallel Pipe Connection	Cast Iron	General Purpose Float Type Liquid Drainer with Cast Iron, Ductile Iron or Stainless Steel Low to moderately high volumes of liquid drainage.
WLD1400 WLDS1400 	Float Type with In-Line Pipe Connection	WLD1400: Ductile Iron WLDS1400: Stainless Steel	
WLDE 	Float Type with Parallel Pipe Connection	WLDE: Ductile Iron WLDES: Cast Steel	Extremely High Capacity
WLD600 	Float Type with In-Line Pipe Connection	WLD600: Cast Steel WLD601: Stainless Steel	Cast Steel or Stainless Steel Body
WLD1800 	Guided Float Type Vertical Connection	Stainless Steel	Corrosive applications. Pressures up to 450 PSIG. Repairable and Non-Repairable versions available.
WLD1500 	Inverted Bucket Style	Cast Iron	Low to medium capacity.
WLD1703S 	Disc Type	Stainless Steel	Very compact size.

Table of Contents

Model	Type	Body Material	PMO (PSIG)	Sizes	Connection	Page No.
WLD1900	Float	Cast Iron	250	3/4" – 2"	NPT	359
WLD1400	Float	Ductile Iron	300	1/2" – 2"	NPT	362
WLDE WLDES	Float Float	Ductile Iron Cast Steel	200 300	1 1/2" - 2 1/2" 2 1/2"	NPT NPT, SW, FLG	364
WLD600 WLD601	Float Float	Carbon Steel 316 Stainless Steel	450	3/4" – 4"	NPT, SW, FLG	366
WLD1800/1800R	Guided Float	Stainless Steel	400	1/2" - 3/4"	NPT	368
WLD1500	Inverted Bucket	Cast Iron	200	3/4" - 1"	NPT	370
WLD1703S	Disc	Stainless Steel	250	1/2"	NPT	372

Universal Style Quick-Change Liquid Drainers available; Consult factory.

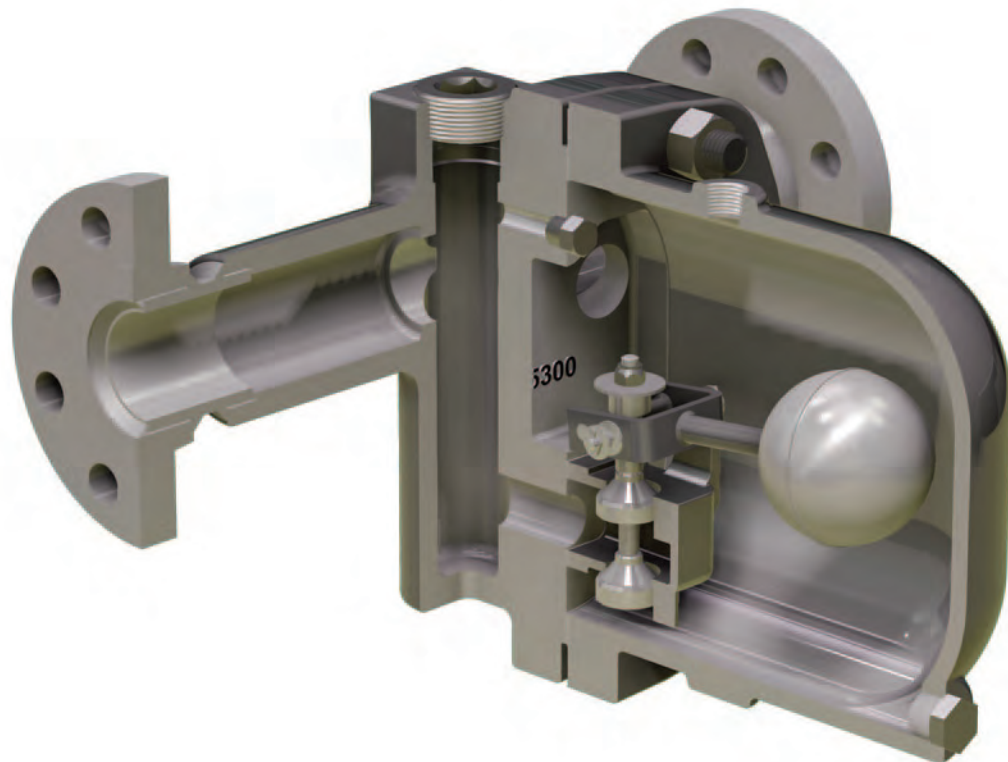

Float Type Liquid Drainer

LIQUID
DRAINERS

Why use Liquid Drainers?

Liquid Drain Traps are primarily used to remove condensation from tanks or pipes containing air or other pressurized gases. The proper liquid drain trap should be selected based on pressure limitation, volume of liquid to be drained and material compatibility.

When are Balancing Lines required?

If a Float Type Liquid Drain Trap is selected, it may be required to add a balancing (or equalizing) line to allow any air or gases trapped in the drainer to escape. If the balancing line is not installed, these gases can prevent proper operation by air-binding the trap. Inverted Bucket Type and Disc Type Drain Traps will self-vent, eliminating the risk of air-binding and therefore do not require balancing lines.

Without a Balancing Line

In applications where the volume of liquid being drained is large enough to fill the complete diameter of the pipe, the potential for air binding exists. This is because Float type drain traps are normally closed, with the weight of the float keeping the valve in the closed position. Liquid must first enter the body of the trap to lift the float and open the valve. When the liquid tries to flow down the pipe, the air pressure inside the trap will continue to build and stop the flow of liquid causing the trap to air bind. A balancing line will equalize the pressure allowing the liquid to freely enter the trap and lift the float, allowing proper discharge to take place.

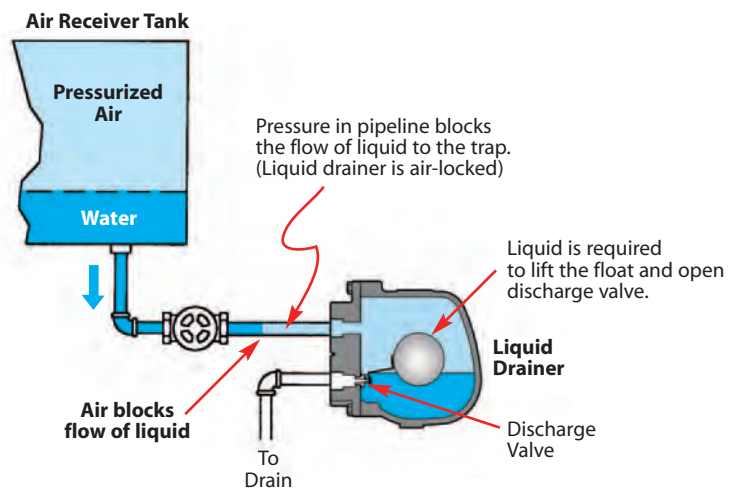

**LIQUID
DRAINERS**

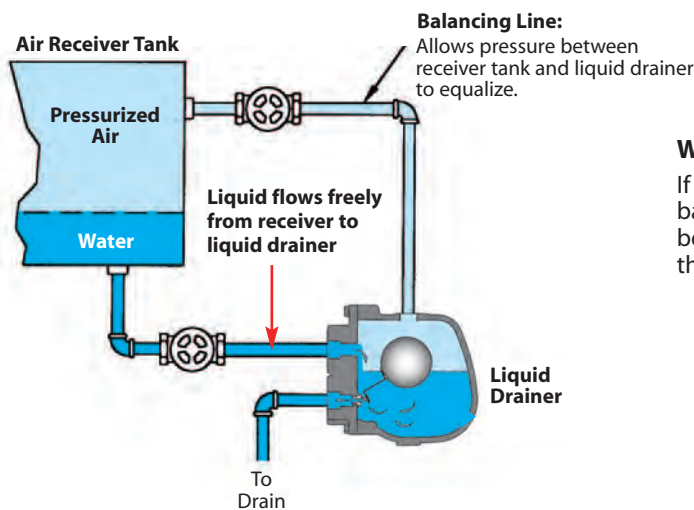

With a Balancing Line

If a Float Type Liquid Drainer is used on a receiver or tank, a balancing line is normally required. The balancing line must be installed above the highest liquid level point to ensure that condensate does not block the balancing line.

Introduction

Some Examples of Liquid Drainer Applications

Figure 1 Draining Condensate from Air Line with a Float Type Liquid Drainer

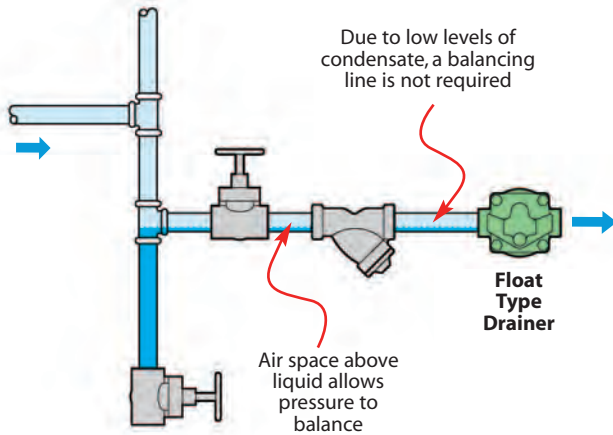

Typically, most air line applications have a low level of condensate to discharge, and the piping does not become flooded with condensate. In this type of application a Float Type Liquid Drainer can be used without the need of a balancing line. Due to the low level of liquid being drained, an air space exists above the liquid in the pipe which balances the pressure allowing liquid to flow freely.

Figure 2 Draining Condensate from a Separator on a Large Air Main

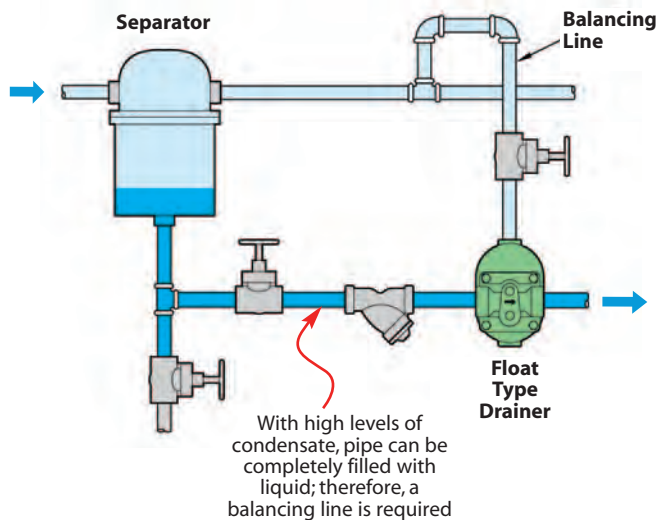

When large loads of condensate are required to be discharged, make sure a properly sized liquid drain trap is used. On large load applications, a balancing line is required, because non-condensable gases can be easily trapped in the drain trap due to fluctuating condensate levels.

Figure 3 Draining Condensate from a Receiver with an Inverted Bucket Style Liquid Drainer

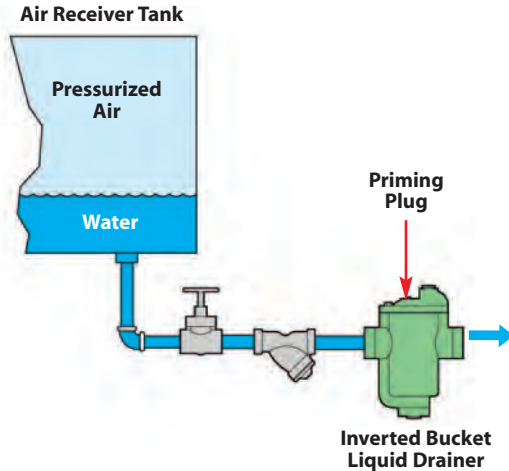

In an application where an Inverted Bucket Liquid Drainer is used, a balancing line may not be required. This style of drainer has a small internal bleed hole on the bucket float which allows a small amount of air to be vented. For the Inverted Bucket Liquid Drain Trap to operate, it must be primed with liquid prior to operation.

Figure 4 Draining Condensate from Drip Leg with a Guided Float Type Liquid Drainer
All Stainless Steel

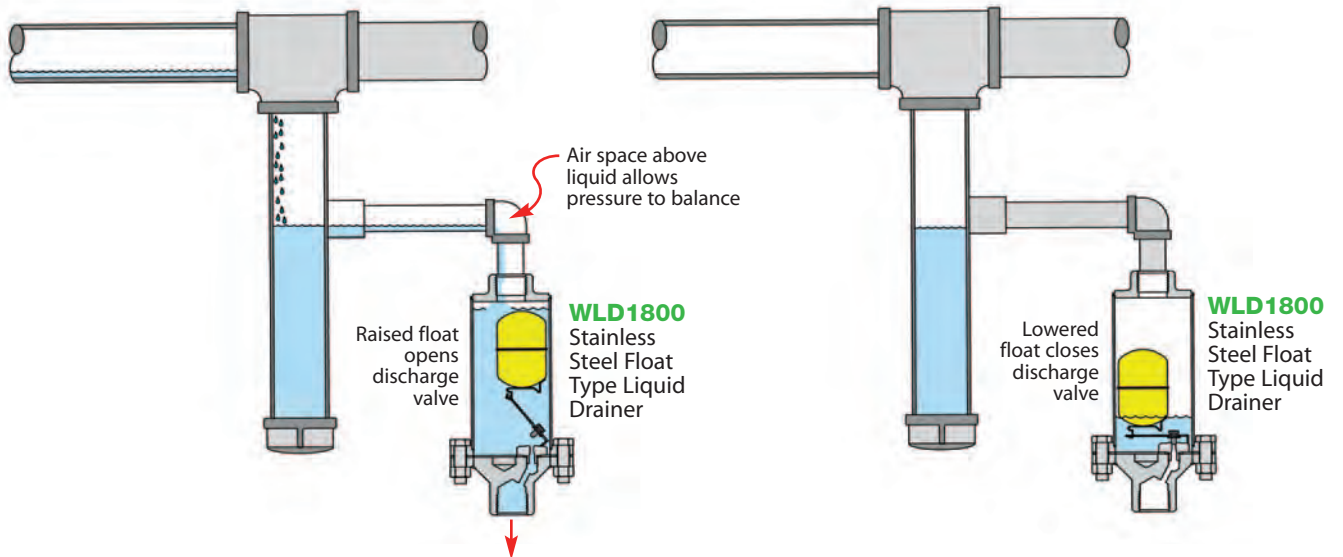

Guided Float Type Liquid Drainers

The Guided Float Type Liquid Drainers are available in either repairable or non-repairable configurations. All Stainless Steel body and internal components are suitable for corrosive applications. In low-flow drip applications, a balancing line is normally not required.

Model	WLD1900
Sizes	3/4", 1", 1 1/4", 1 1/2", 2"
Connections	NPT
Body Material	Cast Iron
PMO Max. Operating Pressure	250 PSIG
TMO Max. Operating Temperature	450°F
PMA Max. Allowable Pressure	250 PSIG up to 450°F
TMA Max. Allowable Temperature	450°F @ 250 PSIG



WLD1900
 3/4" & 1"



WLD1900
 2"

Typical Applications

The **WLD1900 Series** is used in applications where immediate and continuous discharge of liquid is required. Typically used in process applications for draining condensate from air or other gases.

How It Works

The WLD1900 Series liquid drainers contain a float-operated valve. When liquid enters the drainer, the float rises opening the valve which allows liquid to be drained.

Features

- All stainless steel internals
- Hardened valve seat for longer service life
- Cast Iron body
- In-line repairable

Sample Specification

The liquid drain trap shall be float operated with a cast iron body, all stainless steel internals and a hardened valve seat. The unit shall be in-line repairable and equipped with a FNPT threaded connection for the use of a balance line.

Installation

The installation should include isolation valves to facilitate maintenance and an in-line strainer. The trap must be level and upright for the float mechanism to operate. Trap must be adequately sized and properly located in the system. Installation may require an equalizing or balancing line connected from top of drainer body to the above piping, for proper drainage.

Maintenance

All working components can be replaced with the drain trap remaining in the pipeline. Repair kits include float, valve seat & disc, and gaskets. For full maintenance details see Installation and Maintenance Manual.

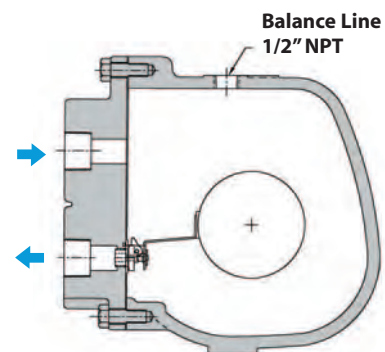

LIQUID DRAINERS

MATERIALS

Body	Cast Iron
Cover	Cast Iron
Gasket	Garlock 3400
Cover Screws	Stainless Steel, Gr 5
Float	Stainless Steel, AISI 304
Internals	Stainless Steel, 300 Series
Valve Seat	Stainless Steel, 17-4 PH
Valve Disc	Stainless Steel, AISI 420F

Liquid Drainers

Float Type Liquid Drainer

WLD1900 Series

Float Type

DIMENSIONS – inches/pounds

Drawing	Model	Size	PMO (PSIG)	Weight (lbs)
A	WLD1913-015	3/4"	15	9
A	WLD1914-015	1"	15	9
A	WLD1915-015	1 1/4"	15	9
C	WLD1916-015	1 1/2"	15	21
D	WLD1917-015	2"	15	53
A	WLD1913-030	3/4"	30	9
A	WLD1914-030	1"	30	9
A	WLD1915-030	1 1/4"	30	9
C	WLD1916-030	1 1/2"	30	21
D	WLD1917-030	2"	30	53
A	WLD1913-090	3/4"	90	9
A	WLD1914-090	1"	90	9
C	WLD1915-090	1 1/4"	90	21
C	WLD1916-090	1 1/2"	90	21
D	WLD1917-090	2"	90	53
A	WLD1913-150	3/4"	150	9
A	WLD1914-150	1"	150	9
C	WLD1915-150	1 1/4"	150	21
C	WLD1916-150	1 1/2"	150	21
D	WLD1917-150	2"	150	53
B	WLD1913-200	3/4"	200	20
B	WLD1914-200	1"	200	20
C	WLD1915-200	1 1/4"	200	21
C	WLD1916-200	1 1/2"	200	21
D	WLD1917-200	2"	200	53
B	WLD1913-250	3/4"	250	20
B	WLD1914-250	1"	250	20
C	WLD1915-250	1 1/4"	250	21
C	WLD1916-250	1 1/2"	250	21
D	WLD1917-250	2"	250	53

LIQUID
DRAINERS

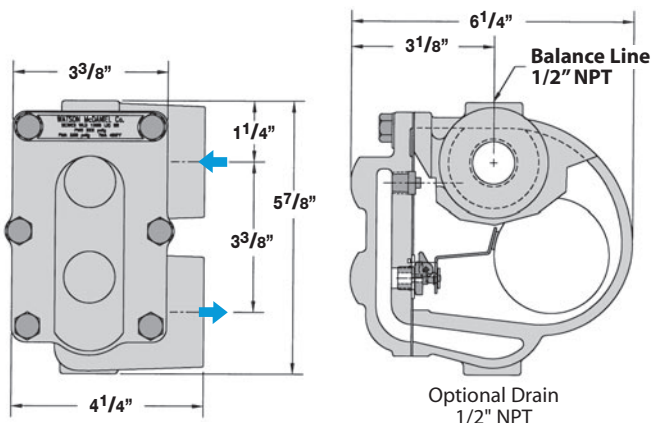

Drawing - A

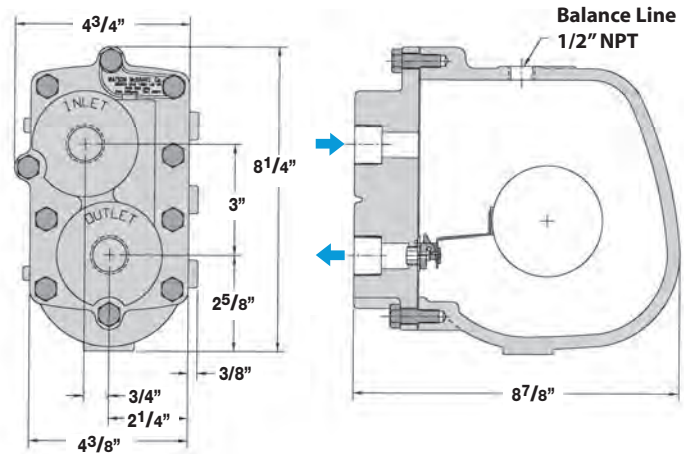

Drawing - B

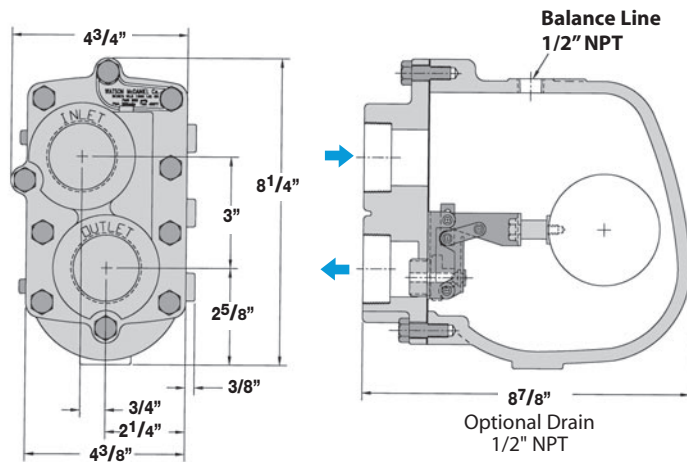

Drawing - C

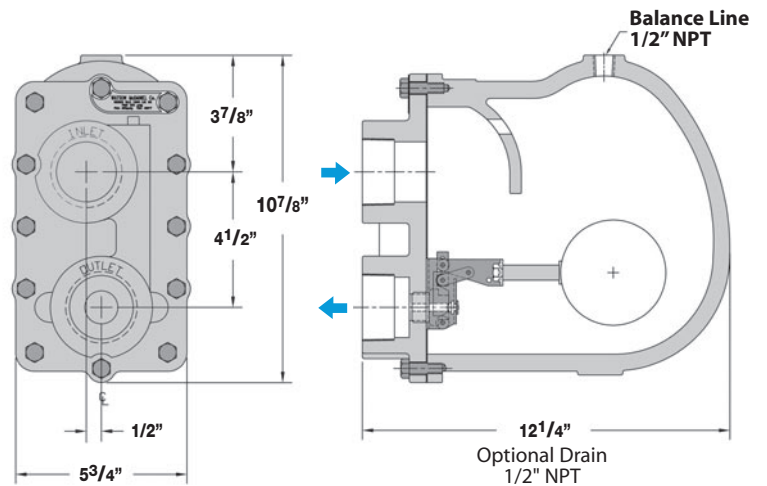

Drawing - D

How to Size / Order

Determine the capacity (lbs/hr) required at the specified differential pressure. Locate differential pressure on capacity chart; move down column to capacity required. Make sure to select the correct model based on the maximum inlet pressure.

Example:

Required to drain 3,000 lbs/hr at a differential pressure of 5 PSI. The maximum inlet pressure is 30 PSIG.

Select Model: **WLD1916-030**, 1 1/2", capacity up to 4,710 lbs/hr based on 5 PSI differential pressure.

Capacity in lbs/hr is based on differential pressure across the drainer. Select a model with an equal or higher PMO (max. operating pressure) than the maximum inlet pressure to the drainer. If the pressure to the drainer exceeds the PMO, the drainer may not open. If discharging to atmosphere, the differential pressure is equal to the inlet pressure.

CAPACITIES – Cold Water (lbs/hr)

Model	Size	PMO* (PSIG)	Orifice Size	Differential Pressure (PSI)																
				1	2	5	10	15	20	30	40	60	90	100	125	150	175	200	225	250
WLD1913-015	3/4"	15	.250"	910	1260	1940	2690	3260												
WLD1914-015	1"	15	.250"	910	1260	1940	2690	3260												
WLD1915-015	1 1/4"	15	.312"	1130	1570	2420	3360	4070												
WLD1916-015	1 1/2"	15	.500"	2400	3330	5140	7140	8650												
WLD1917-015	2"	15	.625"	3000	4170	6430	8920	10810												
WLD1913-030	3/4"	30	.228"	830	1150	1770	2450	2970	3410	4130										
WLD1914-030	1"	30	.228"	830	1150	1770	2450	2970	3410	4130										
WLD1915-030	1 1/4"	30	.228"	830	1150	1770	2450	2970	3410	4130										
WLD1916-030	1 1/2"	30	.390"	2200	3060	4710	6540	7930	9080	11000										
WLD1917-030	2"	30	.500"	2400	3330	5140	7140	8650	9910	12000										
WLD1913-090	3/4"	90	.166"	260	360	550	770	930	1060	1290	1480	1790	2170							
WLD1914-090	1"	90	.166"	260	360	550	770	930	1060	1290	1480	1790	2170							
WLD1915-090	1 1/4"	90	.312"	1130	1570	2420	3360	4070	4660	5650	6470	7830	9500							
WLD1916-090	1 1/2"	90	.312"	1130	1570	2420	3360	4070	4660	5650	6470	7830	9500							
WLD1917-090	2"	90	.422"	1350	1870	2890	4010	4860	5570	6740	7730	9360	11350							
WLD1913-150	3/4"	150	.128"	150	210	330	450	550	630	760	870	1050	1280	1340	1490	1590				
WLD1914-150	1"	150	.128"	150	210	330	450	550	630	760	870	1050	1280	1340	1490	1590				
WLD1915-150	1 1/4"	150	.250"	910	1260	1940	2690	3260	3740	4530	5190	6280	7620	8000	8890	9800				
WLD1916-150	1 1/2"	150	.250"	910	1260	1940	2690	3260	3740	4530	5190	6280	7620	8000	8890	9800				
WLD1917-150	2"	150	.332"	1200	1670	2580	3580	4330	4960	6010	6890	8340	10100	10620	11810	12500				
WLD1913-200	3/4"	200	.166"	260	360	550	770	930	1060	1290	1480	1790	2170	2280	2530	2760	2970	3150		
WLD1914-200	1"	200	.166"	260	360	550	770	930	1060	1290	1480	1790	2170	2280	2530	2760	2970	3150		
WLD1915-200	1 1/4"	200	.250"	910	1260	1940	2690	3260	3740	4530	5190	6280	7620	8000	8890	9690	10420	11100		
WLD1916-200	1 1/2"	200	.250"	910	1260	1940	2690	3260	3740	4530	5190	6280	7620	8000	8890	9690	10420	11100		
WLD1917-200	2"	200	.281"	1960	2720	4200	5830	7060	8090	9800	11230	13600	16500	17320	19250	20980	22570	23800		
WLD1913-250	3/4"	250	.128"	150	210	330	450	550	630	760	870	1050	1280	1340	1490	1630	1750	1860	1970	2070
WLD1914-250	1"	250	.128"	150	210	330	450	550	630	760	870	1050	1280	1340	1490	1630	1750	1860	1970	2070
WLD1915-250	1 1/4"	250	.203"	600	830	1280	1770	2150	2460	2980	3420	4140	5020	5270	5860	6390	6870	7320	7740	8140
WLD1916-250	1 1/2"	250	.203"	600	830	1280	1770	2150	2460	2980	3420	4140	5020	5270	5860	6390	6870	7320	7740	8140
WLD1917-250	2"	250	.250"	910	1260	1940	2690	3260	3740	4530	5190	6280	7620	8000	8890	9690	10420	11100	11740	12340

LIQUID
DRAINERS

*PMO based on a liquid with a specific gravity of 1.0. Consult factory for the PMO of a liquid specific gravity less than 1.0.



Model	WLD1400	WLDS1400
Sizes	1/2" - 2"	1/2" - 1"
Connections	NPT, 150# FLG (1" - 2")	NPT, SW 150#/300# FLG
Body Material	Ductile Iron	316 Stainless Steel
PMO Max. Operating Pressure	300 PSIG	225 PSIG
TMO Max. Operating Temperature	450°F	
PMA Max. Allowable Pressure	300 PSIG up to 450°F	
TMA Max. Allowable Temperature	450°F @ 300 PSIG	

WLD140: 1/2" & 3/4" available in NPT only.
WLDS1400: Available in 1/2" -1" only;
 Capacities same as 1/2" - 3/4" WLD1400.

Typical Applications

The **WLD1400 & WLDS1400 Series** is used on air and gas applications as drip traps on piping runs as well as drainage for systems and various process vessels that have moderate condensate loads.

How It Works

The **WLD1400 & WLDS1400 Series** liquid drainers contain a float-operated valve. When liquid enters the drainer, the float rises opening the valve which allows liquid to be drained.

Features

- All stainless steel internals
- Hardened valve seat for longer service life
- Ductile Iron or Stainless Steel body
- In-line repairable

Options

- Drain connection - WLD1400: 1"-2"; WLDS1400: all sizes
- WLDS1400 only - Left, Right, or Vertical (downward) flow direction

MATERIALS

Body & Cover WLD1400	Ductile Iron
Body & Cover WLDS1400	CF8M Stainless Steel
Gasket	Garlock 3400
Cover Screws	Stainless Steel, Gr 5
Float	Stainless Steel, AISI 304
Internals	Stainless Steel, 300 Series
Valve Seat	Stainless Steel, 17-4 PH
Valve Disc	Stainless Steel, AISI 420F

Sample Specification

The liquid drain trap shall be float operated with a ductile iron or stainless steel body, all stainless steel internals and a hardened valve seat. The unit shall be in-line repairable and equipped with a FNPT threaded connection for the use of a balance line.

Installation

The installation should include isolation valves to facilitate maintenance and an in-line strainer. The trap must be level and upright for the float mechanism to operate. Trap must be adequately sized and properly located in the system. Installation may require an equalizing or balancing line connected from top of drainer body to the above piping, for proper drainage.

Maintenance

All working components can be replaced with the drain trap remaining in the pipeline. Repair kits include float, valve seat & disc, and gaskets. For full maintenance details see Installation and Maintenance Manual.

Liquid Drainers

Float Type Liquid Drainer

WLD1400/WLDS1400 Series

Float Type

WLD1400 1/2" & 3/4" • WLDS1400 1/2", 3/4" & 1"

WLD1400 1"

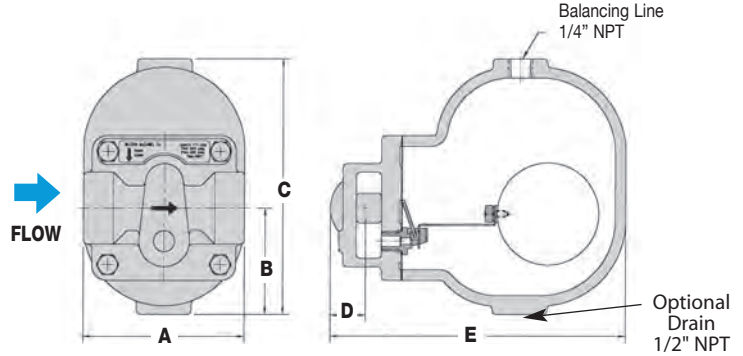
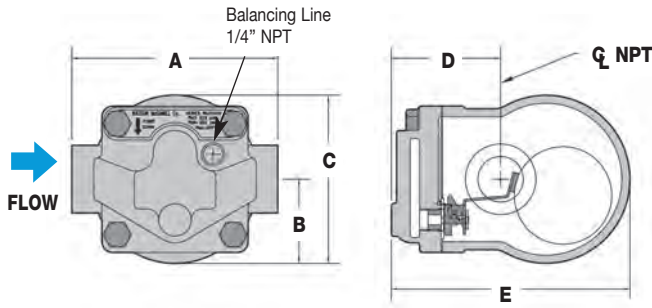

WLD1400 1 1/2" & 2"

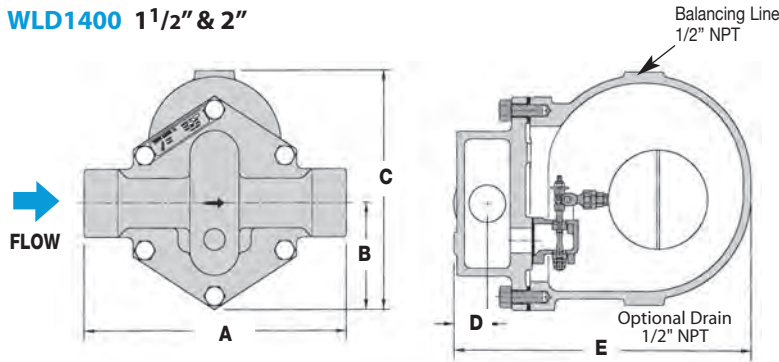

DIMENSIONS & WEIGHTS – inches/pounds						
Size	A	B	C	D	E	Weight
1/2", 3/4"	4.8	1.9	3.9	2.5	5.5	6
1"	4.8	3.1	7.5	1.1	8.8	16
1 1/2"	10.6	4.3	9.6	1.4	12	40
2"	11.9	4.3	9.6	1.4	12	40

Note: For flanged dimensions, refer to FTT and FTTS Steam Trap pages.

How to Size / Order

Determine the capacity (lbs/hr) required at the specified differential pressure. Locate differential pressure on capacity chart; move down column to capacity required. Make sure to select the correct model based on the maximum inlet pressure.

Example:

Required to drain 3,500 lbs/hr at a differential pressure of 2 PSI. The maximum inlet pressure is 15 PSIG.

Select Model: **WLD1416-N-065**, 1 1/2", capacity up to 4,300 lbs/hr based on 2 PSI differential pressure. PMO = 65 PSI

Capacity in lbs/hr is based on differential pressure across the drainer. Select a model with an equal or higher PMO (max. operating pressure) than the maximum inlet pressure to the drainer. If the pressure to the drainer exceeds the PMO, the drainer may not open. If discharging to atmosphere, the differential pressure is equal to the inlet pressure.

CAPACITIES – Cold Water (lbs/hr)				For WLD1400 & WLDS1400																	
Model Code	Size	PMO* (PSIG)	Orifice Size	Differential Pressure (PSI)																	
				1	2	5	10	15	20	30	50	65	75	100	125	145	200	225	300		
WLD1412-N-065	1/2"	65	.157"	250	340	530	730	880	1010	1230	1560	1770									
WLD1413-N-065	3/4"	65	.157"	250	340	530	730	880	1010	1230	1560	1770									
WLD1414-N-065	1"	65	.273"	980	1360	2090	2910	3520	4040	4890	6220	7050									
WLD1416-N-065	1 1/2"	65	.690"	3125	4300	6600	9350	11225	13250	16350	20950	23500									
WLD1417-N-065	2"	65	1.12"	10600	14900	23300	31500	38150	44750	53600	69200	76375									
WLD1412-N-145	1/2"	145	.100"	110	150	230	320	380	440	530	680	770	940	1050	1130	1200					
WLD1413-N-145	3/4"	145	.100"	110	150	230	320	380	440	530	680	770	940	1050	1130	1200					
WLD1414-N-145	1"	145	.202"	490	670	1040	1440	1750	2000	2430	3090	3500	4290	4760	5110	5350					
WLD1416-N-145	1 1/2"	145	.590"	1575	2175	3400	4650	5525	6325	7750	9925	11000	12300	13975	15300	16500					
WLD1417-N-145	2"	145	.806"	3875	5450	8575	11500	12350	13200	20950	27175	31050	34150	38500	42225	45950					
WLD1412-N-225	1/2"	225	.079"	60	80	130	180	220	250	300	380	430	530	590	630	690	740	780			
WLD1413-N-225	3/4"	225	.079"	60	80	130	180	220	250	300	380	430	530	590	630	690	740	780			
WLD1414-N-225	1"	225	.184"	320	450	690	960	1160	1330	1610	2050	2330	2850	3170	3400	3710	3960	4100			
WLD1416-N-250	1 1/2"	250	.530"	1000	1375	2150	3050	3600	4100	5025	6400	7300	8050	8900	9750	10550	12450	13150			
WLD1417-N-250	2"	250	.650"	1900	2675	4250	5850	7000	8225	10050	12950	15125	16700	18300	20200	22100	25850	27100			
WLD1414-N-300	1"	300	.153"	230	320	500	690	840	960	1170	1480	1680	2060	2290	2460	2680	2860	3020	3460		

Note: 1/2" - 1" WLDS1400 capacities same as 1/2" - 3/4" WLD1400 capacities.

* PMO based on a liquid with a specific gravity of 1.0. Consult factory for the PMO of a liquid with specific gravity less than 1.0.

LIQUID
DRAINERS

Liquid Drainers

Float Type Liquid Drainer

WLDE/WLDES Series

Float Type

Model	WLDE	WLDES
Sizes	1 1/2", 2", 2 1/2"	2 1/2"
Connections	NPT	NPT, SW, Flanged
Body Material	Ductile Iron	Cast Steel
PMO Max. Operating Pressure	200 PSIG	300 PSIG
TMO Max. Operating Temperature	450°F	450°F
PMA Max. Allowable Pressure	300 PSIG up to 450°F	300 PSIG up to 750°F
TMA Max. Allowable Temperature	450°F @ 300 PSIG	750°F @ 300 PSIG

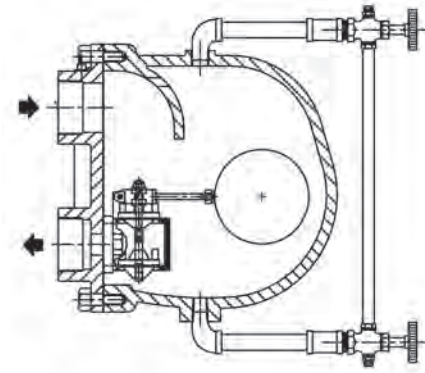

Note: WLDE and WLDES available with optional sight glass; Consult factory.

Typical Applications

The **WLDE/WLDES Series** high-capacity condensate drainers meet the flow requirements that are typically found in heavy industrial process applications for air and other gases.

How It Works

The WLDE/WLDES Series liquid drainers contain a float-operated valve. When liquid enters the drainer, the float rises opening the valve which allows liquid to be drained.

Features

- Ductile Iron or Cast Steel body and cover
- All stainless steel internals for long service life
- High capacity liquid removal
- Rugged construction design for heavy industrial use
- In-line repairable

Sample Specification

The liquid drain trap shall be float operated with a ductile iron or cast steel body and all stainless steel internals. The unit shall be in-line repairable and equipped with a FNPT threaded connection for the use of a balance line.

Installation

The installation should include isolation valves to facilitate maintenance and an in-line strainer. The trap must be level and upright for the float mechanism to operate. Trap must be adequately sized and properly located in the system. Installation may require an equalizing or balancing line connected from top of drainer body to the above piping, for proper drainage.

Maintenance

All working components can be replaced with the drain trap remaining in the pipeline. Repair kits include float, valve seat & disc and gaskets. For full maintenance details see Installation and Maintenance Manual.

MATERIALS

Body & Cover	WLDE - Ductile Iron WLDES - Cast Steel
Cover Screw	Carbon Steel, Gr 5
Cover Gasket	Garlock
Valve Discs	Stainless Steel, AISI 303
Main Valve Assembly Housing	Stainless Steel, AISI 304
Valve Assembly Gasket	Garlock
Ball Float	Stainless Steel, AISI 304
All other components	Stainless Steel

Liquid Drainers

Float Type Liquid Drainer

WLDE/WLDES Series

Float Type

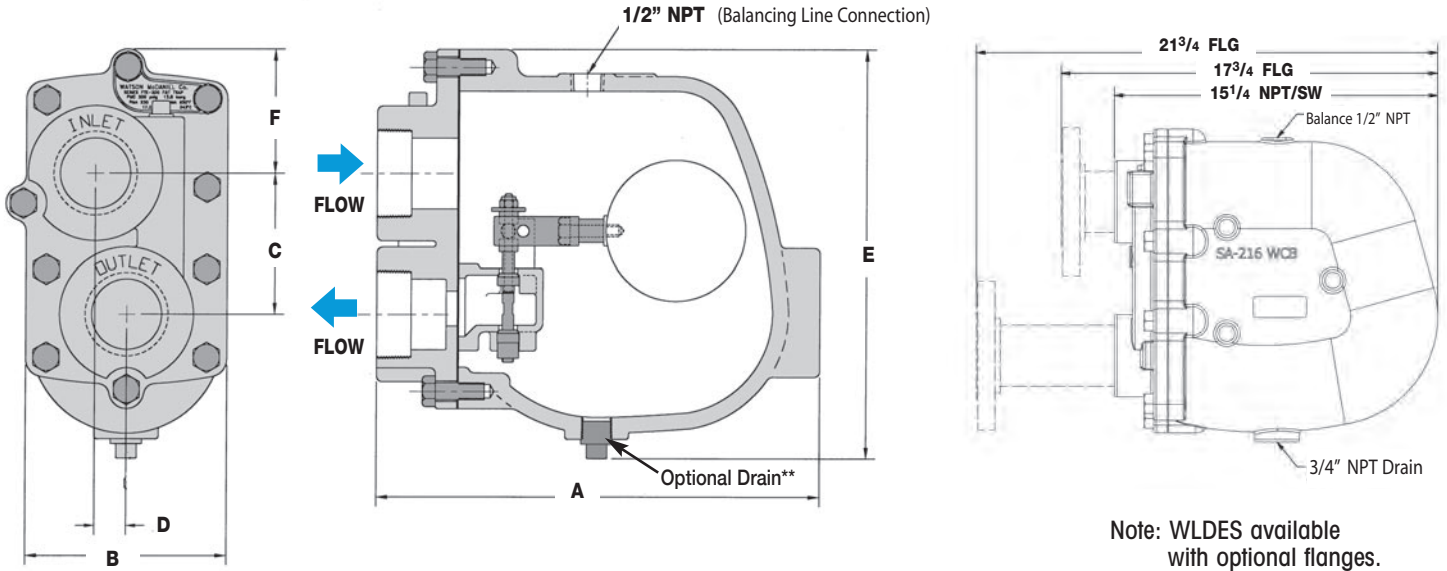

Note: WLDES available with optional flanges.

**Optional Drain:
 1 1/2" WLDE-200: 3/8" NPT
 2" WLDE-20, 200: 3/8" NPT
 2" WLDE-50: 3/4" NPT
 2 1/2" WLDE-50,125,200: 3/4" NPT
 2 1/2" WLDES: 3/4" NPT

DIMENSIONS & WEIGHTS – inches									
Model	PMO (PSIG)	Pipe Size	A	B	C	D	E	F	Weight (lbs)
WLDE	200	1 1/2"	9 1/8	4 5/16	3	11/16	8 13/16	2 1/8	24
WLDE	20	2"	12 1/8	5 11/16	4 1/2	1/2	11 1/8	3 15/16	61
WLDE	200	2"	16	8 7/16	7 5/16	17/16	15 1/8	3 1/8	150
WLDE	50	2"	15 1/2	8 7/16	7 5/16	17/16	15 1/8	3 1/8	150
WLDE	125	2 1/2"	15 1/2	8 7/16	7 5/16	17/16	15 1/8	3 1/8	150
WLDE	200	2 1/2"	15 1/2	8 7/16	7 5/16	17/16	15 1/8	3 1/8	150
WLDES	300*	2 1/2"	15 1/2	8 7/16	7 5/16	17/16	15 1/8	3 1/8	150

* Note: All WLDES models have same dimensions.

How to Size / Order

Determine the capacity (lbs/hr) required at the specified differential pressure. Locate differential pressure on capacity chart; move down column to capacity required. Make sure to select the correct model based on the maximum inlet pressure.

Example:

Required to drain 80,000 lbs/hr at a differential pressure of 5 PSI. The maximum inlet pressure is 100 PSIG.

Select Model: **WLDE-125-18-N, 2 1/2"**, capacity up to 87,294 lbs/hr based on 5 PSI differential pressure. PMO = 125 PSI

Capacity in lbs/hr is based on differential pressure across the drainer. Select a model with an equal or higher PMO (max. operating pressure) than the maximum inlet pressure to the drainer. If the pressure to the drainer exceeds the PMO, the drainer may not open. If discharging to atmosphere, the differential pressure is equal to the inlet pressure.

CAPACITIES – Cold Water (lbs/hr)

Model Code / PMO* (PSIG)	Pipe Size	Orifice Size	Differential Pressure (PSI)															
			1/4	1/2	1	2	5	10	20	40	50	75	100	125	200	300		
WLDE-20-17-N	2"	.937"	3929	5556	7858	11113	17571	24849	35141									
WLDE-50-17-N	2"	2.125"	12248	18153	25312	37751	62218	90068	123365	161302	176522							
WLDE-50-18-N	2 1/2"	2.125"	19520	27605	39039	55209	87294	123452	174588	246904	276047							
WLDE-125-18-N	2 1/2"	2.125"	19520	27605	39039	55209	87294	123452	174588	246904	276047	338088	390390	436469				
WLDE-200-16-N	1 1/2"	.375"	1051	1486	2102	2973	4700	6647	9401	13295	14864	18205	21021	23502	29728			
WLDE-200-17-N	2"	.75"	3403	4813	6807	9626	15220	21525	30441	43050	48131	58949	68068	76102	96263			
WLDE-200-18-N	2 1/2"	1.5"	11100	15713	22200	31427	49690	70273	99381	140546	157135	192450	222200	248452	314269			
WLDES-50-18-N	2 1/2"	2.125"	19520	27605	39039	55209	87294	123452	174588	246904	276047							
WLDES-125-18-N	2 1/2"	2.125"	19520	27605	39039	55209	87294	123452	174588	246904	276047	338088	390390	436469				
WLDES-200-18-N	2 1/2"	1.5"	11100	15713	22200	31427	49690	70273	99381	140546	157135	192450	222200	248452	314269			
WLDES-300-18-N	2 1/2"	1.5"	11100	15713	22200	31427	49690	70273	99381	140546	157135	192450	222200	248452	314269	427024		

* PMO based on a liquid with a specific gravity of 1.0. Consult factory for the PMO of a liquid with specific gravity less than 1.0.

LIQUID DRAINERS

Liquid Drainers

Float Type Liquid Drainer

WLD600 • Carbon Steel
WLD601 • 316 SS

Model	WLD600 & WLD601
Sizes	3/4", 1", 1 1/2", 2", 3", 4"
Connections	NPT, SW, Flanged
Body Material WLD600	Carbon Steel
Body Material WLD601	316 Stainless Steel
PMO Max. Operating Pressure	450 PSIG
TMO Max. Operating Temperature	750°F
PMA Max. Allowable Pressure	* 990 PSIG @ 100°F
TMA Max. Allowable Temperature	* 750°F @ 670 PSIG

* **3/4"- 2" only.**

Note: For dimensions and capacities of 3" & 4" liquid drain traps, refer to model FT600 in the Steam Trap section.

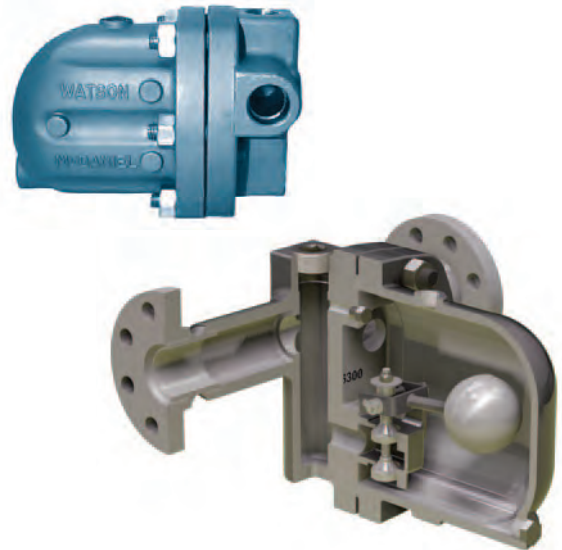

Typical Applications

The **WLD600/WLD601 Series** are used in applications where immediate and continuous discharge of large amounts of liquid is required. Typically used in heavy industrial process applications for draining condensate from air or other gases.

How It Works

The **WLD600/WLD601 Series** liquid drainers contain a float-operated valve. When liquid enters the drainer, the float rises opening the valve which allows liquid to be drained.

Features

- All stainless steel internals for long service life
- Body & cover available in Carbon Steel or 316 SS
- Rugged construction designed for heavy industrial applications
- In-line repairable

Sample Specification

The liquid drain trap shall be float operated with a cast steel body (or stainless steel body for WLD601) and all stainless steel internals. The unit shall be in-line repairable and equipped with a FNPT threaded connection for the use of a balance line.

Installation

The installation should include isolation valves to facilitate maintenance and an in-line strainer. The trap must be level and upright for the float mechanism to operate. Trap must be adequately sized and properly located in the system. Installation may require an equalizing or balancing line connected from top of drainer body to the above piping, for proper drainage.

Maintenance

All working components can be replaced with the drain trap remaining in the pipeline. Repair kits include float, valve seat & disc and gaskets. For full maintenance details see Installation and Maintenance Manual.

Options

316 SS Body & Cover: use Model **WLD601**.

MATERIALS

Body & Cover WLD600	Cast Steel, ASTM A-216 WCB
Body & Cover WLD601	Cast 316 SS
Cover Studs	Steel, SA 193, Gr B7
Cover Nuts	Steel, SA 194, Gr 2H
Cover Gasket	Stainless Steel Reinforced Grafoil
Valve Assembly	Stainless Steel, AISI 431
Gasket, Valve Assembly	Stainless Steel Reinforced Grafoil
Pivot Assembly	Stainless Steel, 17-4 PH
Mounting Screws	Stainless Steel Hex Head, 18-8
Float	Stainless Steel, ASTM 240 TY 304

How to Size / Order

Determine the capacity (lbs/hr) required at the specified differential pressure. Locate differential pressure on capacity chart; move down column to capacity required. Make sure to select the correct model based on the maximum inlet pressure.

Example:

Required to drain 2,000 lbs/hr at a differential pressure of 300 PSI. The maximum inlet pressure is 325 PSIG.

Select Model: **WLD600-450-14-N**, 1" NPT, capacity up to 2,250 lbs/hr based on 300 PSI differential pressure

Connections: (**N**=NPT, **SW**=Socket Weld, **F150**=150# FLG, **F300**=300# FLG, **F600**=600# FLG)

Example Models: **WLD600-450-14-SW** = 1" Socket Weld
WLD600-450-14-F600 = 1" 600# FLG

Liquid Drainers

Float Type Liquid Drainer

WLD600 • Carbon Steel
WLD601 • 316 SS

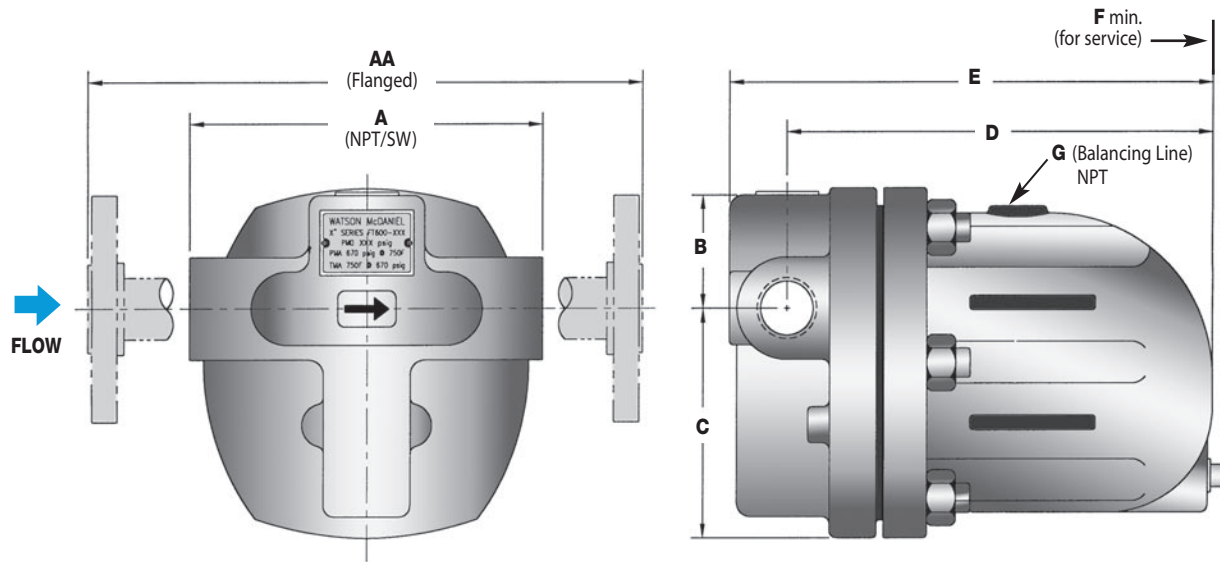

DIMENSIONS & WEIGHTS – inches/pounds										
Size	A	AA	B	C	D	E	F	G *	Weight (lbs)	
									NPT/SW	FLG
3/4"	6 1/8	10 1/8	2 1/8	37/16	77/16	87/16	5 13/16	3/8	25	31
1"	6 1/2	10 7/16	2 1/2	5 1/2	87/16	9 1/2	6 5/16	3/8	31	36
1 1/2"	9 13/16	14	3 7/16	9	10 7/16	11 15/16	7 13/16	1/2	82	91
2"	11 13/16	16	3 1/8	7 7/16	11 1/8	13 5/16	6 13/16	1/2	93	107

* Balancing Port available with 1/2" flanged connection. Specify on order.

Capacity in lbs/hr is based on differential pressure across the drainer. Select a model with an equal or higher PMO (max. operating pressure) than the maximum inlet pressure to the drainer. If the pressure to the drainer exceeds the PMO, the drainer may not open. If discharging to atmosphere, the differential pressure is equal to the inlet pressure.

CAPACITIES – Cold Water (lbs/hr)			For WLD600 & WLD601														
Model Code PMO* (PSIG)	Pipe Size	Orifice Size	Differential Pressure (PSI)														
			2	5	10	20	30	40	65	70	80	100	145	200	300	350	450
WLD600-65-13-N	3/4"	.156	340	520	730	1010	1220	1440	1770								
WLD600-65-14-N	1"	.276	1390	2140	2970	4130	5000	5730	7210								
WLD600-65-16-N	1 1/2"	.689	4160	6430	8920	12380	15000	17190	21630								
WLD600-65-17-N	2"	1.122	14730	22720	31540	43790	53060	60790	76500								
WLD600-145-13-N	3/4"	.126	210	320	450	620	760	870	1090	1130	1200	1340	1590				
WLD600-145-14-N	1"	.205	690	1070	1490	2060	2500	2870	3610	3740	3980	4420	5270				
WLD600-145-16-N	1 1/2"	.591	2360	3630	5050	7010	8490	9730	12240	12670	13500	15000	17890				
WLD600-145-17-N	2"	.807	5840	9010	12510	17370	21040	24110	30340	31420	33470	37200	44360				
WLD600-200-13-N	3/4"	.106	170	260	360	500	600	690	870	900	960	1060	1270	1480			
WLD600-200-14-N	1"	.185	450	690	960	1330	1620	1850	2330	2410	2570	2860	3410	3970			
WLD600-200-16-N	1 1/2"	.531	1650	2550	3540	4910	5950	6820	8580	8890	9470	10520	12540	14610			
WLD600-200-17-N	2"	.657	2890	4460	6190	8590	10410	11930	15010	15540	16560	18400	21940	25540			
WLD600-300-13-N	3/4"	.079	80	130	180	250	300	340	430	450	480	530	630	730	890		
WLD600-300-14-N	1"	.156	340	520	730	1010	1220	1400	1770	1830	1950	2160	2580	3010	3640		
WLD600-300-16-N	1 1/2"	.531	1650	2550	3540	4910	5950	6820	8580	8890	9470	10520	12540	14610	17700		
WLD600-300-17-N	2"	.657	2890	4460	6190	8590	10410	11930	15010	15540	16560	18400	21940	25540	30950		
WLD600-450-13-N	3/4"	.063	50	70	100	140	160	190	240	250	260	290	350	400	490	530	590
WLD600-450-14-N	1"	.126	210	320	450	620	760	870	1090	1130	1200	1340	1590	1860	2250	2420	2720
WLD600-450-16-N	1 1/2"	.531	1650	2550	3540	4910	5950	6820	8580	8890	9470	10520	12540	14610	17700	19040	21440
WLD600-450-17-N	2"	.657	2890	4460	6190	8590	10410	11930	15010	15540	16560	18400	21940	25540	30950	33290	37490

* PMO based on a liquid with a specific gravity of 1.0. Consult factory for the PMO of a liquid with specific gravity less than 1.0.

Liquid Drainers

Guided Float Type Liquid Drainer

WLD1800/1800R Series

Guided Float Type

Model	WLD1800 Non-repairable WLD1800R Repairable
Sizes	1/2", 3/4"
Connections	NPT
Body Material	Stainless Steel
PMO Max. Operating Pressure	400 PSIG
TMO Max. Operating Temperature	500°F
PMA Max. Allowable Pressure	400 PSIG @ 500°F
TMA Max. Allowable Temperature	500°F @ 400 PSIG



WLD1800
(Non-Repairable)



WLD1800R
(Repairable)

Typical Applications

The **WLD1800/1800R Series** are used on industrial air and gas applications for drainage of liquid from systems.

How It Works

The WLD1800 Series liquid drainers contain a float-operated valve. When liquid enters the drainer, the float rises opening the valve which allows liquid to be drained.

Features

- **Stainless steel body**
- **All stainless steel internals for longer service life**
- **Guided float ensures proper valve seating on every cycle**
- **Repairable unit available (WLD1800R)**

Sample Specification

The liquid drain trap shall have a guided-float operation with a tamper-proof seal-welded stainless steel body and all stainless steel internals. The unit shall be available with an in-line repairable version. All units to be equipped with FNPT threaded end connections.

Installation

The installation should include an in-line strainer. The trap must be level and upright for the float mechanism to operate. Trap must be adequately sized and properly located in the system.

Maintenance

The WLD1800 is non-repairable. The WLD1800R is fully repairable and all working components can be replaced. Repair kits include float, lever & seat assembly, and gaskets. For full maintenance details see Installation and Maintenance Manual.

MATERIALS

Body	Stainless Steel, AISI 304
Inlet & Outlet Fittings	Stainless Steel, AISI 304
Float Assembly	Stainless Steel, AISI 304
Valve & Lever Assembly	Stainless Steel, AISI 303
Seat	Hardened Stainless Steel
*Gasket (Repairable only)	Grafoil
Washer, Seat	302 Stainless Steel
*Bolt, Hex, HD	Stainless Steel, AISI 316
*Nut, Jam	Stainless Steel, 18-8

* WLD1800R repairable models only.

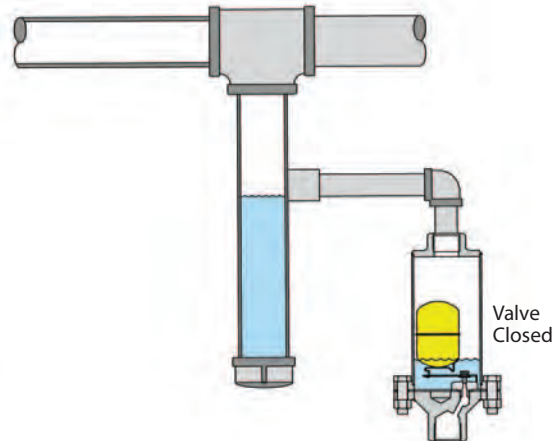
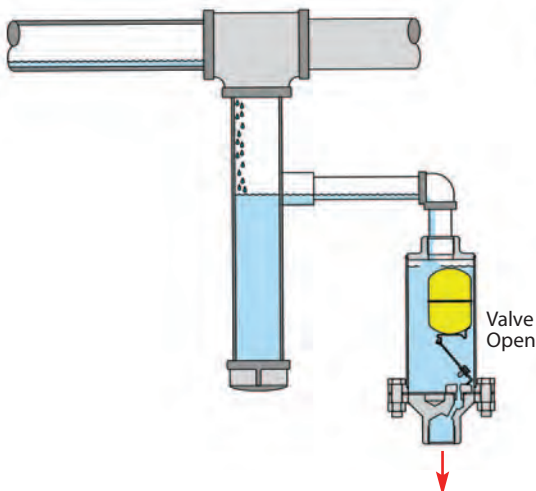

Liquid Drainers

Guided Float Type Liquid Drainer

WLD1800/1800R Series

Guided Float Type

WLD1800 - Non-Repairable

Weight: 4 lbs

Connection Inlet x Outlet	Model Code	PMO PSI	Orifice Size
3/4" x 1/2"	WLD1811-N	400	.078"
3/4" x 3/4"	WLD1812-N	400	.078"
1/2" x 1/2"	WLD1813-N	400	.078"
3/4" x 1/2"	WLD1821-N	255	.101"
3/4" x 3/4"	WLD1822-N	255	.101"
1/2" x 1/2"	WLD1823-N	255	.101"
3/4" x 1/2"	WLD1831-N	175	.125"
3/4" x 3/4"	WLD1832-N	175	.125"
1/2" x 1/2"	WLD1833-N	175	.125"

WLD1800R - Repairable

Weight: 5 lbs

Connection Inlet x Outlet	Full Model Code	PMO PSI	Orifice Size
3/4" x 1/2"	WLD1811R-N	400	.078"
3/4" x 3/4"	WLD1812R-N	400	.078"
1/2" x 1/2"	WLD1813R-N	400	.078"
3/4" x 1/2"	WLD1821R-N	255	.101"
3/4" x 3/4"	WLD1822R-N	255	.101"
1/2" x 1/2"	WLD1823R-N	255	.101"
3/4" x 1/2"	WLD1831R-N	175	.125"
3/4" x 3/4"	WLD1832R-N	175	.125"
1/2" x 1/2"	WLD1833R-N	175	.125"

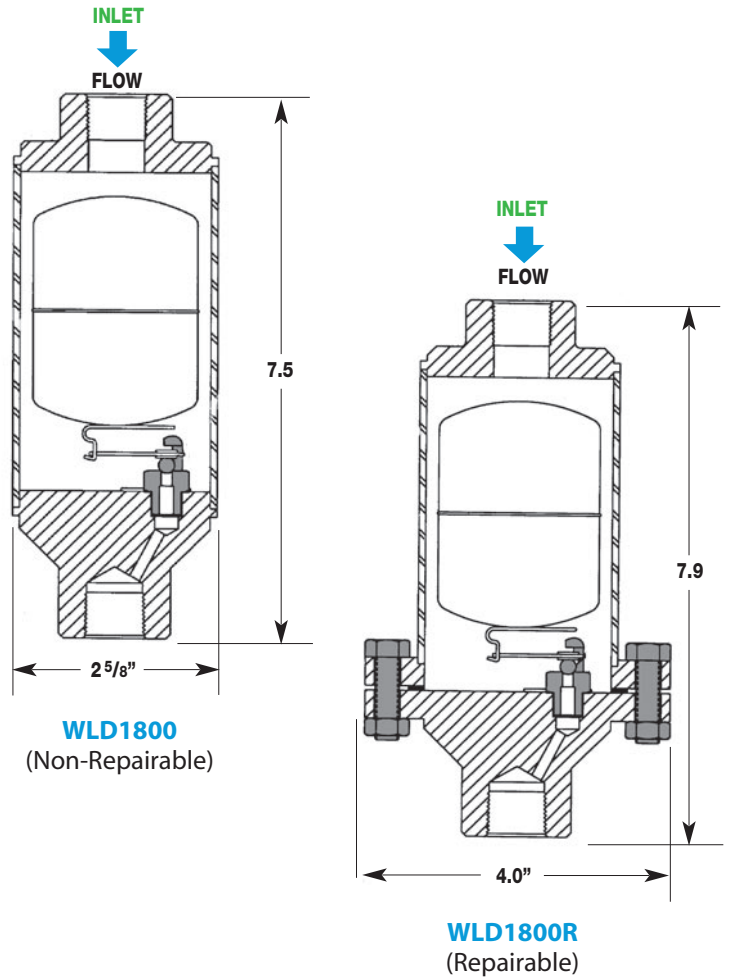

LIQUID DRAINERS

How to Size / Order

Determine the capacity (lbs/hr) required at the specified differential pressure. Locate differential pressure on capacity chart; move down column to capacity required. Make sure to select the correct model based on the maximum inlet pressure.

Example: Required to drain 1,000 lbs/hr at a differential pressure of 200 PSI. The maximum inlet pressure is 250 PSIG.

Select Model: **WLD1822-N** 3/4" x 3/4" (non-repairable) or **WLD1822R-N** 3/4" x 3/4" (repairable); capacity up to 1,200 lbs/hr based on 200 PSI differential pressure.

CAPACITIES – Cold Water (lbs/hr)		Differential Pressure (PSI)																	
Series	PMO* (PSIG)	Orifice Size	1	2	5	10	15	20	30	50	100	150	175	200	250	275	300	350	400
WLD1810	400	.078"	60	80	120	130	180	260	315	400	570	700	750	800	900	940	1050	1050	1120
WLD1820	255	.101"	90	120	175	195	275	385	470	610	860	1050	1125	1200	1350	1425			
WLD1830	175	.125"	160	230	325	365	510	730	790	1150	1630	2000	2150						

* PMO based on a liquid with a specific gravity of 1.0. Consult factory for the PMO of a liquid with specific gravity less than 1.0.

CAPACITY CORRECTION FACTORS																			
Specific Gravity		1	.98	.96	.94	.92	.90	.88	.86	.84	.82	.80	.75	.70	.65	.60	.55	.50	
Correction Factor		1	.99	.98	.97	.959	.949	.938	.927	.917	.906	.894	.866	.837	.806	.775	.742	.707	

Note: To obtain capacity with a liquid other than water, multiply water capacity by correction factor.

Liquid Drainers

Inverted Bucket Type Liquid Drainer

WLD1500 Series

Inverted Bucket Type

Model	WLD1501, WLD1502, WLD1504, WLD1521, WLD1522, WLD1524
Sizes	3/4", 1"
Connections	NPT
Body Material	Cast Iron
PMO Max. Operating Pressure	200 PSIG
TMO Max. Operating Temperature	450°F
PMA Max. Allowable Pressure	250 PSIG up to 450°F
TMA Max. Allowable Temperature	450°F @ 250 PSIG



WLD1521/1522/1524
with Strainer

Typical Applications

The **WLD1500 Series** Inverted Bucket Liquid Drain Traps are recommended for the removal of liquids from compressed air systems. A scrubber wire is used to keep bleed hole on top of inverted bucket from clogging due to oil that may be present in the water being drained. Oil mixed with water is typically found on compressed air systems.

How It Works

When there is condensate in the system, the inverted bucket inside the liquid drain trap rests on the bottom due to its weight; with the valve in the open position. This allows liquid entering the trap to be discharged through the seat orifice located at the top. When air enters the trap, the bucket floats to the surface and closes off the discharge valve, containing the air in the system. Eventually, air is bled off through a small hole in the top of the bucket and the bucket sinks; repeating the cycle.

Features

- Hardened stainless steel valves and seat
- Only two moving parts
- Scrubber wire in air vent of bucket
- Discharge orifice at top of trap reduces potential for clogging
- In-line repairable

Sample Specification

Drain trap shall be an inverted bucket trap design with cast iron body, all stainless steel internals, hardened valve & seat, plus a scrubber wire. The unit shall be in-line repairable.

Installation

Installation should include isolation valves for maintenance purposes. Trap must be installed in upright position to function properly. It may be necessary to prime the bucket trap by filling it with water through the priming port prior to startup.

Maintenance

Close isolation valves prior to any maintenance. All working components can be replaced with the drain trap remaining in the pipeline. Repair kits include lever & seat assembly, strainer screen and gaskets. For full maintenance details see Installation and Maintenance Manual.

MATERIALS

Body & Cover	Cast Iron, ASTM A-278 Class 30
Nuts & Bolts	High-Tensile Steel
Gasket	Non-Asbestos Fiber
Bucket	Stainless Steel
Scrubber	Stainless Steel
Lever & Seat Assembly	Stainless Steel
Valve & Seat	Hardened Stainless Steel
Integral Strainer*	Stainless Steel

* WLD1521, WLD1522 & WLD1524 models only.

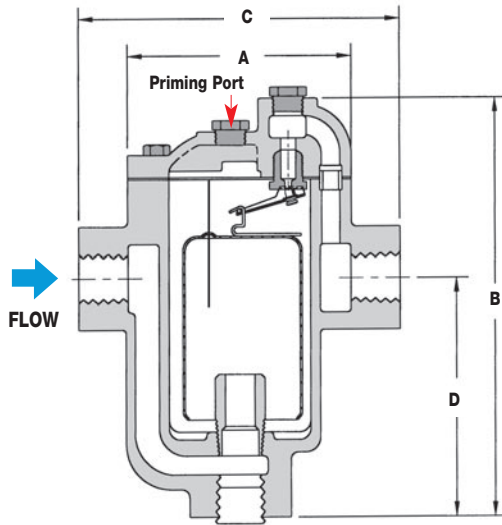

WLD1501/1502/1504

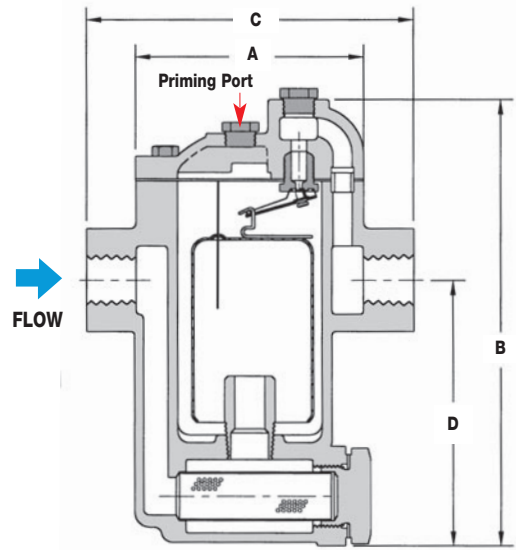

WLD1521/1522/1524
with Strainer

DIMENSIONS & WEIGHTS – inches / pounds						
Model	Size	A	B	C	D	Weight
WLD1501-13-N	3/4"	3 ¹³ / ₁₆	5 ⁷ / ₁₆	5	2 ¹³ / ₁₆	5
WLD1502-13-N	3/4"	3 ¹³ / ₁₆	6 ¹⁵ / ₁₆	5	4 ⁵ / ₁₆	6
WLD1504-14-N	1"	7	11 ¹³ / ₁₆	7 ¹³ / ₁₆	7	27
WLD1521-13-N	3/4"	3 ¹³ / ₁₆	6 ¹ / ₈	5	3 ⁷ / ₁₆	5.5
WLD1522-13-N	3/4"	3 ¹³ / ₁₆	7 ¹ / ₈	5	4 ⁷ / ₁₆	6
WLD1524-14-N	1"	7	12 ⁷ / ₁₆	7 ¹³ / ₁₆	7 ⁷ / ₁₆	30

How to Size / Order

Determine the capacity (lbs/hr) required at the specified differential pressure. Locate differential pressure on capacity chart; move down column to capacity required. Make sure to select the correct model based on the maximum inlet pressure.

Example:

Required to drain 200 lbs/hr at a differential pressure of 5 PSI. The maximum inlet pressure is 30 PSIG.

Select Model: **WLD1521-13-N**, 3/4" NPT, with strainer, capacity up to 220 lbs/hr based on 5 PSI differential pressure.

Capacity in lbs/hr is based on differential pressure across the drainer. Select a model with an equal or higher PMO (max. operating pressure) than the maximum inlet pressure to the drainer. If the pressure to the drainer exceeds the PMO, the drainer may not open. If discharging to atmosphere, the differential pressure is equal to the inlet pressure.

CAPACITIES – Cold Water (lbs/hr)													
Model Code	PMO* (PSIG)	Size	Differential Pressure (PSI)										
			2	5	10	25	50	80	100	125	150	180	200
WLD1501-13-N	150	3/4"	145	220	325	510	720	900	1010	1130	1215		
WLD1502-13-N	200	3/4"	170	260	380	595	835	1045	1175	1315	1410	1550	1645
WLD1504-14-N	200	1"	500	760	1105	1740	2460	3065	3450	3865	4140	4555	4835

* PMO based on a liquid with a specific gravity of 1.0. Consult factory for the PMO of a liquid with specific gravity less than 1.0.

LIQUID DRAINERS

Model	WLD1703S
Sizes	1/2"
Connections	NPT
Body Material	Stainless Steel
Options	Blowdown Valve
PMO Max. Operating Pressure	250 PSIG
TMO Max. Operating Temperature	750°F
PMA Max. Allowable Pressure	915 PSIG up to 250°F
TMA Max. Allowable Temperature	610°F @ 750 PSIG



WLD1703SB
with Strainer
& Blowdown
Valve

WLD1703S
with Strainer

WLD1703SB
with Strainer &
Blowdown
Valve

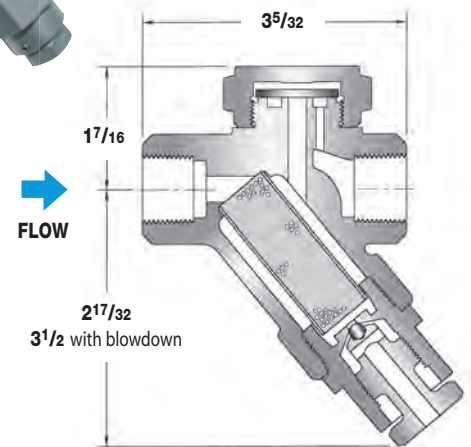

Units: inches

Typical Applications

The **WLD1703S** is used on air and gas applications as drip traps on system mains and other piping runs. These drain traps are ideal for outdoor applications where units are subject to freezing.

How It Works

The disc type liquid drain trap has a cyclic on/off operation with a disc that is pushed open when condensate is present and pulled closed when air or gas tries to escape.

Features

- Rugged, stainless steel body and hardened seat
- Handles a wide range of pressures up to 250 PSIG
- Works in any position (horizontal preferable)
- Integral strainer with blowdown option
- Three-holed balanced discharge
- Freeze-proof in vertical flow-down position

Sample Specification

Drain Trap shall be a Disc Type with an all stainless steel construction. Body shall have a built-in strainer with optional blowdown valve. Integral seat design and disc to be hardened for long service life. Unit shall be capable of installation in any orientation and self-draining when mounted vertically with flow direction downwards.

Installation

Drain Trap can be installed in any position; however, horizontal is preferred. Installation should include isolation valves for maintenance purposes.

Maintenance

Dirt is the most common cause of premature failure. The strainer may require periodic cleaning. For full maintenance details see Installation and Maintenance Manual.

Options

Blowdown valve allows strainer to be cleaned without removal.

MATERIALS

Body	Stainless Steel, AISI 420F
Disc	Stainless Steel, AISI 420
Cap	Stainless Steel, AISI 416
Strainer Screen	Stainless Steel, AISI 304
Blowdown Valve*	Stainless Steel, AISI 303

* WLD1703SB model only.

CAPACITIES – Cold Water (lbs/hr)

Model Code	Description	Pipe Size	Inlet Pressure (PSIG)												
			2	5	10	25	50	80	100	125	150	180	200	250	
WLD1703S-12-N	Strainer	1/2"	90	130	190	300	425	530	600	670	715	790	835	955	
WLD1703SB-12-N	Strainer & Blowdown		90	130	190	300	425	530	600	670	715	790	835	955	

Note: 1) Maximum back pressure not to exceed 80% of inlet pressure.

2) To determine gallons per minute of flow, divide values in chart by 500. Example: 600 lbs/hr = 600 ÷ 500 = 1.2 GPM