

KAMMAC

KAMMAC V Series Rack and Pinion Pneumatic Actuators



Features and Benefits

- Extruded Aluminum Body with hard anodized finish, polyester powder coated / Epoxy, PTFE or Niplated. Standard internal polished surfaces.
- Die Cast Aluminum End Caps powder polyester paint, PTFE or nickel plated.
- Position Indicator with NAMUR slot for ease of accessory mounting
- High Precision Nickel Alloy Steel Blow-out Proof Pinion provides corrosion protection and fully conforms to ISO 5211 and NAMUR standards.
- Dual Opposed Rack Pistons with low friction bearings and guides for high performance, long cycle life and fast response. Pistons can be easily inverted for reversing rotation.
- Independent Travel Stop Adjustments of $\pm 5^\circ$ in both open and closed positions for precise valve alignment.

- Linear Torque Output from 0° through 90° stroke.
- High Performance Pre-loaded Spring Cartridges allow for greater safety and longer spring life. Double acting units can be easily converted to spring return by adding the appropriate quantity of cartridges. Different torque requirements can also be easily achieved by changing the quantity of springs.
- NAMUR Solenoid Mounting Design permits direct mounting of solenoid valves.
- Stainless Steel 304 Fasteners as standard
- High Quality O-rings provides trouble-free operation for a wide range of temperature applications.
- Optional Corrosion Protection available for body and end caps.

Operating Conditions

Operating Media:

Dry and lubricated air, or non-corrosive gas. The maximum particle diameter must be less than 30 μm . Optional units shall be able to operate with other media such as hydraulic oil or purified water. Consult factory for further information.

Stroke Adjustment:

Stops allow adjustment range of plus/minus 5°F for the rotation at 0° and 90° position.

Air Supply Pressure:

The minimum supply pressure is 35 psig. The maximum supply pressure is 150 psig.

Operating Temperature:

Standard (NBR O-ring): -4°F to 175°F .
Low Temperature (LNBR O-ring): -30°F to 175°F .
High Temperature (Viton O-ring): 5°F to 300°F .

Application:

All types of ball, butterfly, and plug valves both indoor and outdoor.

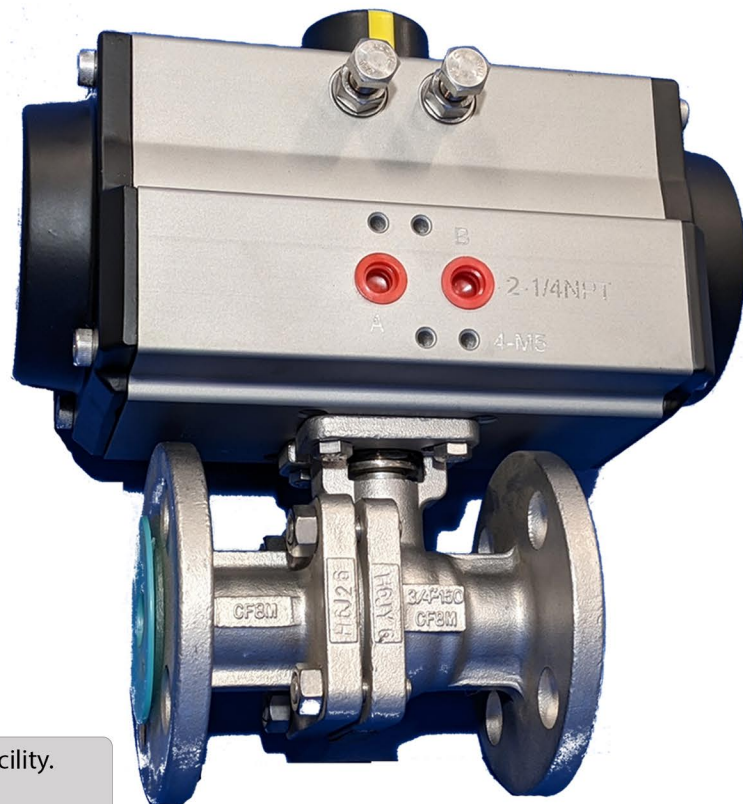

Quality Assurance

- All actuators are manufactured in a registered ISO 9001-2000 facility.
- All actuators are CE certified.
- All actuators are 100% inspected and factory tested.
- Each actuator is marked with a unique serial number for full traceability.
- KAMMAC can also provide valve automation accessories, including Limit Switches, Positioners, Solenoid Valves, and Mounting Hardware.

Materials

Exploded View

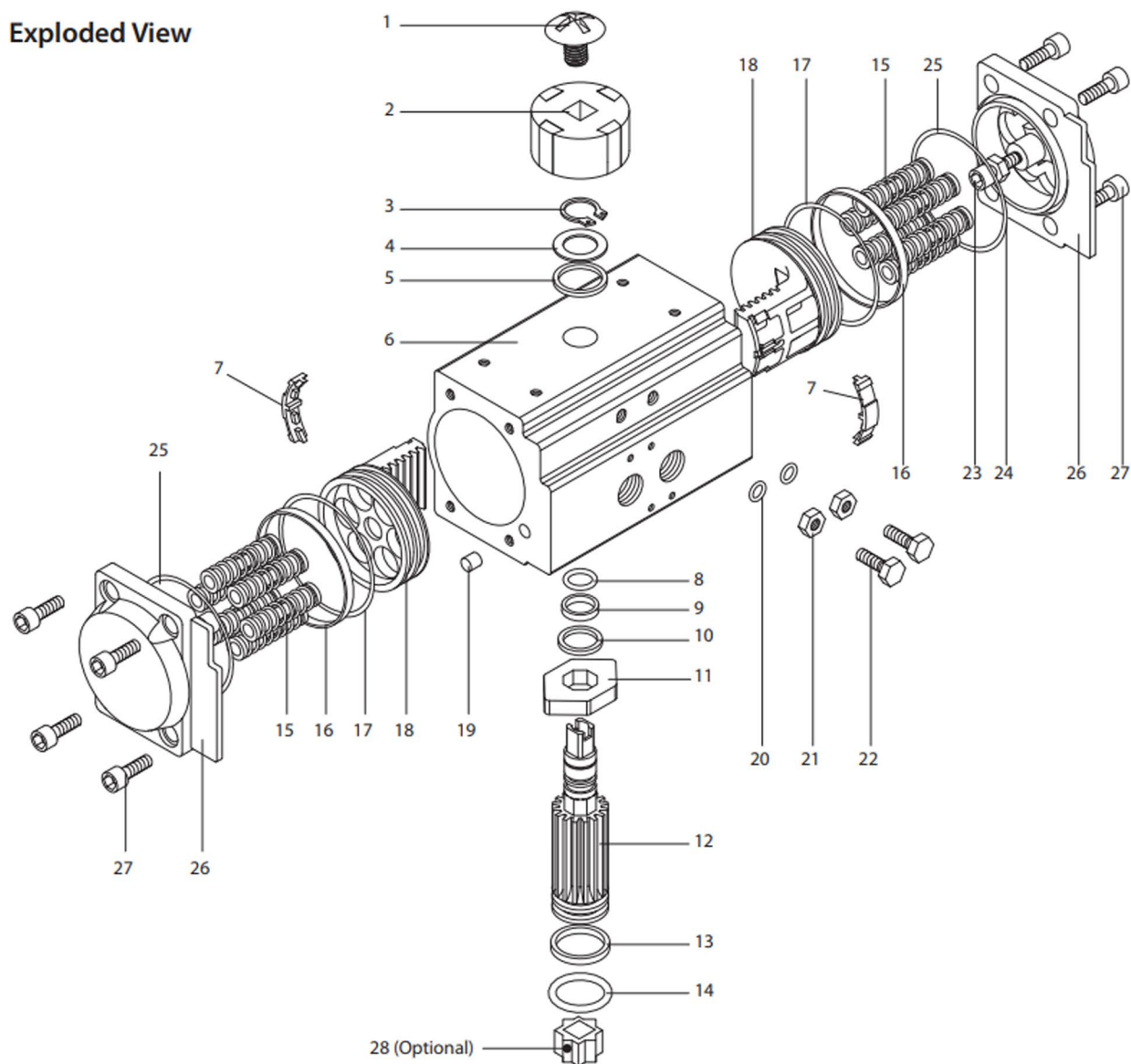

No.	Part Description	Qty.	Material	No.	Description	Qty.	Material
1	Indicator Cap Screw	1	Plastic / Stainless Steel	15	Spring (Cartridge)	0-12	High Alloy Spring Steel
2	Position Indicator	1	Plastic (ABS)	16	Bearing (Piston)	2	Polyoxymethylene (Delrin)
3	Pinion Snap Ring	1	Stainless Steel 300 Series	17	O-ring (Piston)	2	NBR / Buna
4	Thrust Washer	1	Stainless Steel 300 Series	18	Piston	2	Die-Casting Aluminum
5	Thrust Bearing	1	Polyoxymethylene (Delrin)	19	Plug	2	NBR / Buna
6	Body	1	Extruded Aluminum Alloy	20	O-ring (Adjust Screw)	2	NBR / Buna
7	Piston Guide	2	Polyoxymethylene (Delrin)	21	Stop Nut (Adjust Screw)	2	Stainless Steel 300 Series
8	O-ring (Pinion Top)	1	NBR / Buna	22	Adjust Screw	2	Stainless Steel 300 Series
9	Bearing (Pinion Top)	1	Polyoxymethylene (Delrin)	23	Stop Screw	2	Stainless Steel 300 Series
10	Inside Washer	1	Polyoxymethylene (Delrin)	24	Nut (Stop Screw)	2	Stainless Steel 300 Series
11	Cam	1	Alloy Steel *	25	O-ring (End Cap)	2	NBR / Buna
12	Pinion (Drive Shaft)	1	S.S. 300 Series / Nickel Plated Alloy *	26	End Cap	2	Die-Casting Aluminum
13	Bearing (Pinion Bottom)	1	Polyoxymethylene (Delrin)	27	End Cap Screw	8	Stainless Steel 300 Series
14	O-ring (Pinion Bottom)	1	NBR / Buna	28	Shaft Adapter	1	Sintered Metal

Dimensions

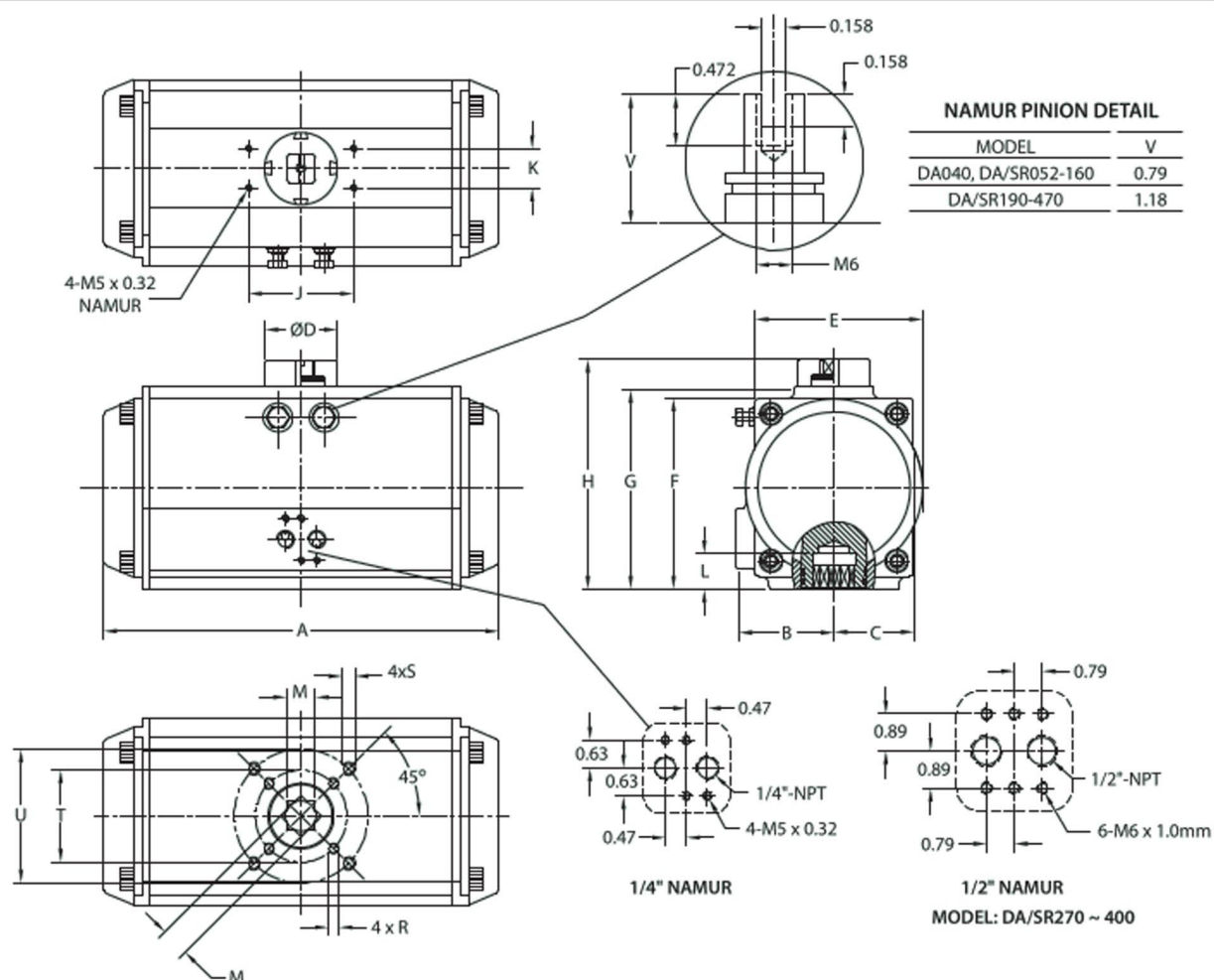

Unit: Inch

Model	A	B	C	D	E	F	G	H	J	K	L	M	R	S	T	U
DA040	4.81	1.13	1.44	1.58	2.05	2.36		3.15	3.15	1.18	0.55	0.43	M5 x 8	M6 x 10	F03/1.417	F05/1.969
DA/SR052	5.79	1.18	1.63	1.58	2.56	2.58	2.83	3.62	3.15	1.18	0.55	0.43	M5 x 8	M6 x 10	F03/1.417	F05/1.969
DA/SR063	6.61	1.42	1.85	1.58	2.83	3.19	3.44	4.23	3.15	1.18	0.71	0.55	M6 x 10	M8 x 13	F05/1.969	F07/2.756
DA/SR075	7.24	1.65	2.09	1.58	3.19	3.7	3.92	4.7	3.15	1.18	0.71	0.55	M6 x 10	M8 x 13	F05/1.969	F07/2.756
DA/SR083	8.03	1.81	2.24	1.58	3.62	3.88	4.28	5.07	3.15	1.18	0.83	0.67	M6 x 10	M8 x 13	F05/1.969	F07/2.756
DA/SR092	10.31	1.97	2.3	1.58	3.86	4.37	4.6	5.39	3.15	1.18	0.83	0.67	M6 x 10	M8 x 13	F05/1.969	F07/2.756
DA/SR105	10.55	2.26	2.52	1.58	4.31	4.82	5.24	6.02	3.15	1.18	1.02	0.87	M8 x 13	M10 x 16	F07/2.756	F10/4.016
DA/SR125	11.85	2.66	2.93	2.17	5.02	5.73	6.1	6.89	3.15	1.18	1.02	0.87	M8 x 13	M10 x 16	F07/2.756	F10/4.016
DA/SR140	15.35	2.95	3.03	2.17	5.41	6.33	6.75	7.54	3.15	1.18	1.22	1.06	M10 x 16	M12 x 20	F10/4.016	F12/4.921
DA/SR160	18.03	3.43	3.43	2.17	6.22	7.24	7.76	8.54	3.15	1.18	1.22	1.06	M10 x 16	M12 x 20	F10/4.016	F12/4.921
DA/SR190	20.79	4.06	4.06	3.15	7.44	8.5	9.06	10.24	5.12	1.18	1.57	1.42	M16 x 24		F14/5.512	
DA/SR210	20.94	4.45	4.45	3.15	8.27	9.27	10.04	11.22	5.12	1.18	1.57	1.42	M16 x 24		F14/5.512	
DA/SR240	23.7	5.12	5.12	3.15	9.65	10.39	11.38	12.56	5.12	1.18	1.97	1.81	M20 x 25		F16/6.496	
DA/SR270	28.42	5.79	5.79	3.15	10.75	11.77	12.83	14.01	5.12	1.18	1.97	1.81	M20 x 25		F16/6.496	
DA/SR300	29.84	7.99	7.99	3.15	15.98	12.42	13.7	14.88	5.12	1.18	2.36	1.81	M20 x 25	M20 x 25	F16/6.496	8.465
DA/SR350	34.97	9.06	9.06	3.15	18.12	14.5	16.06	17.25	5.12	1.18	2.36	1.81	M20 x 25	M16 x 24	F16/6.496	F25/10.00
DA/SR400	36.61	10.16	10.16	3.15	20.32	17.5	18.9	20.08	5.12	1.18	2.36	2.17	M20 x 25	M16 x 24	F16/6.496	F25/10.00

Spring Return Actuator Output Torque (in-lbs)

		Output Air to Spring															
Air Pressure (PSI)		40	40	50	50	60	60	70	70	80	80	90	90	100	100	Spring	Spring
Actuator Type	SpringNo.	0° Start	90° End	0° Start	90° End	0° Start	90° End	0° Start	90° End	0° Start	90° End	0° Start	90° End	0° Start	90° End	90° Start	End
SR052	5	55	37	77	58											55	38
	6	48	24	70	46	94	78									66	45
	7	39	13	61	34	90	67	120	89							77	52
	8			53	20	84	55	113	78	140	114					87	60
	9			44	8	76	44	105	67	133	104	160	132			98	67
	10					68	33	98	57	126	94	153	122			109	75
	11					60	21	91	46	119	84	146	113	172	140	120	82
	12							83	36	112	74	139	95	166	130	131	90
SR063	5	111	75	153	116	204	137									92	61
	6	98	55	138	95	191	152	242	205							111	72
	7	84	35	127	73	179	133	229	187							129	85
	8			111	52	167	114	218	169	267	220	315	269			148	97
	9					154	95	206	151	255	203	304	253			166	109
	10					132	75	195	133	244	186	293	236	341	286	185	121
	11							184	115	234	169	283	220	330	270	203	133
	12							171	97	222	152	271	204	320	254	222	145
SR075	5	141	103	197	158	270	235									128	93
	6	121	74	176	128	251	208	321	280							154	112
	7	101	47	155	99	232	182	303	256							179	131
	8			133	69	211	155	284	231	352	301	418	369			205	149
	9					192	129	266	206	335	278	402	347			231	168
	10					174	102	246	181	318	254	386	324	451	391	256	187
	11							231	157	301	231	369	301	435	369	282	205
	12							213	132	284	207	353	278	419	346	308	224
SR083	5	227	157	317	244	428	364									204	140
	6	196	112	285	196	400	321	508	434							244	168
	7	166	67	252	151	371	279	481	395							285	196
	8			221	103	342	237	454	355	560	466	663	572			326	224
	9					313	192	426	316	534	429	638	536			367	252
	10					284	152	400	276	508	391	613	500	715	605	407	280
	11							373	237	483	353	588	464	691	570	448	308
	12							345	198	456	316	563	428	667	536	489	336
SR092	5	322	214	450	338	612	511									304	207
	6	277	148	403	269	569	449	725	612							365	248
	7	231	80	355	197	526	385	685	553							426	289
	8			319	128	484	323	646	495	799	655	947	808			487	331
	9					441	260	606	436	761	599	911	755			548	372
	10					399	197	566	377	723	543	874	700	1022	853	608	413
	11							525	318	685	487	837	647	986	801	669	454
	12							486	260	647	432	800	593	950	749	730	496
SR105	5	497	325	687	508	921	760									436	280
	6	435	229	622	407	862	670	1088	908							523	336
	7	374	133	559	308	805	580	1035	824							610	392
	8			494	208	747	490	980	740	1203	974	1419	1198			697	448
	9					689	400	927	656	1152	894	1370	1122			784	504
	10					631	306	872	569	1100	811	1320	1041	1535	1264	871	560
	11							818	487	1048	733	1270	966	1486	1191	958	616
	12							764	406	997	656	1221	892	1439	1119	1045	672
SR125	5	712	453	1000	729	1358	1115									698	462
	6	610	305	893	574	1263	976	1608	1340							832	555
	7	509	148	787	410	1167	828	1519	1202							971	647
	8			681	255	1071	689	1429	1072	1770	1429	2100	1772			1110	740
	9					976	541	1340	934	1685	1298	2018	1645			1249	832
	10					880	402	1251	804	1600	1174	1936	1526	2264	1865	1387	925
	11							1161	666	1514	1043	1854	1399	2184	1742	1530	1017
	12							1072	536	1429	919	1772	1280	2105	1626	1665	1110
SR140	5	1246	823	1737	1296	2346	1948									1143	759
	6	1082	573	1566	1035	2192	1713	2778	2331							1370	908
	7	916	324	1392	773	2035	1478	2631	2112							1598	1059
	8			1218	512	1878	1244	2485	1892	3063	2498	3624	3080			1826	1211
	9					1713	1009	2331	1673	2916	2290	3483	2879			2054	1370
	10					1557	765	2185	1446	2777	2073	3348	2670	3906	3247	2283	1522
	11							2039	1226	2638	1864	3214	2468	3776	3051	2510	1673
	12							1892	1007	2498	1655	3080	2267	3645	2855	2741	1824

Performance Cont.

Spring Return Actuator Output Torque (in-lbs)

		Output Air to Spring														Spring	Spring
Air Pressure (PSI)		40	40	50	50	60	60	70	70	80	80	90	90	100	100	90° Start	Spring
Actuator Type	SpringNo.	0° Start	90° End	0° Start	90° End	0° Start	90° End	0° Start	90° End	0° Start	90° End	0° Start	90° End	0° Start	90° End	90° Start	End
SR160	5	1877	1212	2640	1943	3592	2966									1844	1236
	6	1609	805	2359	1518	3340	2583	4256	3549							2212	1483
	7	1332	398	2069	1093	3079	2200	4012	3192							2581	1730
	8			1789	667	2826	1818	3777	2022	4680	3782	5556	4691			2949	1977
	9					2566	1435	3533	2477	4448	3442	5332	4363			3321	2225
	10					2313	1052	3297	2120	4223	3102	5116	4034	5986	4935	3691	2472
	11								3062	1771	3999	2769	4900	3714	5776	4624	4056
	12							2818	1413	3767	2429	4676	3386	5559	4305	4422	2966
SR190	5	3228	2164	4457	3345	5957	4957									2737	1774
	6	2839	1563	4051	2717	5592	4392	7041	5921							3287	2127
	7	2451	962	3645	2088	5227	3827	6700	5393							3834	2480
	8			3239	1460	4861	3261	6359	4865	7789	6366	9180	7808			4380	2833
	9					4496	2696	6018	4337	7464	5863	8867	7323			4927	3186
	10					4131	2131	5677	3809	7139	5360	8554	6838	9936	8269	5473	3540
	11								5336	3281	6814	4858	8240	6354	9632	7798	6020
	12							4995	2753	6490	4355	7927	5869	9327	7327	6566	4246
SR210	5	3801	2774	5327	4254	7227	6262									3363	2430
	6	3265	2035	4767	3481	6723	5566	8552	7472							4036	2917
	7	2728	1295	4206	2707	6218	4870	8081	6822							4708	3405
	8			3645	1934	5714	4174	7610	6172	9413	8044	11164	9844			5381	3893
	9					5209	3479	7139	5523	8965	7426	10731	9247			6053	4380
	10					4705	2783	6668	4873	8516	6807	10299	8651	12038	10436	6726	4868
	11								6197	4223	8068	6188	9866	8054	11617	9856	7399
	12							5726	3574	7619	5569	9434	7457	11197	9276	8071	5843
SR240	5	5373	3977	7571	6111	10332	9018									4902	3632
	6	4578	2895	6739	4979	9584	8001	12239	10761							5885	4355
	7	3773	1822	5898	3858	8827	6992	11533	9819							6861	5087
	8			5066	2727	8079	5975	10834	8869	13451	11579	15989	14184			7844	5810
	9					7323	4957	10128	7919	12778	10674	15340	13312			8828	6541
	10					6575	3948	9429	6976	12113	9777	14699	12446	17220	1503	9803	7264
	11								8731	6026	11448	8872	14057	11574	16596	14183	10787
	12							8024	5076	10775	7967	13408	10701	15966	13335	11771	8719
SR270	5	8786	6576	12163	9852	16289	14210									6961	4952
	6	7695	5050	11022	8257	15263	12775	19256	16934							8349	5944
	7	6612	3514	9891	6652	14245	11332	18306	15585							9744	6928
	8			8750	5057	13219	9897	17348	14245	21286	18332	25109				11132	7920
	9					12193	8453	16389	12897	20374	17048	24229	21023			12527	8912
	10					11167	7018	15431	11557	19461	15771	23349	19792	27156	23699	13914	9904
	11							14473	10209	18548	14487	22469	18554	26300	22496	15310	10896
	12							13523	8869	17643	13211	21597	17324	25452	21300	16697	11880
SR300	5	9709	6452													9391	6461
	6	8275	4372	12230	8131											11267	7753
	7	6833	2283	10715	5939	16958	12409									13143	9045
	8			9210	3745	15524	10320	18156	13914	22277	17073					15020	10338
	9					14090	8831	16988	12212	20844	14984	27597	21737			16896	11630
	10					12657	6151	15819	10517	19410	12904	26163	19658	31270	25090	18781	12922
	11							14643	8815	17967	10816	24720	17569	29899	23106	20658	14214
	12							13474	7113	16533	8727	23286	15480	28537	21121	22574	24924
SR350	5	13745	8532													15064	10382
	6	11435	5787	17313	10752	24285	17011									18082	12462
	7	9125	1841	14888	7240	21985	13666									21091	14533
	8			12462	3726	19684	10311	26156	19375	32093	23773					24109	16613
	9					17374	6966	24280	16641	29792	20419	39899	30526			27119	18693
	10							22398	13914	27842	17073	37589	27181	45321	35432	30137	20764
	11							20515	11188	25172	13728	35279	23835	43125	32253	33146	22844
	12							18639	8454	22870	10373	32978	20481	40939	29067	36164	24924
SR400	7	17949	7691													25496	16259
	8	15365	3638	23697	11384											29137	18587
	9			20994	7137	34403	21206									32774	20905
	10			18279	2891	31818	17162	37675	25730	46227	31571					36421	23224
	11					29234	13117	35569	22434	43643	27526	58052	41935			40058	25552
	12					26658	9072	33470	19137	41067	23481	55477	37890	66383	49676	43705	27871
	13							31364	15833	38483	19427	52892	33836	63927	45825	47343	30199
	14							29264	12537	35907	15383	50317	29792	61481	41982	50489	32518
15							27158	9240	33323	11338	47732	25797	59025	38140	54627	34845	
	16											45148	21702	56571	34297	58273	37164

Performance Cont.

Double Acting Actuator Output Torque (in-lbs)

MODEL	Air Pressure (Psig)									
	40	50	60	70	80	90	100	110	120	
DA040	55	71	85	100	115	129	142	157	171	
DA052	97	122	146	171	195	219	244	268	292	
DA063	178	223	267	313	356	401	446	490	535	
DA075	245	306	368	430	490	551	613	674	735	
DA083	383	476	574	671	766	861	957	1053	1149	
DA092	551	689	827	967	1103	1240	1378	1516	1654	
DA105	808	1009	1211	1416	1615	1817	2019	2221	2423	
DA125	1225	1532	1833	2149	2450	2757	3063	3369	3676	
DA140	2088	2611	3133	3662	4177	4699	5221	5743	6265	
DA160	3249	4061	4873	5697	6497	7309	8122	8934	9746	
DA190	5198	6497	7797	9115	10396	11695	12995	14294	15594	
DA210	6497	8122	9746	11394	12995	14619	16243	17868	19492	
DA240	9398	11753	14097	16480	18796	21151	23495	25850	28194	
DA270	14282	17856	21430	25046	28565	32139	35712	39286	42859	
DA300	16887	21270	27012	30393	33766	40519	44900	49390	54020	
DA350	25278	31840	40448	45502	50555	60663	67240	73960	80880	
DA400	36014	45375	57627	64832	72036	86445	95800	105380	1E+05	

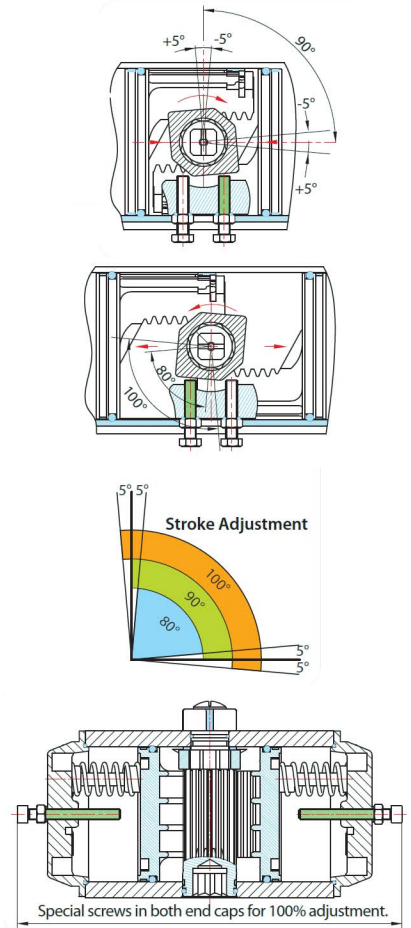

Weights (lbs)

Weights (Lbs)																	
MODEL	40	52	63	75	83	92	105	125	140	160	190	210	240	270	300	350	400
DA	2	3	4	6	7	10	13	19	29	44	72	87	122	184	283	462	616
SR		3	4	6	8	12	15	23	35	53	87	108	152	235	343	571	792

Maximum Air Consumption (Cu. inches) Per Stroke (Piston Displacement)

Model Action	52	63	75	83	92	105	125	140	160	190	210	240	270	300	350	400
CCW	7.3	12.9	18.3	26.2	39.1	58	97.6	152.5	225.7	359.9	457.5	671.2	1037.5	1811.7	2824	3416
CW	9.7	14.1	20.7	28.7	44.6	53.7	85.4	134.2	195.2	329.4	457.5	549.3	854.4	1451.8	2141	3208

Actuator Cycle Speed (sec.) 80psi 12 Spring

Action	Model	52	63	75	83	92	105	125	140	160	190	210	240	270	300	350	400
CCW	DA	0.50	0.70	0.70	0.80	1.00	1.50	2.00	2.50	3.00	4.00	4.50	6.00	8.00	12.00	14.00	15.00
	SR	0.20	0.20	0.20	0.30	0.45	0.65	1.00	1.50	2.45	3.00	3.50	5.10	7.50	10.00	13.00	16.00
CW	DA	0.50	0.70	0.70	0.80	1.00	1.50	2.00	2.50	3.00	4.00	4.50	6.00	8.00	12.00	14.00	15.00
	SR	0.20	0.20	0.20	0.25	0.30	0.40	0.50	1.00	1.25	1.75	2.25	3.25	5.50	7.50	10.00	11.00

- Bi-Directional Travel Stops
- Valves are manufactured with acceptable travel tolerance.
- KAMMAC standard two way rotation travel stops, provide a minimum rotation of -5 degrees to +5 degrees.
- Optional limiting 100% travel stops.
- Assures positive sealing, correct port alignment and longer valve life.
- Quarter turn valves such as butterflies, metal seated, multi-port and other specific rotation valves require actuators that are capable of compensating for the accumulation of tolerances that lead to valve malfunction and damage.