

**CRANE**<sup>®</sup>

brands you trust.



**FLOSCURCE**  
VALVES | ACTUATION | INSTRUMENTATION | STEAM SPECIALTIES

CRANE<sup>®</sup> Iron Valves

**CRANE**

©Copyright 2013 CRANE ChemPharma & Energy

[www.cranechempharma.com](http://www.cranechempharma.com)  
[www.craneenergy.com](http://www.craneenergy.com)

## Key Features & Applications



### Key Features & Benefits

- 1 Fully rated to ASME and MSS-SP Standards
- 2 Full Pressure Class Offering: Class 125, Class 150, Class 250, and Class 300
- 3 Complete size range availability from 2" through 24"

### Typical Applications

- Commercial Plumbing and HVAC
- Institutional HVAC
- Industrial Plumbing and HVAC
- Utility Applications

# Iron Valve Selection Guide and Figure Number Index

Cross Reference & Materials .....	4
Overview .....	5-6
Pressure/Temperature Ratings .....	5
C <sub>v</sub> Coefficients .....	5
Gate Section .....	7
Globe Section .....	18
Check Section .....	21
Technical Data .....	23
Installation Recommendations .....	26

CRANE® Figure No.	Catalog Page No.	Pressure Class	Stem: RS or NRS	Body/Trim IBBM, Ductile	Bonnet/Cap: BB, TB, Clamp	End Connections	Disc
<b>Iron Body Gate Valves</b>							
460	7	125	NRS	IBBM	BB	THD	SW
461	8	125	NRS	IBBM	BB	FLG	SW
473	9	125	NRS	AI	BB	FLG	
464 ½	10	125	RS, OS&Y	IBBM	BB	THD	
465 ½	11	125	RS, OS&Y	IBBM	BB	FLG	
475 ½	12	125	RS, OS&Y	AI	BB	FLG	
488	13	125/150	RS	Ductile Iron	Clamp	THD	
488 ½	14	125/150	RS	Ductile Iron	Clamp	FLG	
490	15	125/150	RS	IBBM Ductile Iron	Clamp	THD	
3E	16	250	NRS	IBBM	BB	FLG	
7 ½ E	17	250	RS, OS&Y	IBBM	BB	FLG	
<b>Iron Body Globe Valves</b>							
351	18	125	RS, OS&Y	IBBM	BB	FLG	BRZ
21E	20	250	RS, OS&Y	IBBM	BB	FLG	BRZ
<b>Iron Body Angle Valves</b>							
353	19	125	RS, OS&Y	IBBM	BB	FLG	BRZ
<b>Iron Body Stop Check Valves</b>							
28E	21	250 (straight flow)	RS, OS&Y	IBBM	BB	FLG	BRZ
30E	22	250 (90° angle flow)	RS, OS&Y	IBBM	BB	FLG	BRZ
<b>Iron Body Swing Check Valves</b>							
372	27	125		IBBM	BC	THD	BRZ
373	28	125		IBBM	BC	FLG	BRZ
373 ½	30	125		AI	BC	FLG	Iron
383	29	125 w/outside lever & weight		IBBM	BC	FLG	BRZ
39E	31	250		IBBM	BC	FLG	BRZ
346 ½	32	300 Y-Pattern		Ductile Iron	SC	THD	Iron

**NOTE:** The following valves have been discontinued: 465, 467, 484½, 485½, 486½, 487½, 490½, 1670, 1671, 14477, 7E, 254XR, 373RS, 375, 14493. Please consult factory\* for possible substitutions.

\* See back cover for Customer Service information.

## Cross Reference for Commonly Used Valves & Materials

### IRON VALVES

GATE	CRANE®	NIBCO	Milwaukee	Powell	Walworth	Stockham®
Class 125 NRS	461	F-619	F2882 A	1787	W719F	G-612
Class 125 OS&Y	465 ½	F-617-0	F2885 A	1793	W726F	G-623
Class 250 OS&Y	7 ½E	F-667-0	F2894 A	1797	W786F	F-667
<b>GLOBE</b>						
Class 125	351	F-718-B	F2981 A	241	W906F	G-512
<b>SWING CHECK</b>						
Class 125	373	F-918-B	F2974 A	559	W928F	G-931
<b>STOP CHECK</b>						
Class 250 Straight-Way Y-Pattern	28E	----	----	----	----	F-540
Class 250 Angle Y-Pattern	30E	F-869-B	----	----	----	F-541

### BRONZE VALVES

GATE	CRANE®	NIBCO	Milwaukee	Stockham®
Class 125 RS-Threaded	428	T-111	148	B-100
Class 125 NRS-Threaded	438	T-113	105	B-103
Class 125 RS-Solder	1330	S-111	149	B-108
Class 125 NRS-Solder	1320	S-113	115	B-104
Class 150 Union Bonnet	431UB	T-134	1151	B-120
Class 300 SS Trim	634E	T-174-SS	1184	B-145
<b>GLOBE</b>				
Class 125	1	T-211-B	502	B-16
Class 300 SS Trim	382P	T-275	593A	B-74
<b>CHECK</b>				
Class 125 Threaded	37	T-413-BY	509	B-319Y
Class 125 Solder	1340	S-413-B	1509	B-309Y
Class 300 Swing Check	76E	T-473-B	507	B-375
Class 300 Lift Check	366E	----	----	B-367

## Materials

### CAST IRON - ASTM A126, CLASS B

Used primarily for valve pressure retaining parts.  
Recommended to 450 °F (232 °C).

Chemical Requirements	Minimum	Maximum
Sulphur %	-	0.15
Phosphorus %	-	0.75
Tensile Requirements	Minimum	Maximum
Tensile Strength, psi	31,000	-
Transverse Test Load, lbs.	3,300	-
Deflection @ Center, in.	0.12	

### BRONZE

ASTM B584 C84400
ASTM B584 C86400
ASTM B61 C92200
ASTM B16 C36000
ASTM B62 C83600

### DUCTILE IRON - ASTM A536, 65-45-12

Chemical Requirements	Minimum %	Maximum %
Carbon (C)	3.5	3.9
Manganese (Mn)	0.15	0.35
Silicone (Si)	2.25	2.75
Sulphur (S)	0.01	0.025
Phosphorus (P)		0.05
Tensile Requirements	Minimum	Maximum
Tensile Strength, psi	65,000 Minimum	
Yield Strength, psi	45,000 Minimum	
Elongation (in 2")	12%	

## Overview

CRANE® iron body valves are proven performers in mechanical systems of commercial buildings throughout America. Chemical plants, steel mills, shipyards, refineries, pulp and paper mills, and utilities have also found that CRANE® iron body valves do the job better and longer for their many general services.

### QUALITY MANAGEMENT

CRANE® is committed to a philosophy of total quality management. It begins with design, to comply with pertinent MSS and ASME Standards. Continuous improvements are applied in a process to improve materials and services to meet or exceed customer needs.

### MATERIALS

The iron used as the basic valve material conforms to the chemical and physical requirements of the American Society of Testing and Materials A-126 Class B for Cast Iron Valves.

### RATED WORKING PRESSURES

The pressure-temperature ratings of CRANE® iron body valves in this catalog section are as follows:

Temp. °F	PRESSURE (PSIG)			
	Class 125 Cast Iron		Class 250 Cast Iron	
	Sizes	Sizes	Sizes	Sizes
	2-12	14-24	2-12	14-2
-20 to 100	200	150	500	300
150	200	150	500	300
200	190	135	460	280
225	180	130	440	270
250	175	125	415	260
275	170	120	395	250
300	165	110	375	240
325	155	105	355	230
350	150	100	335	220
375	145		315	210
400	140		290	200
425	130		270	
450	125		250	
500				
600				
650				

The temperature shown for a corresponding pressure rating is the temperature of the pressure containing shell of the component. In general, this temperature is the same as that of the contained fluid. Composition disc valves are excluded from these ratings.

### DESIGN

#### GATE VALVES-CLASSES 125 and 250

**Stem**—All stems are designed for ample strength and are machined to function easily. Backseats are provided on OS&Y valves.

**Packing Gland Assembly**—Glands and gland flanges have a ball and socket joint which assures alignment. It provides for proper packing compression without binding against the stem.

**Gasket**—Aramid fibers with SBR binder.

**Packing**—Braided flexible graphite with corrosion inhibitor or as specified with specific item.

**Disc**—Strong, solid wedge discs have disc guides for precision seating with minimum friction against body seats.

**Yoke and Bonnet**—One-piece yoke bonnets are utilized on 12" and smaller size OS&Y valves. Larger sizes have separate yokes and bonnets.

**Stuffing Box**—NRS valves have stuffing boxes assembled to bonnets to accommodate the packing gland assembly.

**Seat Ring**—Buttress-type seat rings are bottom-seated with accurately machined faces to match disc faces.

**Handwheel or Operating Nut**—Handwheels have large diameters for good leverage on operating nuts, a 2" square may be furnished on any NRS valve if specified.

#### Cv Coefficients\*

(For estimating purposes only)

Size	Gate	Globe	Swing Check
2	327	50	131
2½	480	74	192
3	742	114	297
4	1314	202	526
5	2129	327	852
6	3175	487	1270
8	5691	873	2276
10	8970	1376	3588
12	13351	—	5340
14	16277	—	6511
16	21562	—	8625
18	28715	—	11486
20	35760	—	14304
24	52165	—	20866
30	82563	—	—
36	119910	—	—

\*Fully open. Cv=GPM @ 1 PSI ΔP, 60°F Water

The above values for Swing Check Valves are correct only when the valve is fully open. This corresponds to a velocity of 6 ft./sec. for water flow.

## Overview

**Yoke Bushing**—Yoke bushings on OS&Y valves have Acme threads for stem engagement; and handwheels fit snugly over bushings. Handwheels are securely locked to yoke bushings with locknuts. A bolted yoke cap secures the yoke bushing to the yoke.

**Body**—Body sections are evenly distributed for maximum strength. Dimensions and drilling of end flanges of cast iron valves conform to the ASME Standard B16.1 for Classes 125 and 250 Cast Iron Flanges. Face-to-face dimensions comply with ASME Standard B16.10.

**DESIGN:**  
**GLOBE AND ANGLE VALVES-OUTSIDE SCREW AND YOKE-CLASSES 125 and 250**

CRANE® globe valves are highly efficient for services requiring frequent operations and throttling with pressure drop across the valve and about 20% of inlet pressure. Closer throttling, creating higher pressure drops, may cause cavitation or excessive velocities which could cause high noise levels, vibration and possible damage to the valve or adjacent piping.

**Stem**—Stems are machined with Acme threads which fully engage the yoke bushing threads at all times.

**Packing Gland Assembly**—Glands and gland flanges have a ball and socket joint which assures alignment and proper packing compression.

**Packing**—Braided flexible graphite with corrosion inhibitor or as specified with specific item.

**Backseat Bushing**—Bushings are threaded into bonnets, providing beveled seats for backseating on stem shoulders.

**Disc**—Bronze discs are furnished in Class 125 and 250 globe and angle valves, which are regrindable. Disc nuts thread into disc. The Class 250 nonreturn stop-check valve conforms to ASME boiler codes and utilizes a dashpot and piston design to cushion the disc action.

**Yoke Bonnet**—One-piece yoke bonnets are fastened to bodies with capscrews.

**Seat Rings**—Seat rings are bottom-seated and are readily renewable.

**Handwheel**—Handwheels have large diameters for ample leverage.

**Yoke Bushing**—Accurate Acme threads engage stem threads. Set screws fasten yoke bushings to yoke.

**Body**—Bodies are designed with uniform sections evenly distributed for maximum strength. Dimensions and drilling of end flanges on flanged valves conform to the ASME Standard B16.1 for Classes 125 and 250 Cast Iron Flanges. Face-to-face dimensions comply with the ASME Standard B16.10.

**DESIGN:**  
**SWING CHECK VALVES-CLASSES 125 and 250**

**Cap**—Caps are bolted to bodies.

**Hinge**—Hinges are precisely drilled for assembly with discs.

**Hinge Pin**—Pins are located by side plugs, screwed into bodies.

**Disc**—Disc faces are accurately machined for tight seal with seat rings.

**Seat Ring**—Buttress design of renewable seat rings provides bottom seating and good strength.

**Body**—Dimensions and drilling of end flanges on flanged valves conform to ASME Standard B16.1 for Classes 125 and 250 Cast Iron Flanges. Face-to-face dimensions comply with ASME B16.10.

**Figure 383 L&W:**

Swing Check valves sized 2"-12" come standard with an adjustable lever arm which can be orientated in any position in 15° increments. These valves can be installed in horizontal lines or in vertical lines with upward flow. 14"-24" valves must be specified at the time of inquiry and order with the installation orientation for horizontal or vertical-upward flow.

**ACCESSORIES**—CRANE® iron body valves may be furnished with motor operators, gearings, bypasses, floorstands, extension stems, lever and weight attachment or other accessories.

**MARKING**—Numerals indicate the size and pressure class. Cast arrows indicate direction of flow on check, globe, and angle valves.

**TESTING AND INSPECTION**—Before shipment, each valve is individually tested under pressure for soundness of castings and tight closure to MSS Standards.

**FINISH**—External cast iron parts are coated with a durable black finish.

**WEIGHTS AND DIMENSIONS**—Dimensions and weights shown in this catalog section are furnished for estimating purposes only and are subject to change without notice. It is our intent to maintain basic dimensional requirements of accepted standards.

## Class 125 • Bolted Bonnet • N-R Stem • Bronze Trim • Threaded

### 460 Gate Valve

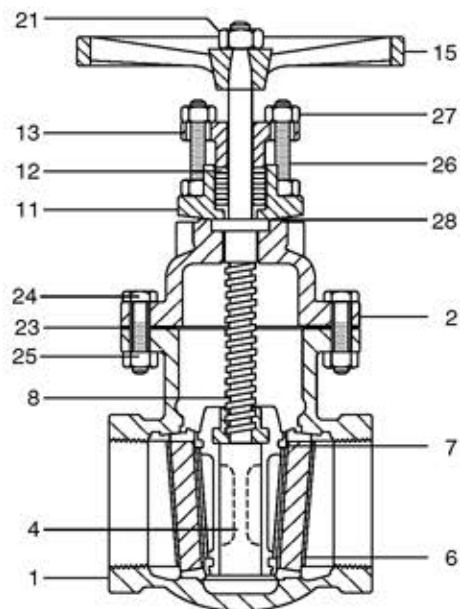

### Materials of Construction

No.	Description	Material	ASTM
1	Body	Cast Iron	A126 Class B
2	Bonnet	Cast Iron	A126 Class B
4	Disc	Bronze (2" - 3")	B584 C84400
		Cast Iron (4")	A126 Class B
6	Seat Ring	Bronze	B584 C84400
7	Disc Ring	Bronze (4")	B584 C84400
8	Stem	Manganese Bronze	B584 C86400
11	Stuffing Box	Ductile Iron	A536 Gr. 65-45-12
12	Packing	Braided Flexible Graphite with Corrosion Inhibitor	
13	Gland Flange	Ductile Iron	A536 Gr. 65-45-12
15	Handwheel	Ductile Iron	A536 Gr. 65-45-12
21	Handwheel Nut	Carbon Steel	A563 Gr. A
23	Bonnet Gasket	Aramid Fibers with SBR Binder	
24	Bonnet Bolt	Carbon Steel	A307 Gr. B
25	Bonnet Bolt Nut	Carbon Steel	A563 Gr. A
26	Gland Bolt	Carbon Steel	A307 Gr. B
27	Gland Bolt Nut	Carbon Steel	A563 Gr. A
28	Stuffing Box Gasket	Aramid Fibers with SBR Binder	
34	Stuffing Box Bolt*	Carbon Steel	A307 Gr. B
35	Stuffing Box Bolt Nut*	Carbon Steel	A563 Gr. A

\* Not shown

See page 5 for Pressure Temperature Ratings

### Industry Standards

MSS SP-70, Type 1

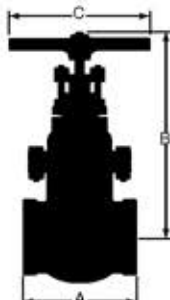

### Dimensions and Weights

Inches (millimeters) - Pounds (kilograms)

Valve Size	Dimensions			WT
	A	B	C	
2	5.38	11.31	8.00	25
	(137)	(287)	(203)	(11)
2 ½	6.62	12.40	8.00	31
	(168)	(315)	(203)	(14)
3	7.00	13.25	8.00	44
	(178)	(337)	(203)	(20)
4	8.00	16.31	10.00	71
	(203)	(414)	(254)	(32)

### 461 Gate Valve

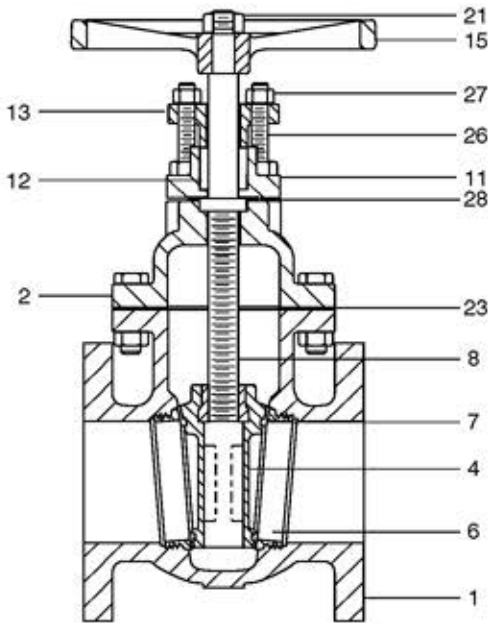

#### Dimensions and Weights Inches (millimeters) - Pounds (kilograms)

Valve Size	Dimensions			WT
	B	C	M	
2	11.31	8.00	7.00	30
	(287)	(203)	(178)	(14)
2 1/2	12.40	8.00	7.50	40
	(315)	(203)	(191)	(18)
3	13.25	8.00	8.00	56
	(337)	(203)	(203)	(25)
4	16.31	10.00	9.00	90
	(414)	(254)	(229)	(41)
5	18.00	10.00	10.00	126
	(457)	(254)	(254)	(57)
6	20.69	12.00	10.50	152
	(526)	(305)	(267)	(68)
8	24.12	14.00	11.50	260
	(613)	(356)	(292)	(117)
10	33.00	20.00	13.00	490
	(838)	(508)	(330)	(222)
12	36.50	20.00	14.00	672
	(927)	(508)	(356)	(304)
14	40.50	20.00	15.00	968
	(1029)	(508)	(381)	(440)
16	48.00	22.00	16.00	1180
	(1219)	(559)	(406)	(535)
18	50.75	22.00	17.00	1701
	(1289)	(559)	(432)	(772)
20	56.12	24.00	18.00	2188
	(1426)	(610)	(457)	(993)
24	64.00	30.00	20.00	3150
	(1626)	(762)	(508)	(1432)

### Materials of Construction

No.	Description	Material	ASTM
1	Body	Cast Iron	A125 Class D
2	Bonnet	Cast Iron	A126 Class B
4	Disc	Bronze (2" - 3")	B584 C84400
		Cast Iron (4" - 24")	A126 Class B
6	Seat Ring	Bronze (2" - 12")	B584 C84400
		Bronze (14" - 24")	B584 C84400
7	Disc Ring	Bronze (4" - 12")	B584 C84400
		Bronze (14" - 24")	B584 C84400
8	Stem	Manganese Bronze (2" - 12")	B584 C86400
		Copper-Silicon Bronze (14" - 24")	
11	Stuffing Box	Ductile Iron (2" - 8")	A536 Gr. 65-45-12
		Cast Iron (10" - 24")	A126 Class B
12	Packing	Braided Flexible Graphite with Corrosion Inhibitor	
13	Gland Flange	Ductile Iron (2" - 8")	A536 Gr. 65-45-12
		Ductile Iron (14" - 24")	A536 Gr. 65-45-12
14	Gland*	Bronze (10" - 12")	B584 C84400
15	Handwheel	Ductile Iron	A536 Gr. 65-45-12
21	Handwheel Nut	Carbon Steel	A563 Gr. A
23	Bonnet Gasket	Aramid Fibers with SBR Binder	
24	Bonnet Bolt*	Carbon Steel	A307 Gr. B
25	Bonnet Bolt Nut*	Carbon Steel	A563 Gr. A
26	Gland Bolt	Carbon Steel	A307 Gr. B
27	Gland Bolt Nut	Carbon Steel	A563 Gr. A
28	Stuffing Box Gasket	Aramid Fibers with SBR Binder	
34	Stuffing Box Bolt*	Carbon Steel	A307 Gr. B
35	Stuffing Box Bolt Nut*	Carbon Steel	A563 Gr. A
55	Gland Follower*	Ductile Iron (10" - 12")	A536 Gr. 65-45-12

\* Not shown  
See page 5 for Pressure Temperature Ratings

#### Industry Standards

MSS SP-70, Type 1





## Class 125 • Bolted Bonnet • N-R Stem • All Iron • Flanged

### 473 Gate Valve

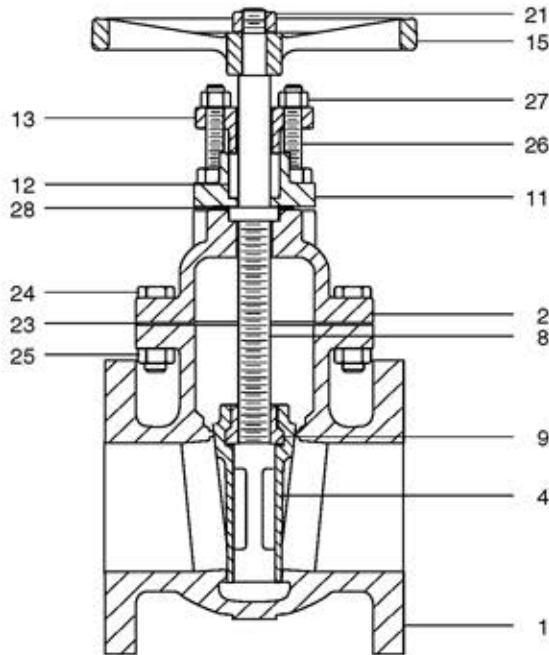

### Materials of Construction

No.	Description	Material	ASTM
1	Body	Cast Iron	A126 Class B
2	Bonnet	Cast Iron	A126 Class B
4	Disc	Cast Iron	A126 Class B
8	Stem	Stainless Steel	A276 Type 304
9	Disc Nut	13 CR SS (4" - 8")	A582 Type 416
11	Stuffing Box	Ductile Iron	A536 Gr. 65-45-12
12	Packing	Braided Flexible Graphite with Corrosion Inhibitor	
13	Gland Flange	Ductile Iron	A536 Gr. 65-45-12
15	Handwheel	Ductile Iron	A536 Gr. 65-45-12
21	Handwheel Nut	Carbon Steel	A563 Gr. A
23	Bonnet Gasket	Aramid Fibers with SBR Binder	
24	Bonnet Bolt	Carbon Steel	A307 Gr. B
25	Bonnet Bolt Nut	Carbon Steel	A563 Gr. A
26	Gland Bolt	Carbon Steel	A307 Gr. B
27	Gland Bolt Nut	Carbon Steel Zinc-Plated	A563 Gr. A
28	Stuffing Box Gasket	Aramid Fibers with SBR Binder	
34	Stuffing Box Bolt*	Carbon Steel	A307 Gr. B
35	Stuffing Box Bolt Nut*	Carbon Steel	A563 Gr. A

\* Not shown

See page 5 for Pressure Temperature Ratings

### Industry Standards

MSS SP-70, Type 1

### Dimensions and Weights

Inches (millimeters) - Pounds (kilograms)

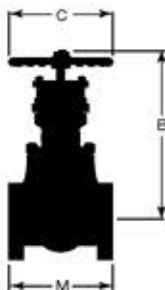

Valve Size	Dimensions			WT
	B	C	M	
2	11.31	8.00	7.00	30
	(287)	(203)	(178)	(14)
2 ½	12.40	8.00	7.50	44
	(315)	(203)	(191)	(20)
3	13.25	8.00	8.00	56
	(337)	(203)	(203)	(25)
4	16.31	10.00	9.00	91
	(414)	(254)	(229)	(41)
5	18.00	10.00	10.00	126
	(457)	(254)	(254)	(57)
6	20.69	12.00	10.50	152
	(526)	(305)	(267)	(69)
8	24.12	14.00	11.50	260
	(613)	(356)	(292)	(118)

## Class 125 • Bolted Bonnet • OS&Y • Bronze Trim • Threaded

### 464 1/2 Gate Valve

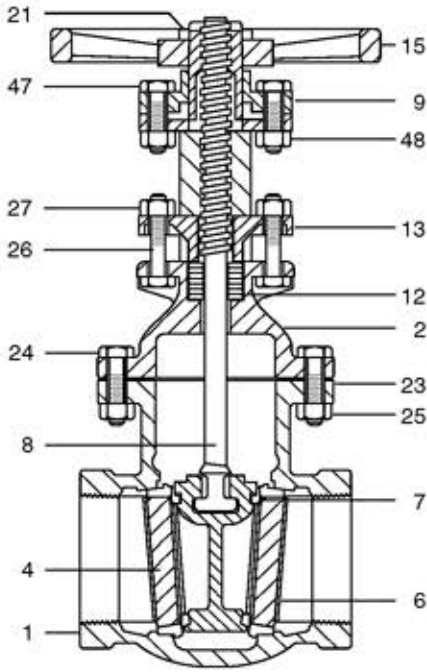

### Materials of Construction

No.	Description	Material	ASTM
1	Body	Cast Iron	A126 Class B
2	Yoke Bonnet	Cast Iron	A126 Class B
4	Disc	Bronze (2")	B61 C92200
		Bronze (2 1/2" - 3")	B584 C84400
		Cast Iron (4")	A126 Class B
6	Seat Ring	Bronze	B584 C84400
7	Disc Ring	Bronze (4")	B584 C84400
8	Stem	Manganese Bronze	B584 C86400
9	Yoke Sleeve	Manganese Bronze	B584 C86400
12	Packing	Braided Flexible Graphite with Corrosion Inhibitor	
13	Gland	Ductile Iron	A536 Gr. 65-45-12
15	Handwheel	Ductile Iron	A536 Gr. 65-45-12
21	Handwheel Nut	Sintered Nickel Steel	B484 Gr. 2 CL B Type II
23	Bonnet Gasket	Aramid Fibers with SBR Binder	
24	Bonnet Bolt	Carbon Steel	A307 Gr. B
25	Bonnet Bolt Nut	Carbon Steel	A563 Gr. A
26	Gland Bolt	Carbon Steel	A307 Gr. B
27	Gland Bolt Nut	Carbon Steel Zinc-Plated	A563 Gr. A
46	Yoke Cap*	Ductile Iron	A536 Gr. 65-45-12
47	Yoke Cap Bolt	Carbon Steel	A307 Gr. B
48	Yoke Cap Bolt Nut	Carbon Steel	A563 Gr. A

\* Not shown

See page 5 for Pressure Temperature Ratings

### Industry Standards

MSS SP-70, Type 1

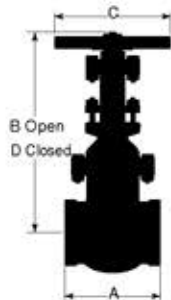

### Dimensions and Weights

Inches (millimeters) - Pounds (kilograms)

Valve Size	Dimensions				WT
	A	B	C	D	
2	5.38	14.75	8.00	12.50	25
	(137)	(375)	(203)	(318)	(11)
2 1/2	6.62	16.06	8.00	13.31	38
	(168)	(408)	(203)	(338)	(17)
3	7.00	17.38	8.00	13.88	46
	(178)	(441)	(203)	(353)	(21)
4	8.00	21.44	10.00	17.06	77
	(203)	(545)	(254)	(433)	(35)

## Class 125 • Bolted Bonnet • OS&Y • Bronze Trim • Flanged

### 465 1/2 Gate Valve

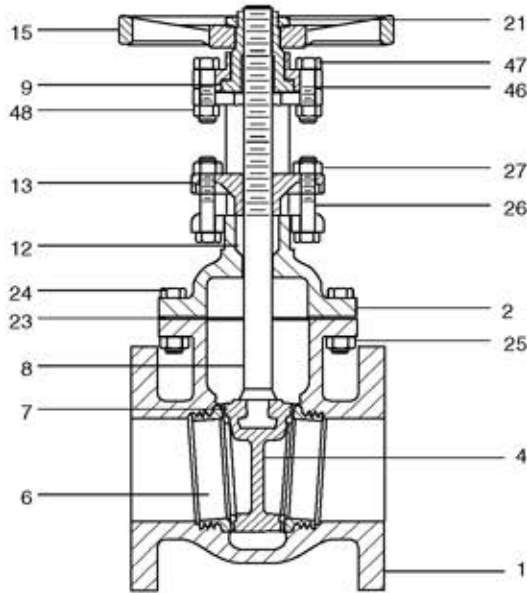

**Dimensions and Weights**  
Inches (millimeters) - Pounds (kilograms)

Valve Size	Dimensions			WT
	B	C	M	
2	14.75	8.00	7.00	33
	(375)	(203)	(178)	(15)
2 1/2	16.06	8.00	7.50	47
	(408)	(203)	(191)	(21)
3	17.38	8.00	8.00	58
	(441)	(203)	(203)	(26)
4	21.44	10.00	9.00	97
	(545)	(254)	(229)	(44)
5	25.81	10.00	10.00	135
	(656)	(254)	(254)	(61)
6	30.31	12.00	10.50	162
	(770)	(305)	(267)	(73)
8	37.75	14.00	11.50	280
	(959)	(356)	(292)	(126)
10	49.41	18.00	13.00	502
	(1255)	(457)	(330)	(228)
12	56.81	18.00	14.00	670
	(1442)	(457)	(356)	(304)
14	64.88	20.00	15.00	1093
	(1648)	(508)	(381)	(496)
16	75.25	22.00	16.00	1425
	(1911)	(559)	(406)	(647)
18	82.00	22.00	17.00	1738
	(2083)	(559)	(432)	(789)
20	90.62	24.00	18.00	2085
	(2302)	(610)	(457)	(946)
24	105.38	30.00	20.00	3183
	(2677)	(762)	(508)	(1445)

### Materials of Construction

No.	Description	Material	ASTM
1	Body	Cast Iron	A126 Class B
2	Bonnet	Cast Iron	A126 Class B
4	Disc	Bronze (2")	B61 C92200
		Bronze (2 1/2" & 3")	B584 C84400
		Cast Iron (4" - 24")	A126 Class B
6	Body Seat Ring	Bronze	B584 C84400
7	Disc Seat Ring	Bronze	B584 C84400
8	Stem	Manganese Bronze (2" - 12")	B584 C86400
		Brass (14" - 36")	
9	Yoke Sleeve	Manganese Bronze (2" - 12")	B584 C86400
		Ductile Iron (14" - 24")	A536 Gr. 65-45-12
10	Gland*	Bronze (10" & 12")	B584 C84400
	Gland Flange*	Ductile Iron (10" & 12")	A536 Gr. 65-45-12
12	Packing	Braided Flexible Graphite with Corrosion Inhibitor	
15	Handwheel	Ductile Iron	A536 Gr. 65-45-12
21	Handwheel Nut	Sintered Nickel Steel (2" - 8")	B484 Gr. 2 CL B Type II
		Ductile Iron (10" - 24")	A536 Gr. 65-45-12
23	Bonnet Gasket	Aramid Fibers with SBR Binder	
24	Bonnet Bolt	Carbon Steel	A307 Gr. B
25	Bonnet Bolt Nut	Carbon Steel	A563 Gr. A
26	Gland Bolt	Carbon Steel (2" - 12")	A307 Gr. B
26	Gland Eyebolt*	Carbon Steel (14" - 24")	
27	Gland Bolt Nut	Carbon Steel	A563 Gr. A
46	Yoke Cap	Ductile Iron (2" - 8")	A536 Gr. 65-45-12
		Cast Iron (10" - 12")	A126 Class B
47	Yoke Cap Bolt	Carbon Steel (2" - 12")	A307 Gr. B
48	Yoke Cap Bolt Nut	Carbon Steel (2" - 12")	A563 Gr. A
49	Stem Collar Seat*	Brass (14" - 24")	
50	Disc Pin*	Brass (14" - 24")	
51	Yoke Bolt*	Carbon Steel (14" - 24")	
52	Yoke Bolt Nut*	Carbon Steel (14" - 24")	
53	Yoke to Bonnet Bolt*	Carbon Steel (14" - 24")	
54	Backseat Bushing*	Brass (14" - 24")	
55	Eyebolt Pin*	Carbon Steel (14" - 24")	
56	Yoke*	Cast Iron (14" - 24")	

\* Not shown

See page 5 for Pressure Temperature Ratings

### Industry Standards

MSS SP-70, Type 1

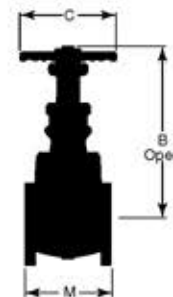

## Class 125 • Bolted Bonnet • OS&Y • All Iron • Flanged

### 475 1/2 Gate Valve

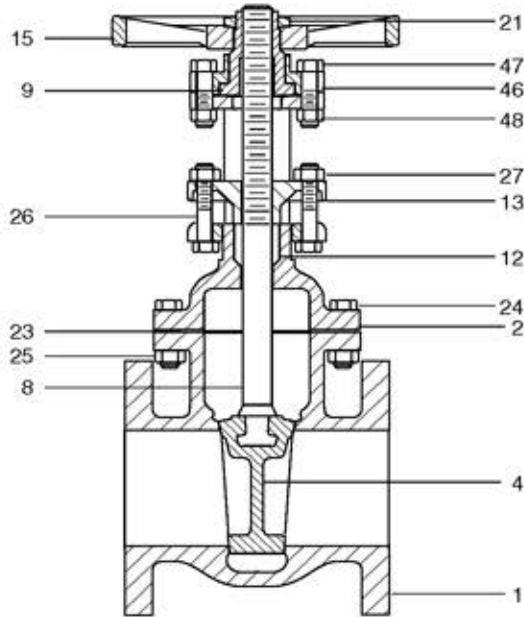

#### Dimensions and Weights Inches (millimeters) - Pounds (kilograms)

Valve Size	Dimensions			WT
	B	C	M	
2	14.75	8.00	7.00	33
	(375)	(203)	(178)	(15)
2 1/2	16.06	8.00	7.50	47
	(408)	(203)	(191)	(21)
3	17.38	8.00	8.00	58
	(441)	(203)	(203)	(26)
4	21.44	10.00	9.00	97
	(545)	(254)	(229)	(44)
5	25.81	10.00	10.00	135
	(656)	(254)	(254)	(61)
6	30.31	12.00	10.50	162
	(770)	(305)	(267)	(73)
8	37.75	14.00	11.50	280
	(959)	(356)	(292)	(126)
10	49.41	18.00	13.00	502
	(1255)	(475)	(330)	(228)
12	56.81	18.00	14.00	670
	(1442)	(457)	(356)	(304)
14	64.38	20.00	15.00	1093
	(1635)	(508)	(381)	(497)
16	75.25	22.00	16.00	1425
	(1911)	(559)	(406)	(647)
18	82.00	22.00	17.00	1738
	(2083)	(559)	(432)	(790)
20	90.62	24.00	18.00	2085
	(2302)	(610)	(457)	(911)
24	105.28	30.00	20.00	3183
	(2674)	(762)	(508)	(1446)

### Materials of Construction

No.	Description	Material	ASTM
1	Body	Cast Iron	A126 Class B
2	Bonnet	Cast Iron	A126 Class B
4	Disc	Cast Iron	A126 Class B
6	Seat Ring*	Cast Iron (12" - 24")	A126 Class B
8	Stem	Carbon Steel, Nickel-Plated	A108
9	Yoke Sleeve	Manganese Bronze	B584 C86400
12	Packing	Braided Flexible Graphite with Corrosion Inhibitor	
13	Gland	Ductile Iron (2" - 8")	A536 Gr. 65-45-12
		Carbon Steel Zinc-Plated (10" - 24")	A108
15	Handwheel	Ductile Iron	A536 Gr. 65-45-12
21	Handwheel Nut	Sintered Nickel Steel (2" - 10")	B484 Gr. 2 CL B Type II
		Ductile Iron (12" - 24")	A536 Gr. 65-45-12
23	Bonnet Gasket	Aramid Fibers with SBR Binder	
24	Bonnet Bolt	Carbon Steel	A307 Gr. B
25	Bonnet Bolt Nut	Carbon Steel	A563 Gr. A
26	Gland Bolt	Carbon Steel	A307 Gr. B
27	Gland Bolt Nut	Carbon Steel Zinc-Plated	A563 Gr. A
46	Yoke Cap	Ductile Iron	A536 Gr. 65-45-12
47	Yoke Cap Bolt	Carbon Steel	A307 Gr. B
48	Yoke Cap Bolt Nut	Carbon Steel	A563 Gr. A
55	GLD Follower*	Ductile Iron (10" - 24")	A536 Gr. 65-45-12

\* Not shown  
See page 5 for Pressure Temperature Ratings

#### Industry Standards

MSS SP-70, Type 1

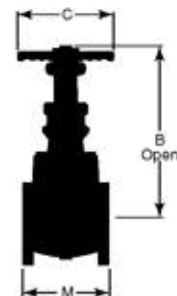

## Class 150 • U-Bolt Bonnet • Rising Stem • All Iron • Threaded

### 488 Gate Valve

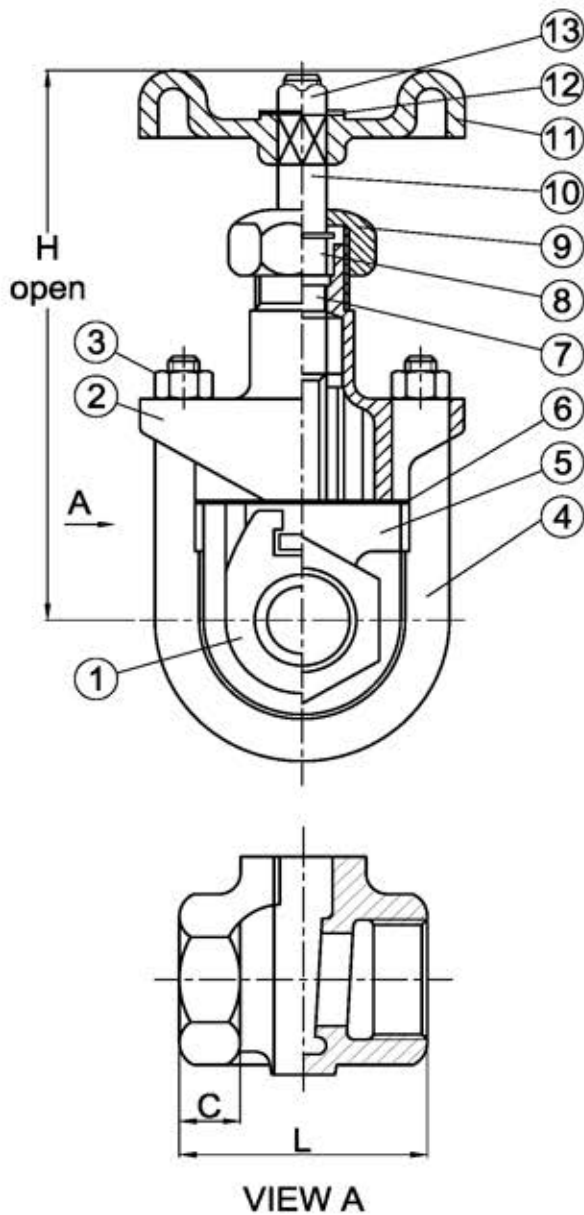

Size	Pressure Rating
¼ - 2"	225 PSI WOG (Non-Shock)
2½ - 4"	175 PSI WOG (Non-Shock)

### Materials of Construction

No.	Description	Material	ASTM
1	Disc	Ductile Iron	A536
2	Bonnet	Ductile Iron	A536
3	Nut	Steel ASTM	A563
4	"U"-Bolt	Steel ASTM	A307
5	Body	Ductile Iron	A536
6	Gasket	Aramid Fiber with Nitrile Binder	
7	Packing	Die-formed Compressed Graphite	
8	Gland	Stainless Steel	A276-410
9	Packing Nut	Ductile Iron	A536
10	Stem	Stainless Steel	A276-410
11	Handwheel	Cast Iron	A126 Gr. B
12	Name Plate	Aluminum	
13	Wheel Nut	Steel	A563 Gr. A

\* Not shown

See page 5 for Pressure Temperature Ratings

Industry Standards
MSS SP-70
ASME B16.42

### Dimensions and Weights Inches (millimeters) - Pounds (kilograms)

Valve Size	Dimensions			WT
	H	L	C	
¼	5.00	2.09	.47	1.50
	(125)	(53)	(11)	(.68)
⅜	5.00	2.09	.47	1.50
	(125)	(53)	(11)	(.68)
½	5.00	2.09	.47	1.50
	(125)	(53)	(11)	(.68)
¾	6.22	2.52	.50	2.0
	(160)	(63)	(12.7)	(.90)
1	7.50	2.63	.63	3.0
	(190)	(67)	(16)	(1.36)
1¼	9.00	2.91	.70	5.0
	(228)	(73)	(18)	(2.26)
1½	9.14	3.14	.75	6.5
	(232)	(79)	(19)	(2.94)
2	11.58	3.89	.75	10.0
	(293)	(99)	(19)	(4.53)
2½	12.88	4.59	.91	16.0
	(327)	(116)	(23)	(7.25)
3	14.77	4.92	.91	24.0
	(375)	(124)	(23)	(10.8)
4	19.30	5.93	.98	48.0
	(490)	(150)	(24)	(21.7)

## Class 125 • U-Bolt Bonnet • Rising Stem • All Iron • Flanged

### 488 1/2 Gate Valve

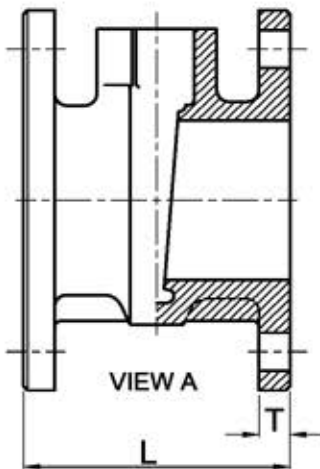
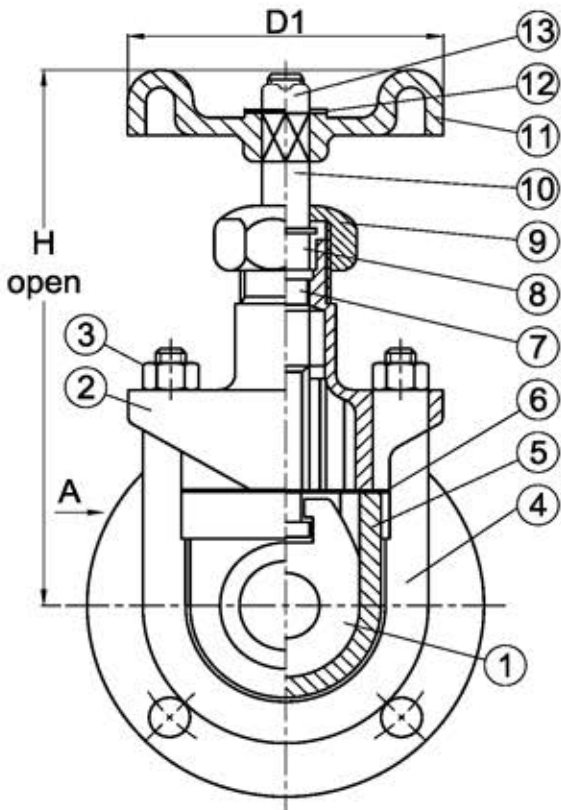

Size	Pressure Rating
1 - 2"	225 PSI WOG (Non-Shock)
2½ - 4"	175 PSI WOG (Non-Shock)

### Materials of Construction

No.	Description	Material	ASTM
1	Disc	Ductile Iron	A536
2	Bonnet	Ductile Iron	A536
3	Nut	Steel ASTM	A307 Gr. A
4	"U"-Bolt	Steel ASTM	A307 Gr. A
5	Body	Ductile Iron	A536
6	Gasket	Aramid Fiber with Nitrile Binder	
7	Packing	Die-formed Compressed Graphite	
8	Gland	Stainless Steel	A276-410
9	Packing Nut	Ductile Iron	A536
10	Stem	Stainless Steel	A276-410
11	Handwheel	Cast Iron	A126 Gr. B
12	Name Plate	Aluminum	
13	Wheel Nut	Steel	A307 Gr. A

See page 5 for Pressure Temperature Ratings

### Industry Standards

MSS SP-70, Type 1

ASME B16.42

### Dimensions and Weights

Inches (millimeters) - Pounds (kilograms)

Valve Size	Dimensions				WT
	H	L	D1	T	
1	7.50	3.19	2.95	.32	6.0
	(190)	(81)	(75)	(8)	(2.7)
1½	9.14	3.74	3.75	.32	11.0
	(232)	(95)	(95)	(8)	(5)
2	11.58	4.25	3.98	.32	16.0
	(293)	(108)	(101)	(8)	(7.3)
2½	12.88	4.94	4.75	.32	24.0
	(327)	(125)	(121)	(8)	(11)
3	14.77	5.06	6.00	.37	34.0
	(375)	(129)	(152)	(9)	(15.4)
4	19.30	6.75	9.00	.50	62.0
	(490)	(171)	(229)	(13)	(28.1)

## Class 150 • U-Bolt Bonnet • Rising Stem • Bronze Trim • Threaded

### 490 Gate Valve

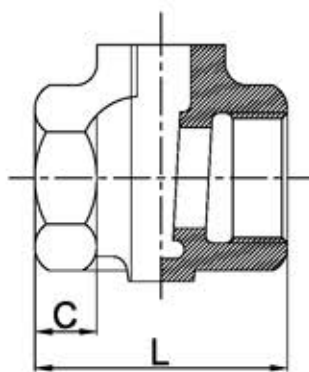
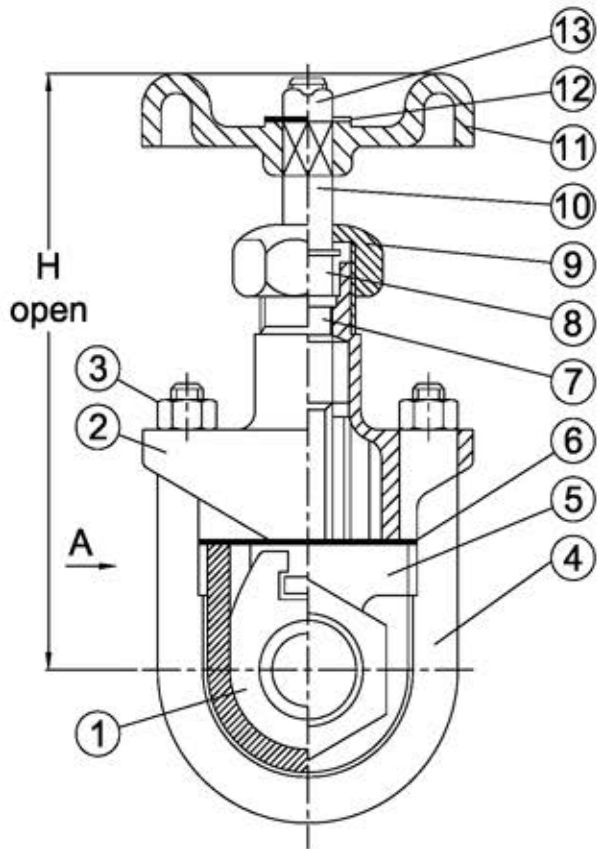

VIEW A

Size	Pressure Rating	
¼ - 2"	150 PSI WSP	225 PSI WOG (Non-Shock)
2½ - 4"	125 PSI WSP	175 PSI WOG (Non-Shock)

### Materials of Construction

No.	Description	Material	ASTM
1	Disc	Cast Bronze	B62
2	Bonnet	Ductile Iron	A536
3	Nut	Steel ASTM	A307 Gr. A
4	"U"-Bolt	Steel ASTM	A307 Gr. A
5	Body	Ductile Iron	A536
6	Gasket	Aramid Fiber with Nitrile Binder	
7	Packing	Die-formed Compressed Graphite	
8	Gland	Brass	B16
9	Packing Nut	Ductile Iron	A536
10	Stem	Brass	B16
11	Handwheel	Cast Iron	A126 Gr. B
12	Name Plate	Aluminum	
13	Wheel Nut	Steel	A307 Gr. A

See page 5 for Pressure Temperature Ratings

### Industry Standards

MSS SP-70, Type 1

ASME B16.42

### Dimensions and Weights

Inches (millimeters) - Pounds (kilograms)

Valve Size	Dimensions			WT
	H	L	C	
¼	5.00	2.09	.47	1.50
	(125)	(53)	(11)	(.68)
⅜	5.00	2.09	.47	1.50
	(125)	(53)	(11)	(.68)
½	5.00	2.09	.47	1.50
	(125)	(53)	(11)	(.68)
¾	6.22	2.52	.51	2.0
	(160)	(63)	(12.7)	(.90)
1	7.50	2.64	.63	3.0
	(190)	(67)	(16)	(1.36)
1¼	9.00	2.91	.70	5.0
	(228)	(73)	(18)	(2.26)
1½	9.14	3.15	.75	6.5
	(232)	(79)	(19)	(2.94)
2	11.58	3.90	.75	10.0
	(293)	(99)	(19)	(4.53)
2½	12.88	4.60	.90	16.0
	(327)	(116)	(23)	(7.25)
3	14.77	4.92	.90	24.0
	(375)	(124)	(23)	(10.8)
4	19.30	5.94	.98	48.0
	(490)	(150)	(24)	(21.7)

## Class 250 • Bolted Bonnet • N-R Stem • Bronze Trim • Flanged

### 3E Gate Valve

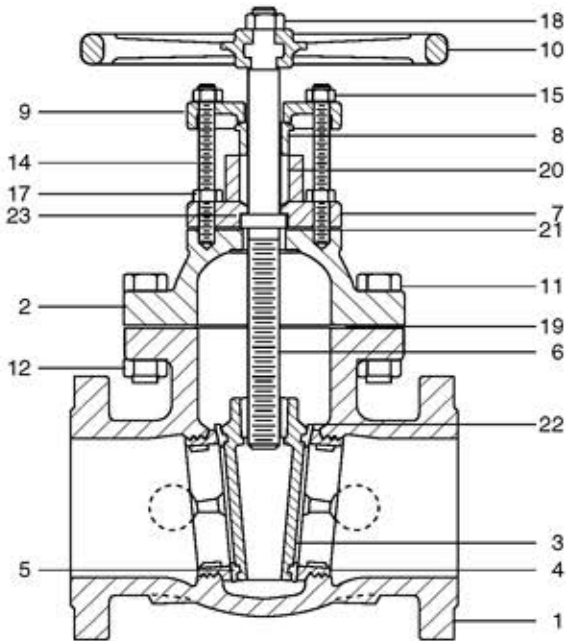

#### Industry Standards

MSS SP-70, Type 1

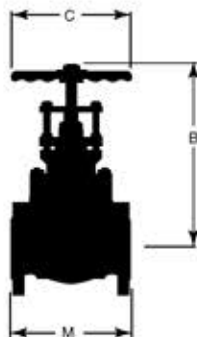

### Materials of Construction

No.	Description	Material	ASTM
1	Body	Cast Iron	A126 Class B
2	Bonnet	Cast Iron	A126 Class B
3	Disc	Bronze (2" - 4")	B584 C84400
		Cast Iron (6" - 12")	A126 Class B
4	Seat Ring	Bronze	B584 C84400
5	Disc Ring	Bronze (6" - 12")	B584 C84400
6	Stem	Manganese Bronze (2" - 8")	B584 C86400
		Naval Brass (10")	B21 C48500
		Manganese Bronze (12")	B138 67500
7	Stuffing Box	Ductile Iron (2" - 4")	A536 Gr. 65-45-12
		Cast Iron (6" - 12")	A126 Class B
8	Gland	Ductile Iron (2" - 4")	A536 Gr. 65-45-12
		Bronze (6" - 12")	B584 C84400
9	Gland Flange	Ductile Iron (6" - 12")	A536 Gr. 65-45-12
10	Handwheel	Ductile Iron	A536 Gr. 65-45-12
11	Bonnet Bolts	Carbon Steel	A307 Gr. B
12	Bonnet Bolt Nuts	Carbon Steel	A563 Gr. A
13	Stuffing Box Bolts*	Carbon Steel	A307 Gr. B
14	Gland Studs	Carbon Steel (2 1/2" - 6")	A108
		Carbon Steel (2", 8" - 12")	A307 Gr. B
15	Gland Stud or Bolt Nuts	Steel Zinc-Plated	A563 Gr. A
16	Stuffing Box Studs*	Carbon Steel	A108
17	Stuff Box Stud - Bolt Nuts	Carbon Steel	A563 Gr. A
18	Handwheel Nut	Carbon Steel	A563 Gr. A
19	Bonnet Gasket	Aramid Fibers with SBR Binder	
20	Packing	Braided Flexible Graphite with Corrosion Inhibitor	
21	Stuffing Box Gasket	Aramid Fibers with SBR Binder	
22	Disc Bushing	Bronze	B21 C48200
23	Identification Plate	Aluminum	

\* Not shown

See page 5 for Pressure Temperature Ratings

### Dimensions and Weights

Inches (millimeters) - Pounds (kilograms)

Valve Size	Dimensions			WT
	B	C	M	
2	11.94	8.00	8.50	47
	(303)	(203)	(216)	(21)
2 1/2	12.94	8.00	9.50	84
	(328)	(203)	(241)	(38)
3	14.50	10.00	11.12	113
	(368)	(254)	(282)	(51)
4	17.38	12.00	12.00	175
	(441)	(305)	(305)	(79)
6	23.00	16.00	15.88	335
	(584)	(406)	(403)	(151)
8	30.75	20.00	16.50	545
	(781)	(508)	(419)	(246)
10	36.00	22.00	18.00	854
	(914)	(559)	(457)	(385)
12	39.75	24.00	19.75	1250
	(1010)	(610)	(502)	(563)



## Class 250 • Bolted Bonnet • OS&Y • Bronze Trim • Flanged

### 7 1/2E Gate Valve

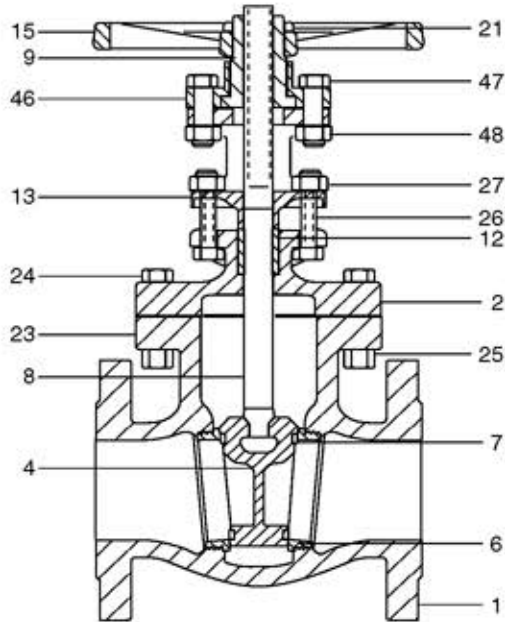

#### Industry Standards

MSS SP-70, Type 1

### Materials of Construction

No.	Description	Material	ASTM
1	Body	Cast Iron	A126 Class B
2	Bonnet	Cast Iron	A126 Class B
4	Disc	Bronze (2" - 3")	B584 C84400
		Cast Iron (4" - 12")	A126 Class B
6	Seat Ring	Bronze	B584 C84400
7	Disc Ring	Bronze (4" - 12")	B584 C84400
8	Stem	Manganese Bronze (2" - 4", 6" - 8")	B584 C86400
		Naval Brass (5", 10", 12")	B21 C48500
9	Yoke Sleeve	Manganese Bronze	B584 C86400
12	Packing	Braided Flexible Graphite with Corrosion Inhibitor	
13	Gland	Ductile Iron (2" - 4", 6")	A536 Gr. 65-45-12
		Bronze (8" - 12")	B584 C84400
14	Gland Flange*	Carbon Steel (5")	A307 Gr. B
		Ductile Iron (8" - 12")	A536 Gr. 65-45-12
15	Handwheel	Ductile Iron	A536 Gr. 65-45-12
21	Handwheel Nut	Sintered Nickel Steel (2" - 6")	B484 Gr. 2 Class B Type II
		Ductile Iron (8" - 12")	A536 Gr. 65-45-12
23	Bonnet Gasket	Aramid Fibers with SBR Binder	
24	Bonnet Bolt	Carbon Steel	A307 Gr. B
25	Bonnet Bolt Nut	Carbon Steel	A563 Gr. A
26	Gland Bolt	Carbon Steel (2" - 4", 6" - 8")	A307 Gr. B
		Carbon Steel (5", 10", 12")	A307 Gr. B
27	Gland Bolt Nut	Carbon Steel Zinc-Plated	A563 Gr. A
46	Yoke Cap	Ductile Iron (2" - 4", 6")	A536 Gr. 65-45-12
		Cast Iron (8")	A126 Class B
47	Yoke Cap Bolt	Carbon Steel	A307 Gr. B
48	Yoke Cap Bolt Nut	Carbon Steel	A563 Gr. A
51	Yoke Hub Bolt*	Carbon Steel (5", 10", 12")	
52	Yoke Hub Bolt Nut*	Carbon Steel (5", 10", 12")	
53	Yoke Pad Bolt*	Carbon Steel (5", 10", 12")	

\* Not shown

See page 5 for Pressure Temperature Ratings

### Dimensions and Weights

Inches (millimeters) - Pounds (kilograms)

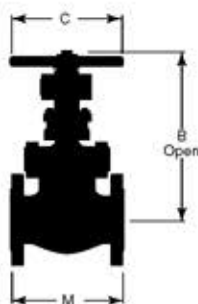

Valve Size	Dimensions			WT
	B	C	M	
2	15.06	8.00	8.50	54
	(382)	(203)	(216)	(24)
2 1/2	16.69	8.00	9.50	80
	(424)	(203)	(241)	(36)
3	18.75	10.00	11.12	114
	(476)	(254)	(282)	(52)
4	23.44	12.00	12.00	174
	(595)	(305)	(305)	(79)
5	24.00	14.00	15.00	280
	609	356	381	127
6	31.75	16.00	15.88	332
	(806)	(406)	(403)	(151)
8	39.88	18.00	16.50	600
	(1,012)	(457)	(419)	(270)
10	41.75	22.00	18.00	920
	(1060)	(559)	(457)	(417)
12	47.00	24.00	19.75	1400
	(1193)	(610)	(502)	(635)

### 351 Globe Valve

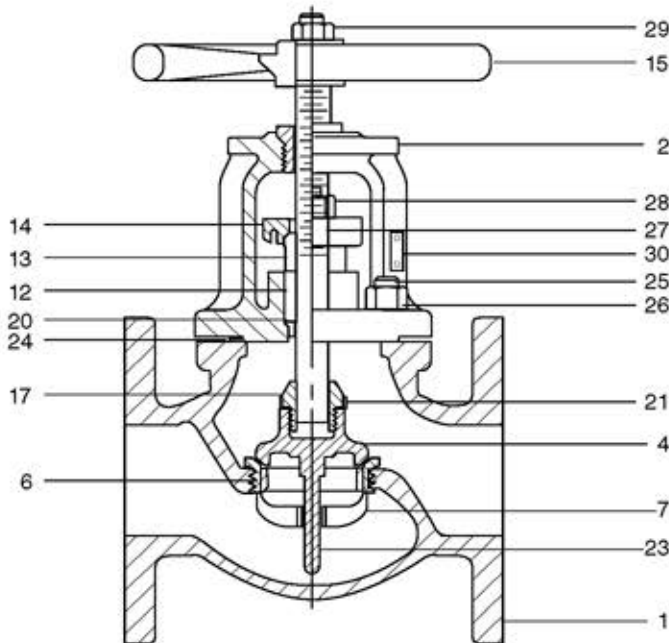

### Materials of Construction

No.	Description	Material	ASTM
1	Body	Cast Iron	A126 Class B
2	Bonnet	Cast Iron	A126 Class B
4	Disc	Bronze (2" - 6")	B584 C84400
		Cast Iron (8" - 10")	A126 Class B
6	Body Seat Ring	Bronze	B584 C84400
7	Disc Seat Ring	Bronze (8" & 10")	B584 C84400
8	Stem	Manganese Bronze	B584 C86400
9	Yoke Bushing	Manganese Bronze	B584 C86400
12	Packing	Braided Flexible Graphite with Corrosion Inhibitor	
13	Gland	Brass (2" - 4")	B16 C36000
		Bronze (5" - 10")	B584 C84400
14	Gland Flange	Ductile Iron	A536 Gr. 65-45-12
15	Handwheel	Ductile Iron	A536 Gr. 65-45-12
17	Disc Stem Ring	Bronze	B584 C84400
20	Stem Hole Bushing	Brass	B16 C36000
21	Locking Device	18-8 SST Sheet (2" - 6")	A167
22	Disc Guide Stem*	Brass (8" & 10")	B16 C36000
23	Disc Guide Stem Pin	Brass (8" & 10")	B16 C36000
24	Bonnet Gasket	Aramid Fibers with SBR Binder	
25	Bonnet Studs	Steel	A108
26	Bonnet Stud Nuts	Steel	A563 Gr. A
27	Gland Studs	Naval Brass	B21 C48200
28	Gland Stud Nuts	Brass	B16 C36000
29	Handwheel Nut	Steel - Phos. Coated	A563 Gr. A
30	Identification Plate	Aluminum	

\* Not shown

See page 5 for Pressure Temperature Ratings

#### Industry Standards

MSS SP-85, Type 1

### Dimensions and Weights

Inches (millimeters) - Pounds (kilograms)

Valve Size	Dimensions			WT
	B	C	M	
2	11.12	8.00	8.00	35
	(282)	(203)	(203)	(15)
2 ½	11.50	8.00	8.50	40
	(292)	(203)	(216)	(18)
3	13.25	9.00	9.50	57
	(337)	(229)	(241)	(26)
4	15.50	10.00	11.50	95
	(394)	(254)	(292)	(43)
5	17.50	10.00	13.00	126
	(445)	(254)	(330)	(57)
6	19.50	12.00	14.00	176
	(495)	(305)	(356)	(80)
8	25.00	16.00	19.50	344
	(635)	(406)	(495)	(156)
10	30.50	18.00	24.50	570
	(775)	(457)	(622)	(259)

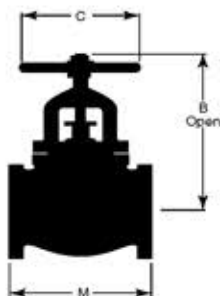

## Class 125 • Bolted Bonnet • OS&Y • Bronze Trim • Flanged

### 353 Globe Valve

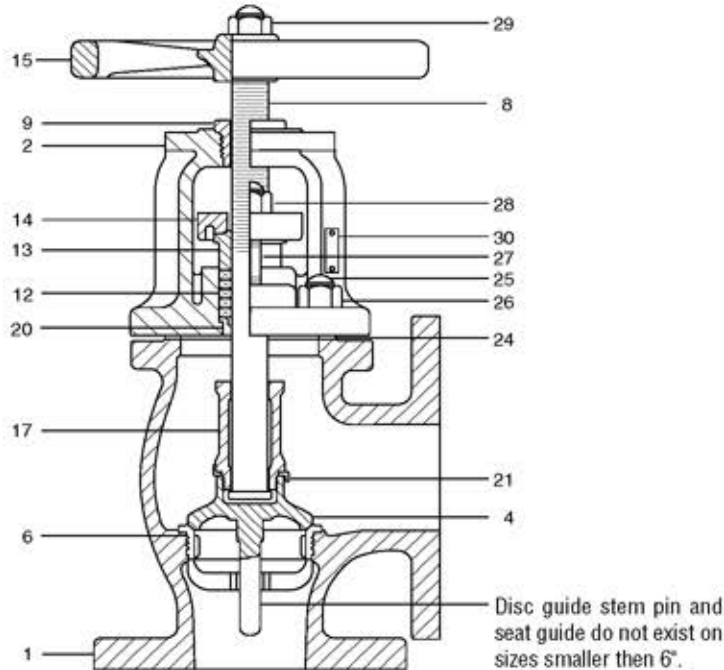

### Materials of Construction

No.	Description	Material	ASTM
1	Body	Cast Iron	A126 Class B
2	Bonnet	Cast Iron	A126 Class B
4	Disc	Bronze	B584 C84400
6	Seat Ring	Bronze	B584 C84400
8	Stem	Manganese Bronze	B584 C86400
9	Yoke Bushing	Manganese Bronze	B584 C86400
12	Packing	Braided Flexible Graphite with Corrosion Inhibitor	
13	Gland	Brass (2" - 4")	B16 C36000
		Bronze (6")	B584 C84400
14	Gland Flange	Ductile Iron	A536 Gr. 65-45-12
15	Handwheel	Ductile Iron	A536 Gr. 65-45-12
17	Disc Stem Ring	Bronze	B584 C84400
20	Stem Hole Bushing	Brass	B16 C36000
21	Locking Device	18-8 Stainless Steel	A167
24	Bonnet Gasket	Aramid Fibers with SBR Binder	
25	Bonnet Studs	Carbon Steel	A108
26	Bonnet Stud Nuts	Carbon Steel	A563 Gr. A
27	Gland Studs	Naval Brass	B21 C48200
28	Gland Stud Nuts	Brass	B16 C36000
29	Handwheel Nut	Carbon Steel	A563 Gr. A
30	Identification Plate	Aluminum	

\* Not shown  
See page 5 for Pressure Temperature Ratings

#### Industry Standards

MSS SP-85, Type 2

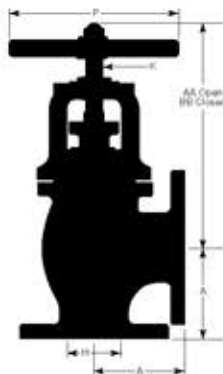

### Dimensions and Weights

Inches (millimeters) - Pounds (kilograms)

Valve Size	Dimensions						WT
	A	H	K	P	AA	BB	
2	4.00	2.00	0.88	8.00	11.00	10.25	32
	(102)	(51)	(22)	(203)	(279)	(260)	(15)
2 1/2	4.25	2.50	0.88	8.00	11.50	10.50	38
	(108)	(64)	(22)	(203)	(292)	(267)	(17)
3	4.75	3.00	1.00	9.00	12.75	11.75	54
	(121)	(76)	(25)	(229)	(324)	(299)	(25)
4	5.75	4.00	1.12	10.00	15.00	13.75	88
	(146)	(102)	(29)	(254)	(381)	(349)	(40)
6	7.00	6.00	1.25	12.00	19.50	17.75	158
	(178)	(152)	(32)	(305)	(495)	(451)	(72)

### 21E Globe Valve

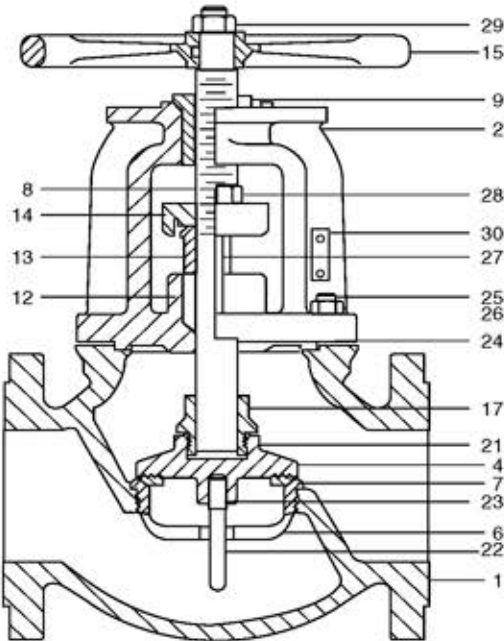

### Materials of Construction

No.	Description	Material	ASTM
1	Body	Cast Iron	A126 Class B
2	Bonnet	Cast Iron	A126 Class B
4	Disc	Bronze (2" - 3")	B61
		Cast Iron (4" - 8")	A126 Class B
6	Body Seat Ring	Bronze	B61
7	Disc Seat Ring	Bronze (6" - 8")	B61
8	Stem	Manganese Bronze	B584 C86400
9	Yoke Bushing	Manganese Bronze	B584 C86400
12	Packing	Braided Flexible Graphite with Corrosion Inhibitor	
13	Gland	Bronze	B62
14	Gland Flange	Steel (2", 3" & 6")	A181
		Ductile Iron	A536
15	Handwheel	Ductile Iron	A536
17	Disc Stem Ring	Bronze	B62
21	Locking Device	18-8 SST Sheet (2" - 5")	A167
22	Disc Guide Stem	Steel (6" - 8")	A108
23	Disc Guide Stem Pin	Steel (6" - 8")	B108
24	Gasket	Aramid Fibers with SBR Binder	
25	Bonnet Studs	Steel	A108
26	Bonnet Stud Nuts	Steel	A563 Gr. A
27	Gland Studs	Steel - Phos. Coated	A108
28	Gland Stud Nuts	Steel - Phos. Coated	A563 Gr. A
29	Handwheel Nut	Steel - Phos. Coated	A563 Gr. A
30	Identification Plate	Aluminum	
31	Disc - Disc Stem Ring Pin*	Steel	

\* Not shown

See page 5 for Pressure Temperature Ratings

#### Industry Standards

MSS SP-85, Type 1

### Dimensions and Weights

Inches (millimeters) - Pounds (kilograms)

Valve Size	Dimensions			WT
	B	C	M	
2	13.75	9.00	10.50	62
	(349)	(229)	(267)	(28)
2 ½	14.75	10.00	11.50	82
	(375)	(254)	(292)	(37)
3	16.50	10.00	12.50	118
	(419)	(254)	(318)	(54)
4	18.50	12.00	14.00	167
	(470)	(305)	(356)	(76)
6	23.25	16.00	17.50	320
	(591)	(406)	(445)	(145)
8	28.50	20.00	21.00	570
	(724)	(508)	(533)	(259)

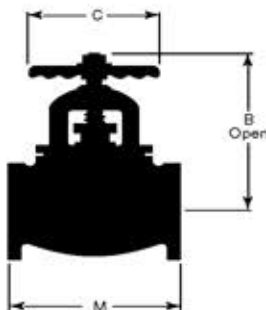

## Class 250 • Bolted Bonnet • OS&Y • Bronze Trim • Flanged

### 28E Stop Check Valve

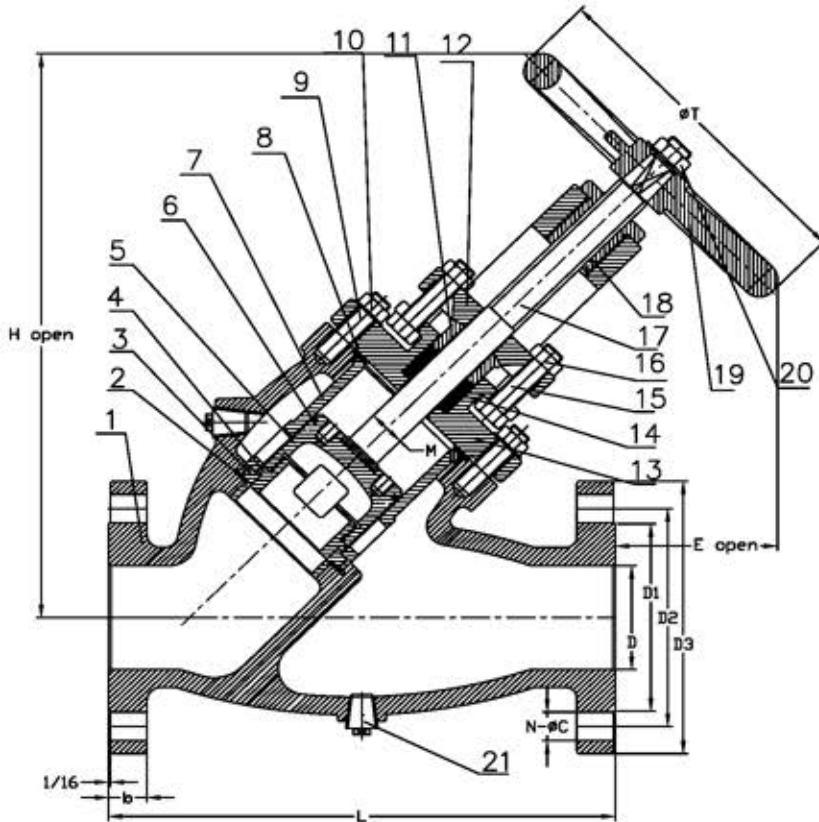

### Materials of Construction

No.	Description	Material	ASTM
1	Body	Ductile Iron	A536
2	Body Seat Gasket	Graphite	
3	Body Seat Ring	Cast Bronze	B62
4	Disc Seal	Cast Bronze	B62
5	Disc	Ductile Iron	A536
6	Piston Ring	Alloy Cast Iron	
7	Disc Guide	Ductile Iron	A536
8	Body Gasket	Graphite	
9	Bolts	Steel	A193 B7
10	Nuts	Steel	A194 2H
11	Packing Gland	Cast Brass	B62
12	Gland Follower	Ductile Iron	A536
13	Bonnet	Ductile Iron	A536
14	Packing	Die-formed Compressed Graphite	
15	Bolts	Steel	A193 B7
16	Nuts	Steel	A194 2H
17	Stem	Stainless Steel	410
18	Stem Nut	Cast Brass	B62
19	Handwheel	Cast Iron	A126 B
20	Nut	Steel	A194 2H
21	Drain Plug	Stainless Steel	304

See pages 23-26 for sizing and other Technical Data

NOTE: Contact your CRANE® representative if you wish to have basic flow calculations performed by CRANE® to advise the possible sizes appropriate for your application.

### Dimensions and Weights Inches (millimeters) - Pounds (kilograms)

#### Features:

- Valve designed for steam applications that operate between 100 and 250 psig.
- The Stop-Check feature of this valve requires a minimum of 50 psi pressure differential between piping system and boiler to operate properly.

Valve Size	Dimensions											WT
	D	D1	D2	D3	L	b	N - øC	M	H (Open)	E (Open)	T	
2 ½	2.50	4.94	5.86	7.50	13.00	1.00	8 - ø7/8	1.13	15.75	5.00	10.00	103
	(64)	(125)	(149)	(191)	(330)	(25)		(29)	(400)	(127)	(254)	(47)
3	3.00	5.69	6.63	8.25	14.75	1.13	8 - ø7/8	1.13	18.69	6.29	10.00	140
	(76)	(145)	(168)	(210)	(375)	(29)		(29)	(474)	(159)	(254)	(64)
4	4.00	6.31	7.86	10.00	17.00	1.25	8 - ø7/8	1.25	21.47	7.61	10.13	226
	(102)	(160)	(200)	(254)	(432)	(32)		(32)	(545)	(193)	(257)	(103)
5	5.00	8.31	9.25	11.00	19.00	1.38	8 - ø7/8	1.50	24.46	9.38	14.00	307
	(127)	(211)	(235)	(279)	(483)	(35)		(38)	(621)	(238)	(355)	(139)
6	6.00	9.69	10.63	12.50	21.50	1.44	12 - ø7/8	1.50	28.82	11.26	17.75	420
	(152)	(246)	(270)	(318)	(546)	(37)		(38)	(732)	(286)	(450)	(191)
8	8.00	11.94	13.00	15.00	26.00	1.63	12 - ø1	1.63	35.62	15.19	20.00	737
	(203)	(303)	(330)	(381)	(660)	(41)		(41)	(904)	(385)	(508)	(335)
10	10.00	14.06	15.25	17.50	30.00	1.88	-	1.75	-	-	-	1250
	(254)	(357)	(387)	(445)	(762)	(48)		(44)	-	-	-	(568)

#### Drain Plug Sizing Chart

2 1/2" - 6" Valves	1/2" NPT Plug
6" - 10" Valves	3/4" NPT Plug

### 30E Angle Stop Check Valve

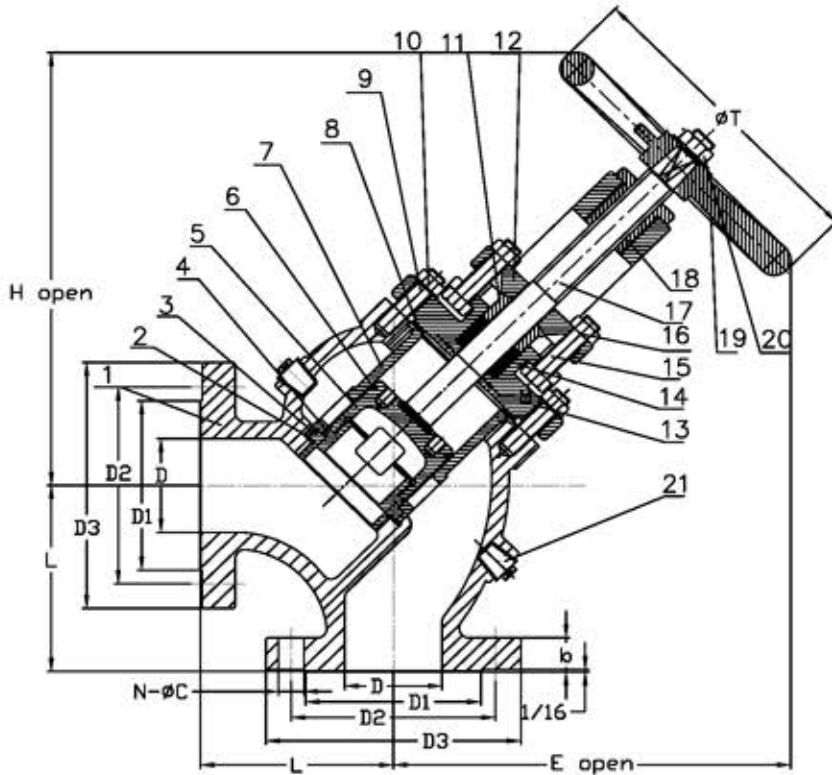

### Materials of Construction

No.	Description	Material	ASTM
1	Body	Ductile Iron	A536
2	Body Seat Gasket	Graphite	
3	Body Seat Ring	Cast Bronze	B62
4	Disc Seal	Cast Bronze	B62
5	Disc	Ductile Iron	A536
6	Piston Ring	Alloy Cast Iron	
7	Disc Guide	Ductile Iron	A536
8	Body Gasket	Graphite	
9	Bolts	Steel	A193 B7
10	Nuts	Steel	A194 2H
11	Packing Gland	Cast Brass	B62
12	Gland Follower	Ductile Iron	A536
13	Bonnet	Ductile Iron	A536
14	Packing	Die-formed Compressed Graphite	
15	Bolts	Steel	A193 B7
16	Nuts	Steel	A194 2H
17	Stem	Stainless Steel	410
18	Stem Nut	Cast Brass	B62
19	Handwheel	Cast Iron	A126 B
20	Nut	Steel	A194 2H
21	Drain Plug	Stainless Steel	304

See pages 23 - 26 for sizing and other Technical Data

NOTE: Contact your CRANE® representative if you wish to have basic flow calculations performed by CRANE® to advise the possible sizes appropriate for your application.

### Dimensions and Weights

Inches (millimeters) - Pounds (kilograms)

#### Features:

- Valve designed for steam applications that operate between 100 and 250 psig.
- The Stop-Check feature of this valve requires a minimum of 50 psi pressure differential between piping system and boiler to operate properly.

Drain Plug Sizing Chart	
2 1/2" - 6" Valves	1/2" NPT Plug
6" - 10" Valves	3/4" NPT Plug

Valve Size	Dimensions										WT	
	D	D1	D2	D3	L	b	N - øC	M	H (Open)	E (Open)		T
2 1/2	2.50	4.94	5.86	7.50	5.75	1.00	8 - ø7/8	1.13	13.87	12.85	10.00	86
	(64)	(125)	(149)	(191)	(146)	(25)		(29)	(352)	(326)	(254)	(39)
3	3.00	5.69	6.63	8.25	6.25	1.13	8 - ø7/8	1.13	16.00	14.37	10.00	123
	(76)	(145)	(168)	(210)	(159)	(29)		(29)	(406)	(364)	(254)	(55)
4	4.00	6.31	7.86	10.00	7.00	1.25	8 - ø7/8	1.25	18.00	15.71	10.13	186
	(102)	(160)	(200)	(254)	(178)	(32)		(32)	(457)	(399)	(257)	(84)
5	5.00	8.31	9.25	11.00	7.88	1.38	8 - ø7/8	1.50	21.35	18.67	14.00	250
	(127)	(211)	(235)	(279)	(200)	(35)		(38)	(542)	(474)	(355)	(113)
6	6.00	9.69	10.63	12.50	8.75	1.44	12 - ø7/8	1.50	24.76	21.93	17.75	340
	(152)	(246)	(270)	(318)	(222)	(37)		(38)	(628)	(557)	(450)	(154)
8	8.00	11.94	13.00	15.00	10.50	1.63	12 - ø1	1.63	32.79	28.26	20.00	640
	(203)	(303)	(330)	(381)	(267)	(41)		(41)	(832)	(717)	(508)	(291)
10	10.00	14.06	15.25	17.50	12.25	1.88	16 - ø1 1/8	1.75	33.98	29.25	20.00	1025
	(254)	(357)	(387)	(445)	(311)	(48)		(44)	(863)	(742)	(508)	(465)

# Technical Data Stop Check Valves

## Selecting the Proper Size Determining Pressure Drop

Since stop-check valves have a floating disc member, it is important that the valve be sized to provide full disc lift under flow conditions prevailing during the major portion of the service life. If the valve is too large, the disc will float in a partially open position and may cause fluttering of the disc and rapid wear.

Conversely, if the valve is too small, pressure drop will be excessive. The chart on the following page is a graphic presentation of flow data determined by test. Its use offers a simple method of determining the best size stop-check valve, as well as the pressure drop under varying conditions of flow, without any computation.

## How to Use the Chart Shown on the Following Page

**Given:** Steam Pressure-Temperature...250 psig 450°F  
Flow Rate...Typical Daily Demand Curve

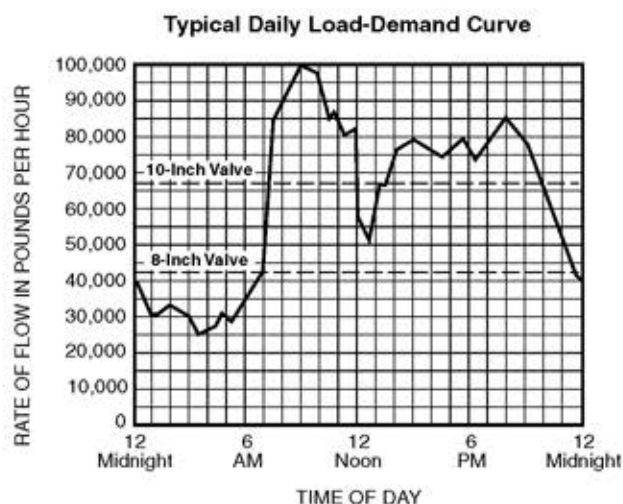

**Find:** Valve Catalog No. and the best size for above installation.

**Solution:**

1. Enter the Temperature chart at 450 °F. Move vertically upward to the curved line for 250 psi, then horizontally to the right to establish a point on the specific volume scale. From this point, draw a line through the flow rate being investigated (100,000 Lb/H) and establish a point on Index 1.

2. From that point, draw another line through the valve size, for example the 8-inch size, and establish a point on Index 2. Now move horizontally to the diagonal pressure drop line on the right side. Where these lines intersect, the pressure drop is 7.5 psi for the 8-inch, Class 250 globe valve and 8.5 psi for the 8-inch Class 250 angle valve.

Chart solutions resulting in a point on Index 2 that falls below the Line A-A for Class 250 valves indicate the disc will not be fully lifted under the flow conditions used. Operation under such conditions is not recommended but, at times, must be tolerated for short periods during the low loads.

3. Enter the chart where Line A-A intersects Index 2 for Class 250 valves. Move diagonally upward through the size being investigated (8-inch) and establish a second point on Index 1. From this point, extend a line to the specific volume established in Step 1 and at its intersection with the flow rate line, read 48,000 Lb/H as the minimum flow rate at which the disc will be in the fully lifted position. The pressure drop at this flow rate is 1.9 psi for globe and 2.1 psi for angle valves.

4. Repeat Steps 2 and 3 for other possible valve sizes, tabulate results, and make size selection on basis of pressure drop and duration of partial disc lift considerations.

Valve Size (Inches)	Press drop @ Max.Min. Flow rate (100,000 #/Hr.), psi		Flow Rate for Wide open valve #/Hr.
	Globe	Angle	
6	20.5	22.5	26,500
8	7.5	8.5	48,000
10	3.3	3.6	68,000

Dotted lines on Demand Curve indicate minimum flow rates for wide open 8" and 10" valves.

5. The best choice for this example would be the 10" size because pressure drop is much lower and duration of partially lifted disc is only slightly greater than for the 8" size.

6. Pressure drop for any intermediate flow condition can be determined as outlined in Steps 1 and 2.

7. Valves require a minimum of 50 psi differential pressure to seat the valve.

# Technical Data Y-Pattern Stop Check Valves

## CRANE® Bolted Bonnet Stop-Check Valves Selecting the Proper Size – Determining Pressure Drop

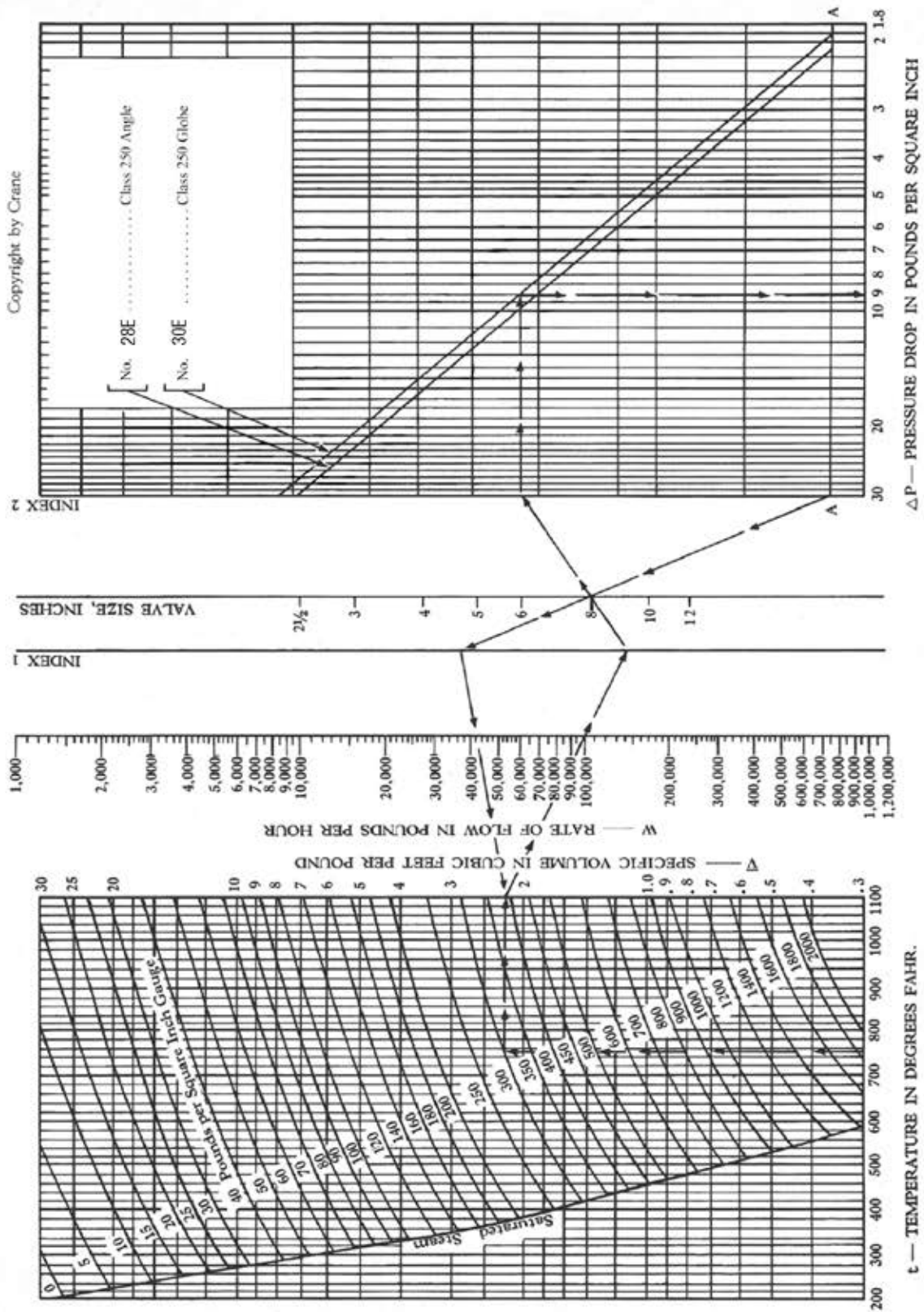



# Stop Check Sizing Information

**CRANE® STOP-CHECK VALVE SIZING INFORMATION REQUIRED**  
**Figure 28E Straight Through Y-Pattern**  
**Figure 30E Angle Y-Pattern**

**Minimum constant pressure of 100 psig required for valve to operate properly.**  
**Systems below 100 psig will not be possible to size**

Information required to properly size Stop-Check valves includes both minimum and maximum operating conditions.

**Maximum Operating Conditions**

Pressure: \_\_\_\_\_ psig Maximum  
 Temperature: \_\_\_\_\_ °F  
 Specific Volume: \_\_\_\_\_ cu. Ft/lbs (#a)  
 Flow Rate: \_\_\_\_\_ lbs/hr. Maximum

Customer: \_\_\_\_\_  
 Project: \_\_\_\_\_  
 Date: \_\_\_\_\_  
 Customer: \_\_\_\_\_  
 Phone #: \_\_\_\_\_  
 e-mail: \_\_\_\_\_

*(#a) We can obtain specific volume from steam table when provided with the temperature and pressure.*

**Minimum Operating Conditions**

Pressure: \_\_\_\_\_ psig Minimum  
 Temperature: \_\_\_\_\_ °F  
 Specific Volume: \_\_\_\_\_ cu. Ft/lbs (#a)  
 Flow Rate: \_\_\_\_\_ lbs/hr. Minimum

*(#a) We can obtain specific volume from steam table when provided with the temperature and pressure.*

In addition, valve installation orientation should be considered as well as the overall system of operation. Please keep in mind that our stop-check valves are metal seated and are a safety valve to prevent backflow. Since they are metal seated there is some allowable leakage rate per API-598. A minimum of 50-60 psi pressure differential is required for this valve to properly operate.

In order to properly run sizing calculations we require the flow rate (lbs/Hr.) thru the individual units (both minimum and maximum flows) along with the temperatures and pressures, again both minimum and maximums.

**Operating Conditions:**

Are all the valves on one boiler, or are they on separate boilers? \_\_\_\_\_  
 Are the boilers operated independently of each other, or are the units manifolded together to cycle between boilers?  
 Are the idle boilers allowed to fully depressurize, or are they maintaining a temperature/pressure in the standby boilers?  
 If so, what pressure/temperature is being maintained on standby and what is the operating system pressure?

As indicated in our literature, the CRANE® 28E can be operated in both a horizontal, and a vertical (upflow) line. The check valve feature should not be relied upon for primary shutoff.

The calculations are based upon temperatures, pressures, and flow rates provided. If there are significant fluctuations in any of these operating condition parameters than the units may not operate properly.

The reason we require information about stand-by mode on the boilers is because we have found that a significant number of end users have in the past several years changed their method of operation of multiple boilers. In the past the units would have been cycled between boilers and the non-active boiler allowed to totally de-pressurize and temperature normalize. More recently, we have seen a cycling program that keeps the stand-by unit with some temperature and with a significant pressure. When this method is used the stop-checks have a pressure on both sides of the piston/disc seal, causing the valves to not properly check.

# Installation Recommendations

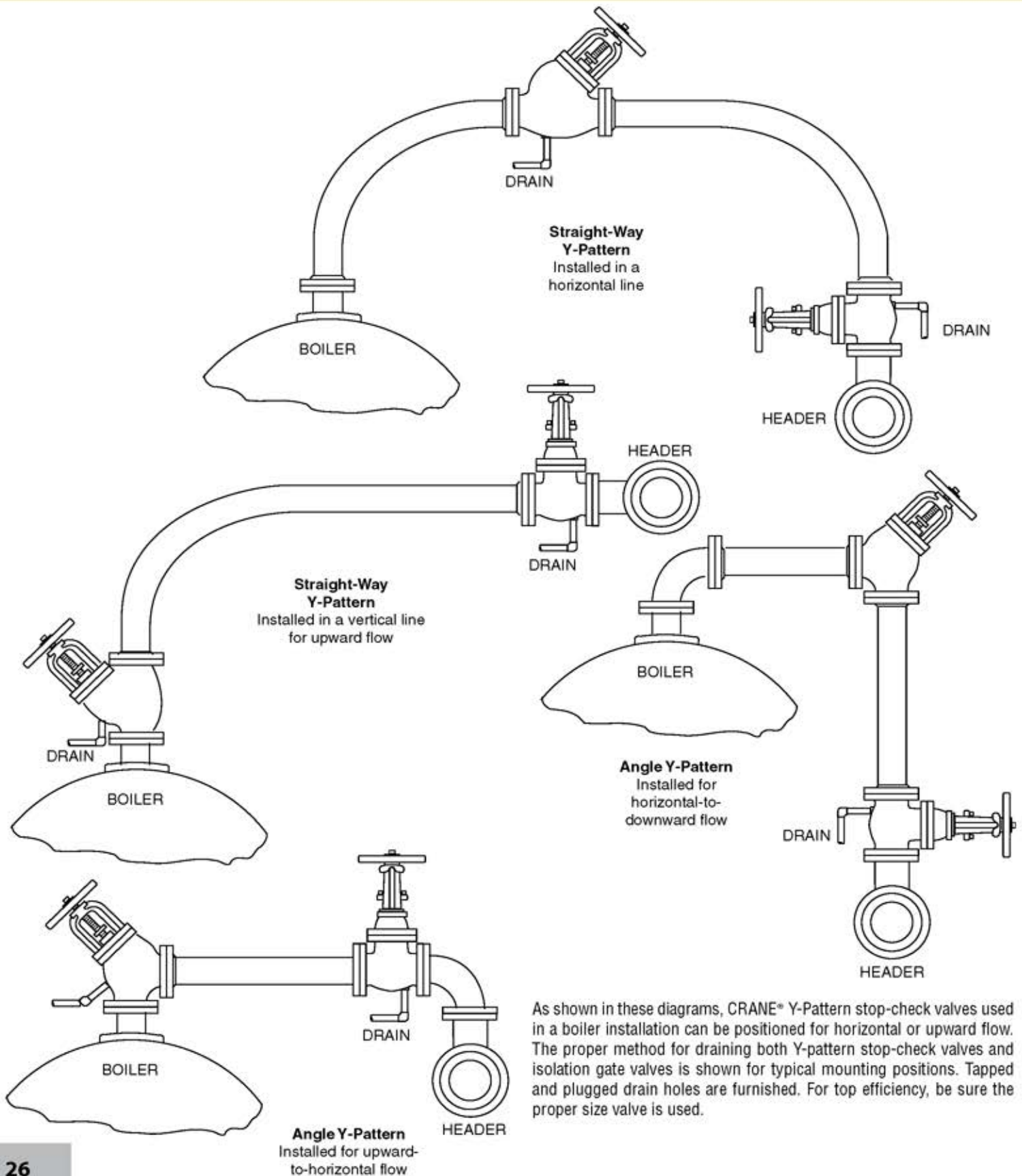

**Class 125 • Bolted Cap • Bronze Trim • Threaded Ends**

**372 Check Valve**

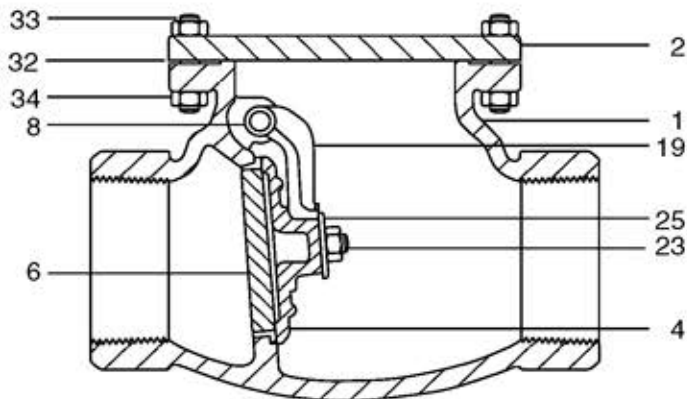

**Materials of Construction**

No.	Description	Material	ASTM
1	Body	Cast Iron	A126 Class B
2	Cap	Cast Iron	A126 Class B
4	Disc	Bronze	B62
6	Seat Ring	Bronze	B62
8	Hinge Pin	Alum Silicon Bronze	B150
19	Hinge	Bronze	B62
23	Disc Nut	Brass	B16
24	Side Plug*	Brass	B16
25	Disc Washer	Brass	B36
28	Hinge Pin Bushing*	Brass	B62
32	Bonnet Gasket	Aramid Fibers with SBR Binder	
33	Cap Bolt	Carbon Steel	A307 Gr. B
34	Cap Bolt Nut	Carbon Steel	A563 Gr. A
36	Identification Plate*	Aluminum	

\* Not shown  
See page 5 for Pressure Temperature Ratings

Industry Standards
MSS SP-71, Type 1

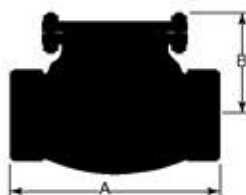

**Dimensions and Weights**  
Inches (millimeters) - Pounds (kilograms)

Valve Size	Dimensions		WT
	A	B	
2	6.12	4.50	18
	(155)	(114)	(8)
2 ½	7.25	5.38	22
	(184)	(137)	(10)
3	8.00	5.88	29
	(203)	(149)	(13)
4	9.25	6.62	54
	(235)	(168)	(25)

## Class 125 • Bolted Cap • Bronze Trim • Flanged Ends

### 373 Check Valve

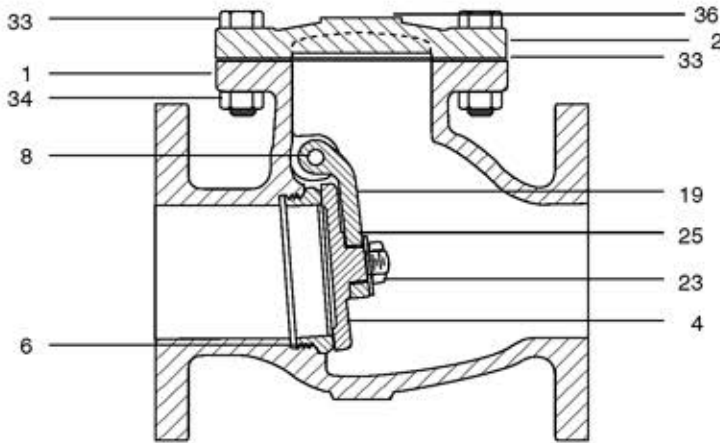

#### Dimensions and Weights Inches (millimeters) - Pounds (kilograms)

Valve Size	Dimensions		WT
	B	M	
2	4.50	8.00	25
	(114)	(203)	(11)
2 ½	5.38	8.50	30
	(137)	(216)	(14)
3	5.88	9.50	42
	(149)	(241)	(19)
4	6.62	11.50	74
	(168)	(292)	(33)
5	7.75	13.00	100
	(197)	(330)	(45)
6	8.25	14.00	125
	(210)	(356)	(56)
8	10.25	19.50	230
	(260)	(495)	(104)
10	12.00	24.50	490
	(305)	(622)	(219)
12	13.75	27.50	660
	(349)	(699)	(317)
14	15.50	31.00	794
	(393)	(787)	(360)
16	17.63	36.00	1020
	(447)	(914)	(462)
18	19.25	36.00	1304
	(610)	(914)	(591)
20	27.62	40.00	2590
	(702)	(1016)	(1117)
24	31	46.00	3840
	(787)	(1168)	(1745)

### Materials of Construction

No.	Description	Material	ASTM
1	Body	Cast Iron	A126 Class B
2	Cap	Cast Iron	A126 Class B
4	Disc	Bronze (2" - 6")	B584 C84400
		Cast Iron (8" - 24")	A126 Class B
6	Seat Ring	Bronze (2" - 12")	B584 C84400
		Bronze (14" - 24")	B584 C84400
7	Disc Ring	Bronze (8" - 12")	B584 C84400
		Bronze (14" - 24")	B584 C84400
8	Hinge Pin	Alum Silicon Bronze (2" - 8")	B150 C64200
		Naval Brass (10" - 12")	B21 C48200
		Stainless Steel (14" - 16")	
		Stainless Steel (18" - 24")	
19	Hinge	Bronze (2" - 6")	B584 C84400
		Ductile Iron (8" - 12")	A536 Gr. 65-45-12
		Ductile Iron (18" - 24")	A536 Gr. 65-45-12
		Carbon Steel (14" - 16")	
20	Disc Stud	Steel (8" - 16")	A108
		Steel (18" - 24")	A108
21	Disc Stud Pin	18-8 Stainless Steel (8" - 16")	
		Steel (18" - 24")	
23	Disc Nut	Brass (2" - 6")	B16 C36000
		Steel (8" - 24")	A563 Gr. A
24	Side Plug	Brass (2" - 16")	B16 C36000
		Ductile Iron (18" - 24")	A536 Gr. 65-45-12
25	Disc Washer	Brass (2" - 6")	B36
		Steel (8" - 16")	
26	Lockwasher*	Steel (18" - 24")	
27	Plain Washer*	Steel (18" - 24")	
28	Hinge Pin Bushing*	Brass (2" - 12")	B16 C36000
		Bronze (14" - 16")	
32	Bonnet Gasket	Aramid Fibers with SBR Binder	
33	Cap Bolt	Carbon Steel	A307 Gr. B
34	Cap Bolt Nut	Carbon Steel	A563 Gr. A
36	Identification Plate	Aluminum	

\* Not shown

See page 5 for Pressure Temperature Ratings

Industry Standards
Military Specification: MIL-V-18436
MSS SP-71, Type 1

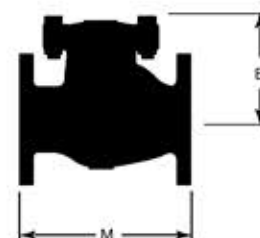

## Class 125 • Bolted Cap • Bronze Trim • Flanged Ends

### 383 Lever and Weight Check Valve

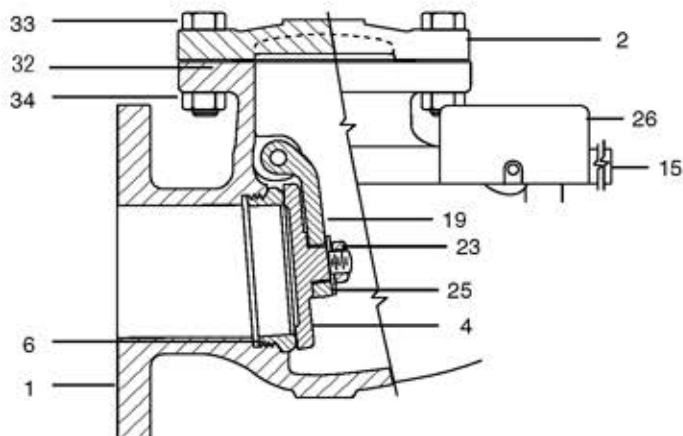

#### Dimensions and Weights Inches (millimeters) - Pounds (kilograms)

Valve Size	Dimensions		WT
	B	M	
2	4.50	8.00	30
	(114)	(203)	(14)
2 ½	5.38	8.50	40
	(137)	(216)	(18)
3	5.88	9.50	54
	(149)	(241)	(24)
4	6.62	11.50	85
	(168)	(292)	(38)
6	8.25	14.00	137
	(210)	(356)	(62)
8	10.25	19.50	240
	(260)	(495)	(108)
10	12.00	24.50	460
	(305)	(622)	(208)
12	13.75	27.50	700
	(349)	(699)	(317)
14	16.88	31.00	1060
	(429)	(787)	(481)
16	19.12	36.00	1500
	(486)	(914)	(682)
18	24.00	36.00	1970
	(610)	(914)	(895)
20	27.62	42.00	2590
	(702)	(1067)	(1117)
24	31.00	46.00	3840
	(787)	(1168)	(1745)

#### Materials of Construction

No.	Description	Material	ASTM
1	Body	Cast Iron	A126 Class B
2	Cap	Cast Iron	A126 Class B
4	Disc	Bronze (2" - 6")	B584 C84400
		Cast Iron (8")	A126 Class B
6	Body Seat Ring	Bronze	B584 C84400
7	Disc Seat Ring*	Bronze (8")	B584 C84400
8	Hinge Pin*†	Exelloy	A276 Type 410
11	Stuffing Box*†	Brass	B16 C36000
12	Packing*†	Braided Flexible Graphite with Corrosion Inhibitor	
14	Packing Nut*†	Bronze	B16 C36000
15	Lever†	Ductile Iron	A536 Gr. 65-45-12
19	Hinge†	Bronze (2" - 6")	B584 C84400
		Ductile Iron (8")	A536 Gr. 65-45-12
20	Disc Stud*	Steel (8")	A108
21	Disc Stud Pin*	18-8 Stainless Steel (8")	
22	Hinge Pin Key*†	Steel	A108
23	Nut for Disc	Brass (2" - 6")	B16 C36000
		(8") Steel	A563 Gr. A
24	Hinge Pin Plug*	Brass	B16 C36000
25	Disc Washer	Brass (2" - 6")	B36
		Steel (8")	
26	Weight†	Cast Iron	A126 Class B
27	Hinge Pin Bushing*	Bronze	B16 C36000
28	Lever Washer*†	Steel	
29	Coupling*†	Ductile Iron	A536 Gr. 65-45-12
30	Gib-Key*†	Steel	
31	Lever Nut*†	Steel Di-Chromate	
32	Gasket†	Aramid Fibers with SBR Binder	
33	Cap Bolts	Steel	A307 Gr. B
34	Cap Bolt Nuts	Steel	A563 Gr. A
36	ID Plate*	Aluminum	

\* Not shown

† Parts indicated are necessary for changing regular valve to outside lever and weight. See page 6 for Lever and Weight Technical Orientation Data

See page 5 for Pressure-Temperature Ratings

#### Industry Standards

MSS SP-71, Type 1

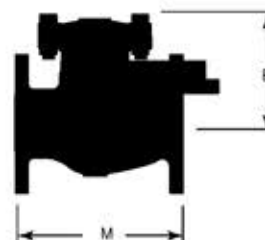

## Class 125 • Bolted Cap • All Iron • Flanged Ends

### 373 1/2 Check Valve

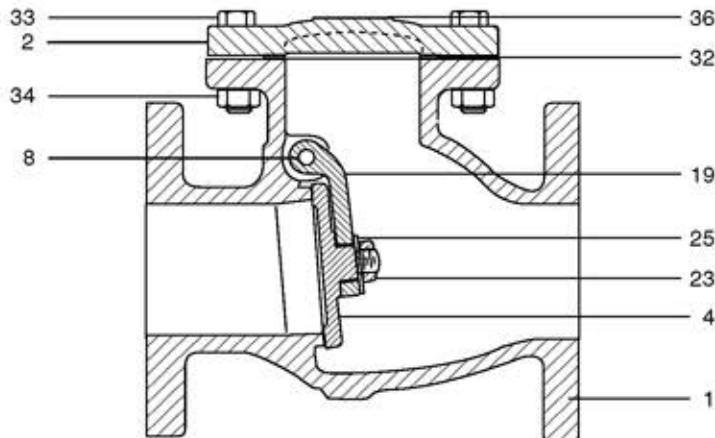

#### Dimensions and Weights Inches (millimeters) - Pounds (kilograms)

Valve Size	Dimensions		WT
	B	M	
2	4.50	8.00	25
	(114)	(203)	(11)
2 1/2	5.38	8.50	30
	(137)	(216)	(13)
3	5.88	9.50	42
	(149)	(241)	(19)
4	6.62	11.50	74
	(168)	(292)	(33)
5	7.75	13.00	100
	(197)	(330)	(45)
6	8.25	14.00	125
	(210)	(356)	(56)
8	10.25	19.50	230
	(260)	(495)	(104)
10	12.00	24.50	440
	(305)	(622)	(200)
12	13.75	27.50	660
	(349)	(699)	(299)
14	16.88	31.00	1060
	(429)	(787)	(481)
16	19.12	36.00	1500
	(486)	(914)	(682)
18	24.00	38.00	1970
	(610)	(965)	(895)
20	27.62	42.00	2590
	(702)	(1067)	(1117)
24	31.00	46.00	3840
	(787)	(1168)	(1745)

### Materials of Construction

No.	Description	Material	ASTM
1	Body	Cast Iron	A126 Class B
2	Cap	Cast Iron	A126 Class B
4	Disc	Ductile Iron (2" - 4")	A536 Gr. 65-45-12
		Cast Iron (6" - 24")	A126 Class B
6	Seat Ring*	Cast Iron (5", 10" - 24")	A126 Class B
		Cast Iron (2" - 4", 6" - 8") (Integral)	A126 Class B
8	Hinge Pin	Stainless Steel	A276 Type 410
19	Hinge	Ductile Iron	A536 Gr. 65-45-12
20	Disc Stud	Steel (8" - 16")	A108
		Steel (18" - 24")	A108
21	Disc Stud Pin	18-8 Stainless Steel (8" - 16")	
		Steel (18" - 24")	
23	Disc Nut	Steel (8" - 24")	A563 Gr. A
24	Side Plug*	Carbon Steel (2" - 12")	
		Ductile Iron (14" - 24")	A536 Gr. 65-45-12
25	Disc Washer	Carbon Steel (2" - 12")	
26	Lockwasher*	Steel (14" - 24")	
27	Plain Washer*	Steel (14" - 24")	
28	Hinge Pin Bushing*	Carbon Steel (2" - 12")	A108 Gr. 1018
32	Cap Gasket	Aramid Fibers with SBR Binder	
33	Cap Bolt	Carbon Steel	A307 Gr. B
34	Cap Bolt Nut	Carbon Steel	A563 Gr. A
36	Identification Plate	Aluminum	

\* Not shown

See page 5 for Pressure Temperature Ratings

#### Industry Standards

Military Specification: MIL-V-18436

MSS SP-71, Type 1

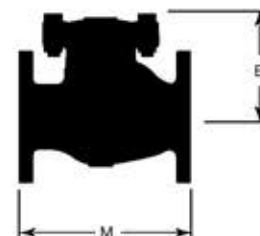

## Class 250 • Bolted Cap • Bronze Trim • Flanged Ends

### 39E Check Valve

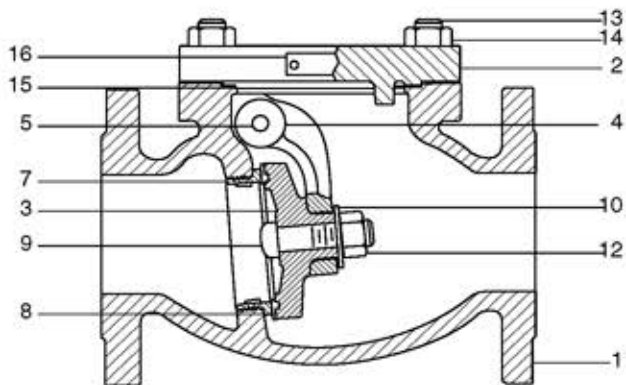

### Materials of Construction

No.	Description	Material	ASTM
1	Body	Cast Iron	A126 Class B
2	Cap	Cast Iron	A126 Class B
3	Disc	Bronze (2" - 3")	B584 C84400
		Cast Iron (4" - 8")	A126 Class B
4	Hinge	Ductile Iron	A536 Gr. 65-45-12
5	Hinge Pin	13 Cr. Stainless Steel (2" - 3")	A276 Type 410
		Bronze (4" - 8")	
6	Hinge Pin Plug*	Bronze	B16 C36000
7	Body Seat Ring	Bronze	B584 C84400
8	Disc Seat Ring	Bronze (4" - 8")	B584 C84400
9	Disc Bolt	Steel (4" - 8")	
10	Disc Nut Washer	Steel	
12	Disc Bolt Nut	Steel - Dichromate Fin.	
13	Cap Studs	Steel	A108
14	Cap Stud Nuts	Steel	A563 Gr. A
15	Gasket	Aramid Fibers with SBR Binder	
16	Identification Plate	Aluminum	

\* Not shown

See page 5 for Pressure Temperature Ratings

### Industry Standards

Military Specification: MIL-V-18436 Group B, Type 3, Trim 5  
MSS SP-71, Type 1

### Dimensions and Weights

Inches (millimeters) - Pounds (kilograms)

Valve Size	Dimensions		WT
	B	M	
2	5.25	10.50	46
	(133)	(267)	(21)
2 ½	6.00	11.50	64
	(152)	(292)	(29)
3	6.25	12.50	90
	(159)	(318)	(41)
4	7.25	14.00	133
	(184)	(356)	(60)
6	9.00	17.50	250
	(229)	(445)	(113)
8	11.00	21.00	410
	(279)	(533)	(185)

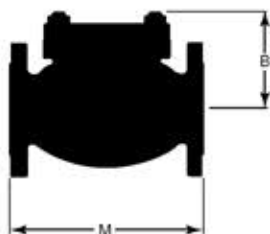

## Class 300 • Threaded Cap • Y-Pattern • All Iron • Threaded

### 346 1/2 Check Valve

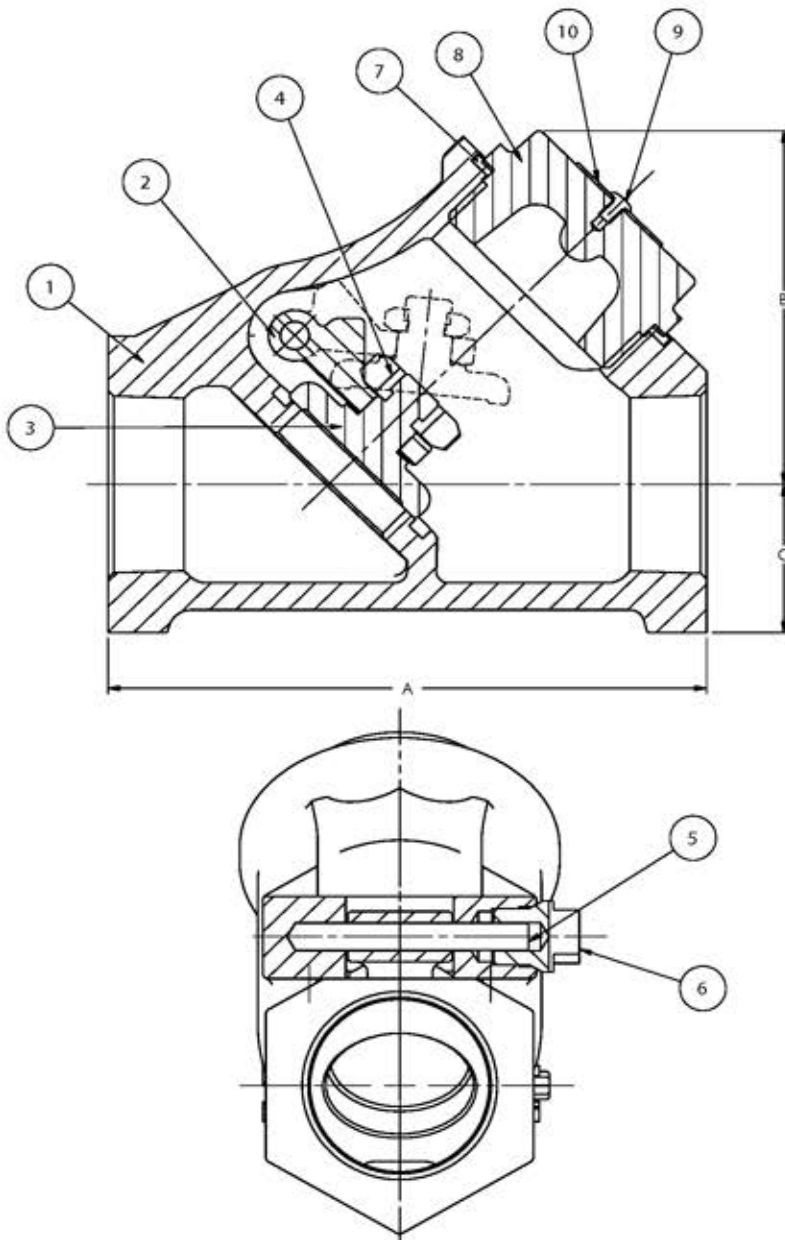

### Materials of Construction

No.	Description	Material	ASTM
1	Body	Ductile Iron	A536, 65-45-12
2	Hinge	Ductile Iron	A536, 65-45-12
3	Disc	Ductile Iron	A536, 65-45-12
4	Nut	Steel	A194 2H
5	Hinge Pin	Stainless Steel	AISI 410
6	Plug	Stainless Steel	AISI 304
7	Gasket	Aramid Fiber Blend with Nitrile Binder	
8	Bonnet Cap	Ductile Iron	A536, 65-45-12
9	Rivet	Steel	
10	ID Tag	Anodized Aluminum B&S Gauge #24	

### Industry Standards

MSS SP-71

ASME B1.20.1

### Dimensions and Weights Inches (millimeters) - Pounds (kilograms)

Valve Size	Dimensions			WT
	A	B	C	
1/2	2.75	1.69	1.06	1.34
	(70)	(43)	(27)	(.61)
3/4	3.27	1.90	1.06	1.67
	(83)	(48)	(27)	(.76)
1	4.06	2.45	1.06	2.50
	(103)	(62)	(27)	(1.11)
1 1/4	4.75	2.85	1.30	3.52
	(120)	(73)	(32)	(1.60)
1 1/2	5.40	3.29	1.40	5.42
	(137)	(84)	(36)	(2.46)
2	6.62	4.28	1.70	9.19
	(168)	(109)	(43)	(4.17)

Temperature Valve Ratings		Working Pressures, Non-shock, PSI	
°F	°C	PSI	kPa
-20 to 100	-30 to 37	640	4412
200	93	600	4136
300	149	565	3895
400	205	525	3619
500	260	495	3412
600	315	465	3206
650	343	450	3102









# CRANE®

CRANE ChemPharma & Energy

# FLOSOURCE

VALVES | ACTUATION | INSTRUMENTATION | STEAM SPECIALTIES

800-752-5959

sales@flosource.com



brands you trust.



CP\_EG-CR-CT-EN-L16-03-2013-11 (CV-302)

Crane Co., and its subsidiaries cannot accept responsibility for possible errors in catalogues, brochures, other printed materials, and website information. Crane Co. reserves the right to alter its products without notice, including products already on order provided that such alteration can be made without changes being necessary in specifications already agreed. All trademarks in this material are property of the Crane Co. or its subsidiaries. The Crane and Crane brands logotype, in alphabetical order, (ALOYCO®, CENTER LINE®, COMPAC-NOZ®, CRANE®, DEPA® & ELRO®, DUO-CHEK®, FLOWSEAL®, JENKINS®, KROMBACH®, NOZ-CHEK®, PACIFIC®, RESISTOFLEX®, REVO®, SAUNDERS®, STOCKHAM®, TRIANGLE®, UNI-CHEK®, VALVES®, WTA®, and XOMOX®) are registered trademarks of Crane Co. All rights reserved.