

**CRANE**<sup>®</sup>

brands you trust.



**FLOSCURCE**

VALVES | ACTUATION | INSTRUMENTATION | STEAM SPECIALTIES

**CRANE**

Energy Flow Solutions

CRANE<sup>®</sup> - Bronze Valves

[www.craneenergy.com](http://www.craneenergy.com)

## Key Features & Applications



### Key Features & Benefits

- ❶ Full Pressure Class offering: Class 125, Class 150, Class 200, Class 300, 200 CWP, and 300 CWP.
- ❷ Highly specified and proven performer for commercial and industrial piping applications.
- ❸ Wide option range seats, discs, trims, and connection type.

### Typical Applications

- General Services Plumbing
- Commercial Plumbing and HVAC
- Industrial Plumbing and HVAC
- Utility Applications
- Marine

# Bronze Valve Selection Guide & Figure Number Index

Cross Reference ..... 4  
 General Data ..... 5  
 Materials ..... 6  
 Ratings ..... 7  
 Pressure-Temperature Ratings and Flow Data ..... 8

CRANE® Figure No.	Catalog Page No.	Pressure Rating	Stem: RS or NRS	Bonnet/Cap: TB, UB, SC, UC	End Connections	Disc
<b>Bronze Gate Valves</b>						
428	9	Class 125	RS	TB	THD	SW
428UB	10	Class 125	RS	UB	THD	SW
438	11	Class 125	NRS	TB	THD	SW
1324	12	300 CWP	NRS	TB	SLD	SW
429	13	Class 150	NRS	TB	FLGD	SW
431	14	Class 150	RS	TB	THD	SW
431UB	15	Class 150	RS	UB	THD	SW
437	16	Class 150	NRS	TB	THD	SW
1320	17	200 CWP	NRS	TB	SLD	SW
1330	18	200 CWP	RS	TB	SLD	SW
422	19	Class 200	RS	UB	THD	SW
424	20	Class 200	RS	UB	THD	SW (SS Seat)
622E	21	Class 300	RS	UB	THD	SW
634E	22	Class 300	RS	UB	THD	SW (SS Seat)
636E	23	Class 300	NRS	UB	THD	SW (SS Seat)
<b>Bronze Globe Valves</b>						
1	24	Class 125	RS	TB	THD	BRZ
5TF	25	Class 125	RS	TB	THD	PTFE
7TF	26	Class 150	RS	UB	THD	PTFE
1310	27	300 CWP	RS	TB	SLD	PTFE
14 ½P	28	Class 150	RS	UB	THD	SS
212P	29	Class 200	RS	TB	THD	SS
88	30	Class 200	RS	TB	THD	Needle
382P	31	Class 300	RS	UB	THD	SS
<b>Bronze Angle Valves</b>						
17TF	32	Class 150	RS	UB	THD	PTFE
89	33	Class 200	RS	TB	THD	Needle
384P	34	Class 300	RS	UB	THD	SS
<b>Bronze Swing Check Valves: Y- Pattern</b>						
37	35	Class 125		SC	THD	BRZ
41TF	36	Class 125		SC	THD	PTFE
137	37	Class 150		SC	THD	BRZ
1342	38	300 CWP		SC	SLD	BRZ
141TF	39	Class 150		SC	THD	PTFE
36	40	Class 200		SC	THD	BRZ
1340	41	200 CWP		SC	SLD	BRZ
76E	42	Class 300		SC	THD	BRZ
<b>Bronze Lift Check Valves</b>						
27TF	43	Class 150		UC	THD	PTFE
366E	44	Class 300		UC	THD	BRZ
<b>Bronze Swing Check Valves: Horizontal Pattern</b>						
1707	45	Class 125		TB	THD	BRZ
1707S	46	200 CWP		TB	SLD	BRZ
<b>Bronze Lead Free Valves</b>						
LF438	48	200 CWP	NRS	TB	THD	SW
LF1320	49	200 CWP	NRS	TB	SLD	SW
LF1340	50	200 CWP			SLD	
LF37	51	200 CWP			THD	



## Cross Reference for Commonly Used Valves

### BRONZE VALVES

GATE	CRANE®	NIBCO	Milwaukee	Stockham®
Class 125 RS-Threaded	428	T-111	148	B-100
Class 125 NRS-Threaded	438	T-113	105	B-103
Class 125 RS-Solder	1330	S-111	149	B-108
Class 125 NRS-Solder	1320	S-113	115	B-104
Class 150 Union Bonnet	431UB	T-134	1151	B-120
Class 300 SS Trim	634E	T-174-SS	1184	B-145
GLOBE				
Class 125	1	T-211-B	502	B-16
Class 300 SS Trim	382P	T-275	593A	B-74
CHECK				
Class 125 Threaded	37	T-413-BY	509	B-319Y
Class 125 Solder	1340	S-413-B	1509	B-309Y
Class 300 Swing Check	76E	T-473-B	507	B-375
Class 300 Lift Check	366E	----	----	B-367

### IRON VALVES

GATE	CRANE®	NIBCO	Milwaukee	Powell	Walworth	Stockham®
Class 125 NRS	461	F-619	F2882 A	1787	W719F	G-612
Class 125 OS&Y	465 ½	F-617-0	F2885 A	1793	W726F	G-623
Class 250 OS&Y	7 ½E	F-667-0	F2894 A	1797	W786F	F-667
GLOBE						
Class 125	351	F-718-B	F2981 A	241	W906F	G-512
SWING CHECK						
Class 125	373	F-918-B	F2974 A	559	W928F	G-931
STOP CHECK						
Class 250 Straight-Way Y-Pattern	28E	----	-----	-----	----	F-540
Class 250 Angle Y-Pattern	30E	F-869-B	-----	-----	----	F-541

## General Data

Advanced manufacturing techniques and equipment, ongoing engineering research and product development, skilled craftsman, and over fourteen decades of experience in flow control are behind the quality and dependability built into every CRANE® product.

This catalog presents some of these products, namely: bronze gate, globe and check valves. The information is presented in a comprehensive manner and includes material, construction, rating, principal dimensions, and weight data.

### Hydrostatic and Shock Pressures

CRANE® valves are suitable for liquid working pressures specified on catalog pages only when used in hydraulic installations in which shock is absent or negligible. The sudden closure of a valve in a hydraulic system causes the body of liquid, which may be moving at a rate generally in excess of one foot per second, to stop instantaneously. As liquids are relatively incompressible, the sudden cessation of flow effects a rise in pressure considerably greater than the static working pressure. This pressure increase is termed "SHOCK" and may, in some cases, be sufficient to cause valves or piping to fail.

Pressure increase due to shock is not dependent upon the working pressure in the system but rather upon the velocity at which the liquid is flowing. This pressure surge severely limits design velocities; a fact readily understandable if it is remembered that pressure rise resulting from arrest of flow may be as high as 60 psi for each foot per second initial velocity. For example, installations of 100 psi and 1000 psi working pressures, with the same initial velocity of 10 feet per second, will be subject to the same increase in pressure (approximately 600 psi) due to instantaneous closure of a valve.

Shock generally prevails in lines equipped with check or quick-closing valves, or in lines supplied by reciprocating pumps. It may also be produced, to a lesser degree, by rapid closure of gate and globe valves. Therefore, care should be exercised when choosing valves installed in liquid lines.

Where shock is likely to occur, the maximum shock pressure should be added to the working pressure of the line to determine working pressure products in the line. In addition, hydraulic installations should be equipped with air chambers or other types of shock absorbers to eliminate, as much as possible, increase due to shock.

### Testing

Bronze valves described in this section meet or exceed the MSS SP-80 specifications for testing.

### Materials

The selection of materials for components of CRANE® valves is based upon expert metallurgical, engineering, foundry, and fabrication knowledge as well as on many years of usage experience. Considerations affecting materials of parts which come in contact with the conveyed fluid include pressure, temperature, and chemical composition of the fluid. The materials of moving parts that are subject to rubbing contact are selected on the basis of their resistance to wear, corrosion, seizing or galling, and on their frictional characteristics.

Utilization of materials to their full capability is assured by the use of stress analysis techniques that include extensive laboratory testing as well as the application of analytical theory. Stress levels for all materials used are maintained within the levels established by applicable codes, standards, and specifications.

### Illustrations & Weights

This catalog shows equivalent metric values to the customary imperial units. The "soft" conversion was found by following MSS SP-86 guidelines.

**Illustrations** – Catalog illustrations are representative of a certain size of each line of product but do not necessarily represent all sizes in all details.

**Material & design** – We reserve the right to institute changes in materials, designs, dimensions, and specifications without notice in keeping with our policy of continuing product development.

**Weights** – shown are approximate and are not guaranteed. They represent the average weight of CRANE® valves products as made from patterns in use at time weights were compiled.



## CRANE® Copper Alloys

CHEMICAL REQUIREMENTS (%) MECHANICAL PROPERTIES															
	Copper	Tin	Lead	Iron	Nickel	Manganese	Aluminum	Zinc	Silicon	Other	Tensile Strength		Yield Strength		Elongation
	Cu	Sn	Pb	Fe	Ni	Mn	Al	Zn	Si		ksi	MPa	ksi	MPa	(%)
<b>STEAM OR VALVE BRONZE CASTINGS</b>														<b>ASTM B61, C92200</b>	
Min.	86.0	5.5	1.0					3.0			34	235	16	110	24
Max.	90.0	6.5	2.0	0.25	1.0		0.005	5.0	0.005	0.05*					
<b>COMPOSITION BRONZE CASTINGS</b>														<b>ASTM B62, C83600</b>	
Min.	84.0	4.0	4.0					4.0			30	205	14	95	20
Max.	86.0	6.0	6.0	0.30	1.0		0.005	6.0	0.005	0.05*					
<b>COPPER-ZINC SILICON ALLOY ROD</b>														<b>ASTM B371, C69400</b>	
Min.	80.0							remainder	3.5		80	550	40	250	15
Max.	83.0		0.30	0.20					4.5						
<b>LEADED SEMI-RED BRASS</b>														<b>ASTM B584, C84400</b>	
Min.	78.0	2.3	6.0					7.0			29	200	13	90	18
Max.	82.0	3.5	8.0		1.0		0.005	10.0	0.005						
<b>SILICONE BRASS CASTINGS</b>														<b>ASTM B584, C87600</b>	
Min.	88.0							4.0	3.5		60	414	30	207	16
Max.			0.50					7.0	5.5						
<b>FREE CUTTING BRASS ROD/BAR</b>														<b>ASTM B16, C36000, H02</b>	
Min.	60.0		2.5					remainder			+	+	+	+	+
Max.	63.0		3.7	0.35						0.50**	+	+	+	+	+
<b>NAVAL BRASS ROD</b>														<b>ASTM B16, C48200, H02</b>	
Min.	59.0	0.5	0.4					remainder			+	+	+	+	+
Max.	62.0	1.0	1.0	0.15						0.10**	+	+	+	+	+
<b>ALUMINUM SILICONE BRONZE ROD</b>														<b>ASTM B150, C64200</b>	
Min.	87.5						6.3		1.5		+	+	+	+	+
Max.	92.5	0.20	0.05	0.30	0.25	0.10	7.6	0.50	2.2	0.50***	+	+	+	+	+
<b>LEADED RED BRASS CONTINUOUS CASTINGS</b>														<b>ASTM B505, C83600</b>	
Min.	84.0	4.0	4.0					4.0			36	248	19	131	15
Max.	86.0	6.0	6.0	0.30	1.0		0.005	6.0	0.005						
<b>BRASS PLATE/SHEET STRIP</b>														<b>ASTM B36, C26000, H04</b>	
Min.	68.5							remainder			71	489			
Max.	71.5		0.07	0.05							81	558			
<b>BRASS WIRE</b>														<b>ASTM B134, C26000, H02</b>	
Min.	68.5							remainder			57	395			
Max.	71.5		0.07	0.05							67	460			
<b>ALUMINUM SILICONE BRONZE FORGINGS</b>														<b>ASTM B283, C64200</b>	
Min.	88.7						6.3		1.5		+	+	+	+	+
Max.	90.1	0.20	0.05	0.30	0.25	0.10	7.6	0.50	2.2	0.15***	+	+	+	+	+
<b>COPPER SILICON ALLOY ROD/BAR</b>														<b>ASTM B98, C65100, H02</b>	
Min.	96.0								0.80		55	379	20	138	11
Max.			0.05	0.08		0.7		1.5	2.00						
<b>SEAMLESS COPPER WATER TUBE</b>														<b>ASTM B88, C12200</b>	
Min.	99.9										30	207			
Max.															

\* Also may include maximum of 0.05% phosphorus.

\*\* Maximum percent of elements permissible other than those indicated.

\*\*\* Also may include maximum of 0.15% arsenic.

+ Depends on diameter or thickness (surface to surface) of material: data on request.

# Introduction to Ratings

A) Ratings for Class 125, 150, 200, and 300 bronze valves are indicated on page 8 in this catalog:

- PSI Steam, Basic Rating; i.e., the nominal rated pressure of the valve.
- PSI Cold Working Pressure; i.e., the maximum rated pressure of the valve at a temperature range of -20° to 150°F (-30° to 65°C).

B) Ratings for Class 125 and 150 bronze valves equipped with non-metallic discs are indicated on the relevant catalog pages in this manner:

- PSI Saturated Steam; where "Saturated Steam" is the maximum rated pressure of the valve at the corresponding temperature of saturated steam.
- PSI Cold Working Pressure; where "Cold Working Pressure" is the maximum rated pressure of the valve at a temperature range of -20°F to 150°F (-30°C to 65°C).

The full range of allowable pressures and temperatures for these valves is determined by referring to the Pressure-Temperature charts shown on page 8.

C) Ratings for bronze valves falling outside Class 125, 150, 200, and 300 are indicated in various ways on the relevant catalog pages. The full range of allowable pressures and temperatures for these valves is determined by referring to the relevant catalog page.

**General**

All ratings represent the maximum allowable non-shock pressure at the indicated temperature. If the temperature is different from indicated, the allowable pressure may be interpolated.

**Rating Temperature**

The operating temperature of the valve is considered the temperature of the media flowing through it. This temperature must not exceed the maximum allowable temperature as stated in the Pressure-Temperature chart on page 8.

The safe Pressure-Temperature rating of a solder joint piping system is dependent, not only on valve, fitting, and tubing strength but also on the composition of the solder used for joints. It shall be the responsibility of the user to select a solder composition that is compatible with the service conditions.

The safe Pressure-Temperature rating of valves fitted with non-metallic discs (some Globe, Angle Valves and Check Valves) is dependent upon the composition of the disc material. It shall be the responsibility of the user to specify the service application. PTFE discs are suitable for a maximum service temperature of 400°F (200°C), nitrile composition discs are suitable for a maximum service temperature of 200°F (90°C).

## Adjusted Pressure-Temperature Ratings

Joints Made of Copper Tube and Solder End Valves (pounds per square inch) Extracted from MSS SP-80

Solder used in joints	Service Temperature Degrees F	Water, including other noncorrosive liquids and gases			Saturated Steam
		Valve Sizes			(psig)
		¼" - 1"	1 ¼" - 2"	2 ½" - 4"	Valves Sizes ¼" - 4"
50-50 Tin-Lead (ASTM B-32, Alloy Grade 50-A)	100	200	175	150	-
	150	150	125	100	-
	200	100	90	75	-
	250	85	75	50	15
95-5 Tin-Antimony	100	500	400	300	-
	150	400	350	275	-
	200	300	250	200	-
	250	200	175	150	15



## Pressure-Temperature Ratings

IMPERIAL UNITS						
Press. Class	125	150		200	300	
End Conn.	THD	THD	FLG	THD	THD**	FLG
Temp °F	PRESSURE - PSI NON-SHOCK					
	ASTM B-62			ASTM B-61		
-20 to 150	200	300	225	400	1000	600
200	185	270	210	375	920	560
250	170	240	195	350	830	525
300	155	210	180	325	740	490
350	140	180	165	300	650	450
400	-	-	-	275	560	410
406	125	150	150	-	-	-
450	120*	145*	-	250	480	375
500	-	-	-	225	390	340
550	-	-	-	200	300	300

METRIC UNITS						
Press. Class	125	150		200	300	
End Conn.	THD	THD	FLG	THD	THD**	FLG
Temp °C	PRESSURE - kPa NON-SHOCK					
	ASTM B-62			ASTM B-61		
-30 to 70	1380	2070	1550	2760	6890	4140
90	1280	1860	1450	2590	6340	3860
120	1170	1660	1340	2410	5720	3620
150	1070	1450	1240	2240	5100	3380
180	970	1240	1140	2070	4490	3100
200	-	-	-	1800	3860	2830
208	860	1030	1030	-	-	-
230	830*	1000*	-	1720	3310	2590
260	-	-	-	1550	2690	2340
290	-	-	-	1380	2070	2070

\* Some codes (i.e. ASME BPVC, Section 1) limit the rating temperatures of the indicated material to 406°F (208°C).

\*\* Alternative ratings for valve size 1/8" - 2" having threaded ends and union bonnet, when so indicated on the relevant catalogue pages.

### Technical Data: Flow Data (Cv Values)

The flow coefficient Cv expresses flow rate in usg per minute of water at 60°F, with 1.0 psi pressure drop across the valve.

Bronze Gate Valves	1/8"	1/4"	3/8"	1/2"	3/4"	1"	1 1/4"	1 1/2"	2"	2 1/2"	3"
All	-	8	8	16	36	60	90	140	270	470	680
Globe and Angle Valves											
17TF	-	1.6	3.1	5.1	9.2	16	28	39	66	-	-
382P	-	1.1	2.1	3.3	6.0	10	18	26	44	64	100
384P	-	1.5	3.0	4.9	9.0	15	27	38	64	-	-
1310	-	-	2.1	3.8	5.9	11	21	28	49	-	-
7TF, 14 1/2P, 212P	-	1.3	2.4	3.9	7.0	12	21	30	50	74	115
Check Valves											
29	-	1.3	2.5	4.1	7.6	13	23	31	54	78	125
27TF	-	0.9	1.8	3.0	5.4	9	16	22	39	-	-
366E	-	1.1	2.1	3.3	6.0	10	18	26	44	64	100
76E, 137, 1342, 141TF	-	2.3	4.3	7.2	13	22	39	56	92	135	215
Miscellaneous											
88, 89	0.3	0.6	1.1	1.9	3.4	-	-	-	-	-	-



**Class 125 • Threaded Bonnet • Rising Stem • Threaded Ends**

**428 Gate Valve**

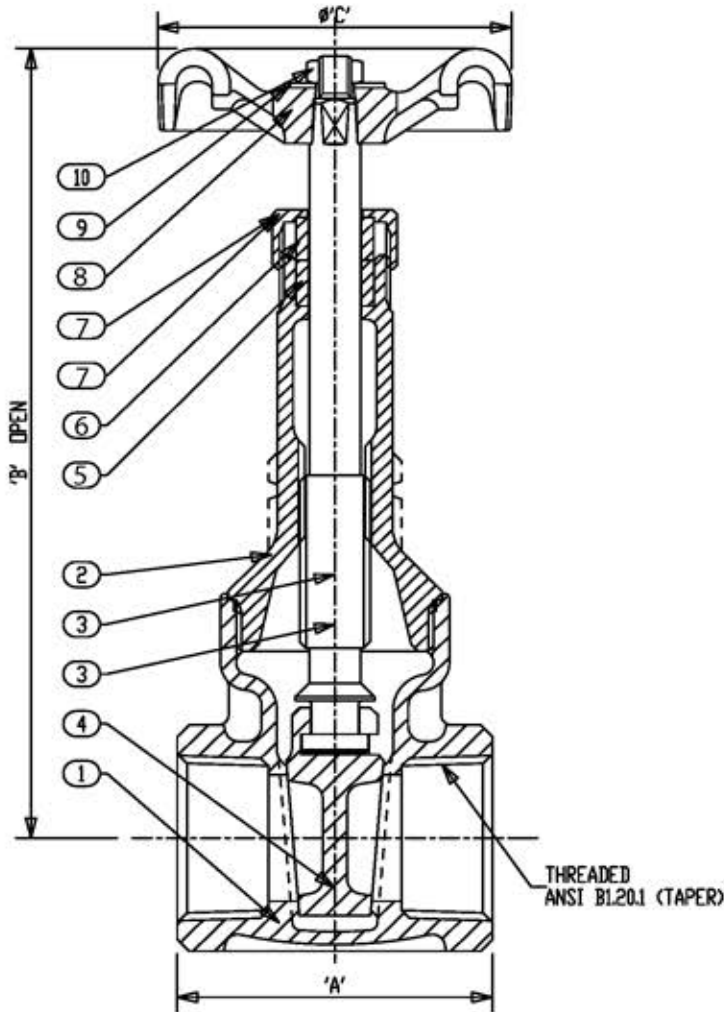

**Materials of Construction**

No.	Description	Material	ASTM Spec.
1	Body	Bronze	B-62 C83600
2	Bonnet	Bronze	B-62 C83600
3	Stem	Copper Silicon Bronze	B-371 69400
4	Disc	Bronze	B-62 C83600
5	Packing Ring	Graphite (Asbestos Free)	
6	Gland	Brass	BSEN12164 CW614N
7	Packing Nut	Brass	BSEN12164 CW614N
8	Handwheel	Malleable Iron	A-197 F22000
9	ID Plate	Aluminum	
10	Handwheel Nut	Brass	BSEN12164 CW614N

See page 8 for Pressure-Temperature Ratings.

**Industry Standards**

MSS SP-80, Type 2

**Dimensions and Weights**

Inches (millimeters) - Pounds (kilograms)

Valve Size	Dimensions			Wt.
	B	C	A	
¼	4.96	1.75	1.81	0.7
	(126)	(45)	(46)	(0.32)
⅜	4.96	1.75	1.81	0.7
	(126)	(45)	(46)	(0.31)
½	5.07	2.06	1.98	1.0
	(129)	(52)	(51)	(0.46)
¾	6.25	2.56	2.14	1.6
	(159)	(65)	(55)	(0.72)
1	7.44	2.75	2.46	2.4
	(189)	(70)	(63)	(1.10)
1 ¼	8.62	3.06	2.77	3.3
	(219)	(78)	(71)	(1.50)
1 ½	9.68	3.62	2.85	4.9
	(246)	(92)	(73)	(2.25)
2	11.85	3.62	3.25	7.0
	(301)	(92)	(83)	(3.20)
2 ½	14.53	5.28	4.25	12.8
	(369)	(134)	(108)	(5.80)
3	16.39	5.28	4.59	18.8
	(416)	(134)	(117)	(8.52)

## Class 125 • Union Bonnet\* • Rising Stem • Threaded Ends

### 428UB Gate Valve

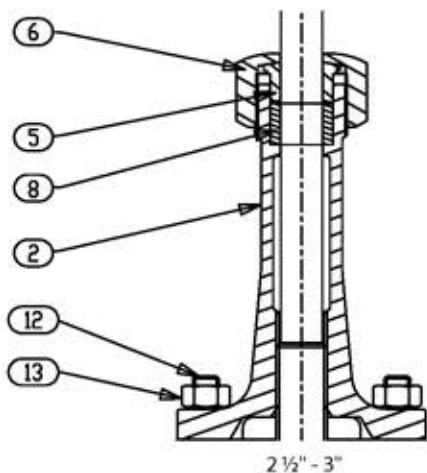
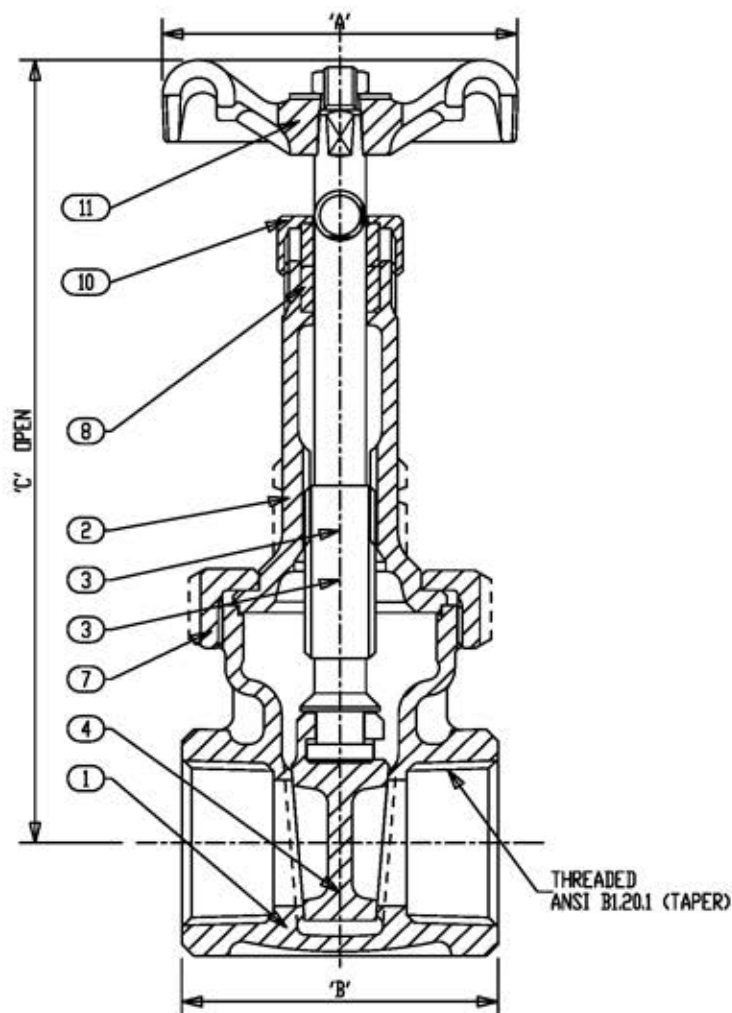

### Materials of Construction

No.	Description	Material	ASTM Spec.
1	Body	Bronze	B-62 C83600
2	Bonnet - Union	Bronze	B-62 C83600
3	Stem	Copper Silicon Bronze	B-371 C69400
4	Disc	Bronze	B-62 C83600
5	Gland	Brass	BSEN12164 CW614N
6	Packing Nut	Bronze	B-62 C83600
7	Union Ring	Bronze	B-62 C83600
8	Packing Ring	Graphite (Asbestos Free)	WRAS Listed & Approved
10	Packing Nut	(1/4" - 2") Brass	BSEN12164 CW614N
		(2 1/2" - 3") Bronze	B-62 C83600
11	Handwheel	Malleable Iron	A-197 F22000
12	Bonnet Stud	Phosphated Steel	BS970605M36 T & BS3189
13	Bonnet Nut	Phosphated Steel	BS4190 & BS3189
14	Gasket**	(2 1/2" - 3" only) Synthetic Glass Fiber Nitrile Filled	Klingsil C4500

\*\* Not Shown

See page 8 for Pressure-Temperature Ratings.

### Industry Standards

MSS SP-80, Type 2

### Dimensions and Weights

Inches (millimeters) - Pounds (kilograms)

Valve Size	Dimensions			Wt.
	C	A	B	
1/4	4.96	1.75	1.81	0.7
	(126)	(45)	(46)	(0.32)
3/8	4.96	1.75	1.81	0.7
	(126)	(45)	(46)	(0.31)
1/2	5.07	2.06	1.98	1.0
	(129)	(52)	(51)	(0.46)
3/4	6.25	2.56	2.14	1.6
	(159)	(65)	(55)	(0.72)
1	7.44	2.75	2.46	2.4
	(189)	(70)	(63)	(1.10)
1 1/4	8.62	3.06	2.77	3.3
	(219)	(78)	(71)	(1.50)
1 1/2	9.68	3.62	2.85	4.9
	(246)	(92)	(73)	(2.25)
2	11.85	3.62	3.25	7.0
	(301)	(92)	(83)	(3.20)
2 1/2	14.53	5.28	4.25	12.8
	(369)	(134)	(108)	(5.80)
3	16.39	5.28	4.59	18.8
	(416)	(134)	(117)	(8.52)

\* 2 1/2" and 3" have Bolted Bonnet



**Class 125 • Threaded Bonnet • Non-Rising Stem • Threaded Ends**

**438 Gate Valve**

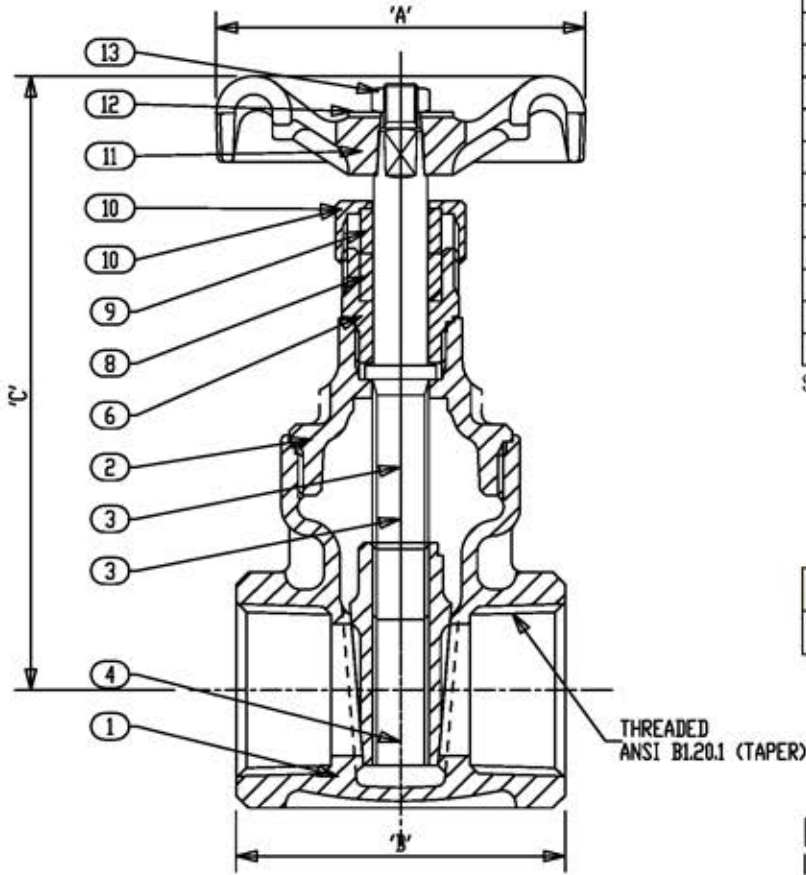

**Materials of Construction**

No.	Description	Material	ASTM Spec.
1	Body	Bronze	B-62 C83600
2	Bonnet	Bronze	B-62 C83600
3	Stem	Brass	B-371 69400
4	Disc	Bronze	B-62 C83600
6	Stuffing Box	Brass	B-371 69400
8	Packing Ring	Graphite (Asbestos Free)	
9	Gland	Brass	BSEN12164 CW614N
10	Packing Nut	Brass	BSEN12164 CW614N
11	Handwheel	Malleable Iron	A-197 F22000
12	ID Plate	Aluminum	
13	Handwheel Nut	Brass	BSEN12164 CW614N

See page 8 for Pressure-Temperature Ratings.

**Industry Standards**

MSS SP-80, Type 1

**Dimensions and Weights**

Inches (millimeters) - Pounds (kilograms)

Valve Size	Dimensions			Wt.
	C	A	B	
¼	2.95	1.75	1.81	0.6
	(75)	(45)	(46)	(0.27)
⅜	2.95	1.75	1.81	0.6
	(75)	(45)	(46)	(0.26)
½	3.23	2.06	1.98	0.8
	(82)	(52)	(51)	(0.35)
¾	3.74	2.56	2.14	1.2
	(95)	(65)	(55)	(0.55)
1	4.64	2.75	2.46	1.8
	(118)	(70)	(63)	(0.84)
1 ¼	5.67	3.06	2.77	2.6
	(144)	(79)	(71)	(1.18)
1 ½	6.53	3.62	2.85	3.6
	(166)	(92)	(73)	(1.66)
2	7.48	4.06	3.25	5.6
	(190)	(103)	(83)	(2.55)
2 ½	9.26	5.28	4.25	12.4
	(235)	(134)	(108)	(5.62)
3	9.89	5.28	4.59	17.4
	(251)	(134)	(117)	(7.89)

## 300 CWP • Threaded Bonnet • Non-Rising Stem • Solder Ends

### 1324 Gate Valve

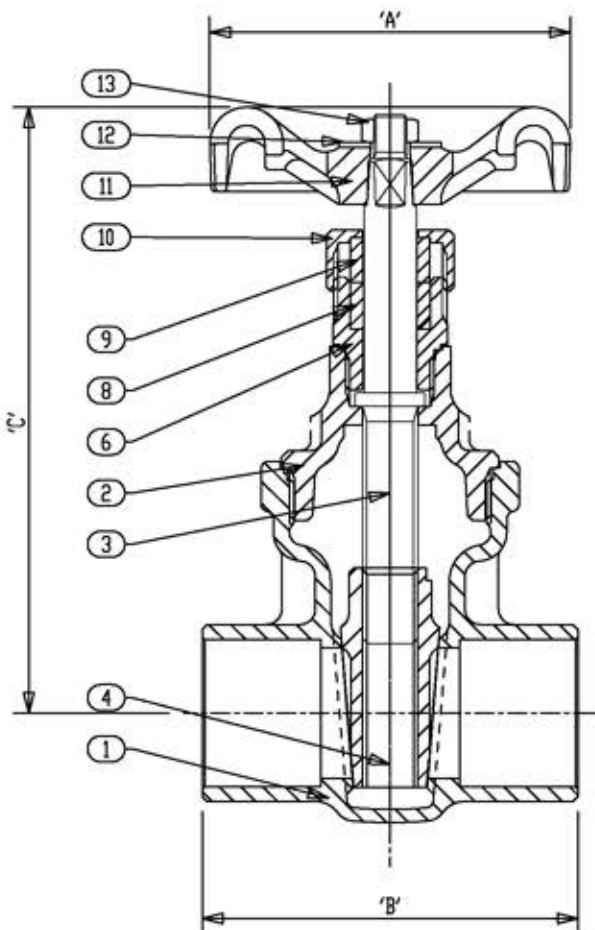

### Materials of Construction

No.	Description	Material	ASTM Spec.
1	Body	Bronze	B-62 C83600
2	Bonnet	Bronze	B-62 C83600
3	Stem	Copper Silicon Bronze	B-371 C69400
4	Disc	Bronze	B-62 C83600
6	Stuffing Box	Copper Silicon Bronze	B-371 C69400
8	Packing Ring	Graphite (Asbestos Free)	
9	Gland	Brass	BSEN12164 CW614N
10	Packing Nut	Brass	BSEN12164 CW614N
11	Handwheel	Malleable Iron	A-197 F22000
12	ID Plate	Aluminum	
13	Handwheel Nut	Brass	BSEN12164 CW614N

**Caution:** Before installing solder-joint valves, be sure solder or brazing alloy melting point is high enough to withstand line pressure, temperature conditions, and is compatible with fluid medium.

See page 7 for Adjusted Pressure-Temperature Ratings.

### Industry Standards

MSS SP-80, Type 1

### Dimensions and Weights

Inches (millimeters) - Pounds (kilograms)

Valve Size	Dimensions			Wt.
	A	B	C	
3/8	2.06	2.00	3.23	1.00
	(52)	(48)	(82)	(0.47)
1/2	2.56	2.20	3.74	1.30
	(65)	(61)	(95)	(0.60)
3/4	2.75	2.50	4.64	2.00
	(70)	(73)	(118)	(.92)
1	3.06	2.80	5.67	3.10
	(79)	(79)	(144)	(1.41)
1 1/4	3.62	2.90	6.53	4.20
	(92)	(88)	(166)	(1.92)
1 1/2	4.06	3.30	7.48	6.00
	(103)	(105)	(190)	(2.72)
2	5.28	4.30	9.26	12.40
	(134)	(112)	(235)	(5.62)
2 1/2	5.28	4.60	9.89	17.40
	(134)	(126)	(251)	(7.89)
3	5.35	12.83	5.12	15.10
	(136)	(326)	(130)	(6.82)



**Class 150 • Threaded Bonnet • Non-Rising Stem • Flanged Ends**

**429 Gate Valve**

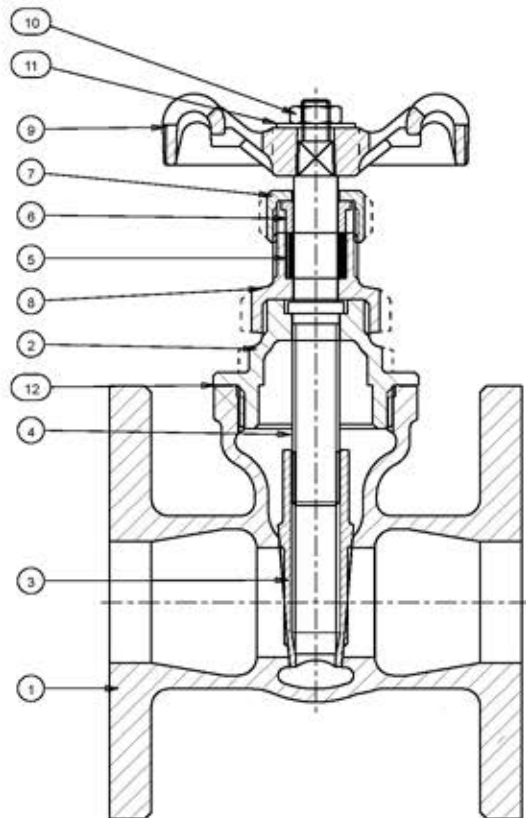

**Materials of Construction**

No.	Description	Material	ASTM Spec.
1	Body	Bronze	B-62 C83600
2	Bonnet	Bronze	B-62 C83600
3	Disc	Bronze	B-62 C83600
4	Stem	Copper Silicon Bronze	B-371 C69400
5	Packing	Graphite (Asbestos Free)	
6	Gland	Brass	BSEN12164 CW614N
7	Packing Nut	Brass	BSEN12164 CW614N
8	Stem Bush	(1" Copper Silicon Bronze	B-371 C69400
8	Stuffing Box	(1 1/4" - 2" Copper Silicon Bronze (2 1/2" - 3" Bronze	B-371 C69400 B-62 C83600
9	Handwheel	Malleable Iron	A-197 F22000
10	Handwheel Nut	Brass	BSEN12164 CW614N
11	ID Plate	Aluminum	
12	Gasket	(3" only) Synthetic Glass Fiber Nitrile Filled	

See page 8 for Pressure-Temperature Ratings.

<b>Industry Standards</b>
MSS SP-80, Type 1

**Dimensions and Weights**

Inches (millimeters) - Pounds (kilograms)

Valve Size	Dimensions			Wt.
	B	C	M	
1	4.88	2.75	3.90	5.71
	(124)	(70)	(99)	(2.59)
1 1/4	5.71	3.63	4.33	6.31
	(145)	(92)	(110)	(2.86)
1 1/2	6.50	3.63	4.72	9.04
	(165)	(92)	(120)	(4.10)
2	7.44	4.06	5.32	12.33
	(189)	(103)	(135)	(5.54)
2 1/2	9.13	4.75	6.50	18.50
	(232)	(121)	(165)	(8.39)
3	10.39	6.00	7.28	25.50
	(264)	(152)	(185)	(11.60)

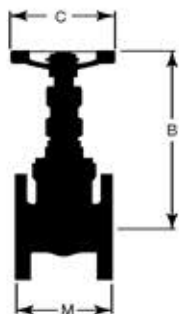

## Class 150 • Threaded Bonnet • Rising Stem • Threaded Ends

### 431 Gate Valve

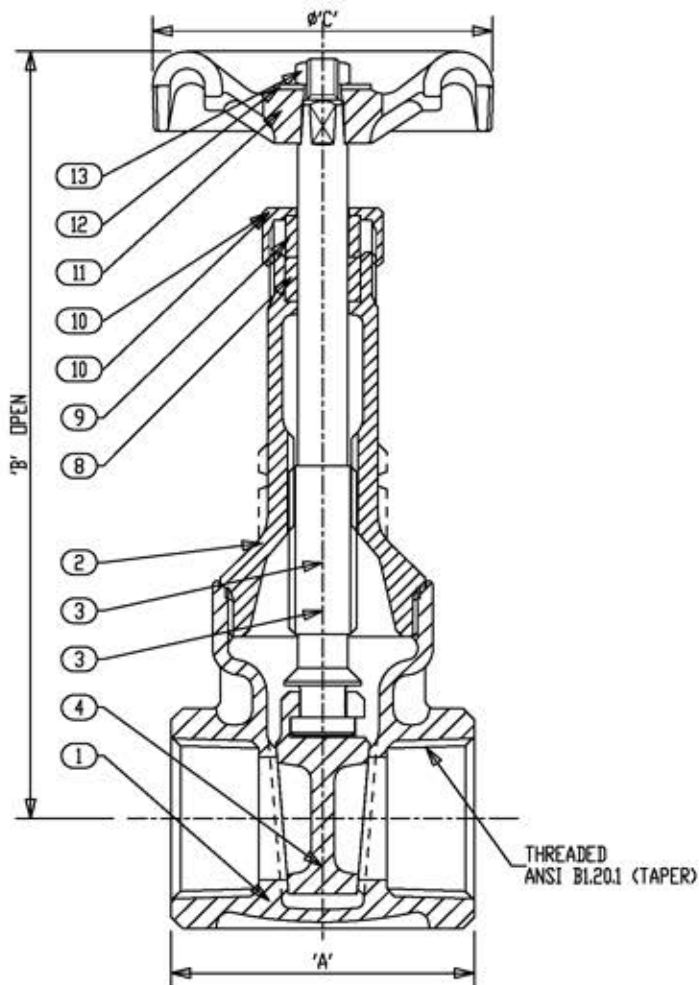

### Materials of Construction

No.	Description	Material	ASTM Spec.
1	Body	Bronze	B-62 C83600
2	Bonnet	Bronze	B-62 C83600
3	Stem	Copper Silicon Bronze	B-371 C69400
4	Disc	Bronze	B-62 C83600
8	Packing Ring	Graphite (Asbestos Free)	
9	Gland	Brass	BSEN12164 CW614N
10	Packing Nut	Brass	BSEN12164 CW614N
11	Handwheel	Malleable Iron	A-197 F22000
12	ID Plate	Aluminum	
13	Handwheel Nut	Brass	BSEN12164 CW614N

See page 8 for Pressure-Temperature Ratings.

### Industry Standards

MSS SP-80, Type 2

### Dimensions and Weights

Inches (millimeters) - Pounds (kilograms)

Valve Size	Dimensions			Wt.
	B	C	A	
¼	4.96	1.75	1.81	0.7
	(126)	(45)	(46)	(0.32)
⅜	4.96	1.75	1.81	0.7
	(126)	(45)	(46)	(0.32)
½	5.07	2.06	1.98	1.0
	(129)	(52)	(51)	(0.46)
¾	6.25	2.56	2.14	1.6
	(159)	(65)	(55)	(0.72)
1	7.44	2.75	2.46	2.4
	(189)	(70)	(63)	(1.10)
1 ¼	8.62	3.06	2.77	3.3
	(219)	(78)	(71)	(1.50)
1 ½	9.68	3.62	2.85	4.9
	(246)	(92)	(73)	(2.25)
2	11.85	3.62	3.25	7.0
	(301)	(92)	(83)	(3.20)
2 ½	14.53	5.28	4.25	12.8
	(369)	(134)	(108)	(5.80)
3	16.39	5.28	4.59	18.8
	(416)	(134)	(117)	(8.52)



**Class 150 • Union Bonnet\* • Rising Stem • Threaded Ends**

**431UB Gate Valve**

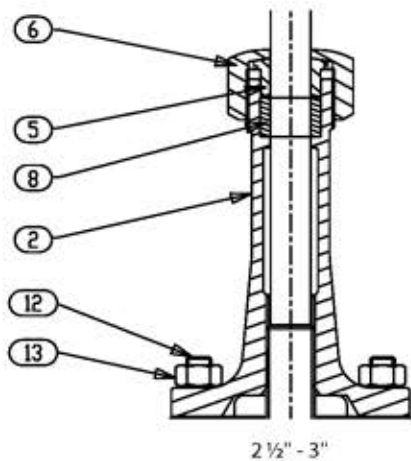
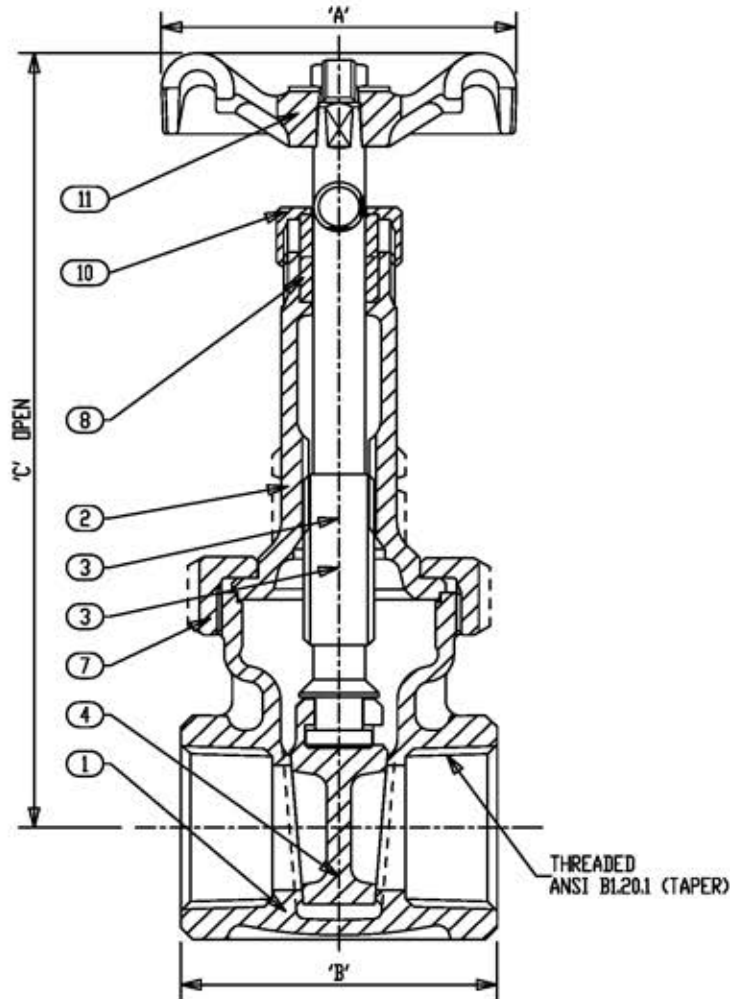

**Materials of Construction**

No.	Description	Material	ASTM Spec.
1	Body	Bronze	B-62 C83600
2	Bonnet - Union	Bronze	B-62 C83600
3	Stem	Copper Silicon Bronze	B-371 C69400
4	Disc	Bronze	B-62 C83600
5	Gland	Brass	BSEN12164 CW614N
6	Packing Nut	Bronze	B-62 C83600
7	Union Ring	Bronze	B-62 C83600
8	Packing Ring	Graphite (Asbestos Free)	WRAS Listed & Approved
10	Packing Nut	(1/4" - 2") Brass (2 1/2" - 3") Bronze	BSEN12164 CW614N B-62 C83600
11	Handwheel	Malleable Iron	A-197 F22000
12	Bonnet Stud	Phosphated Steel	BS970605M36 T & BS3189
13	Bonnet Nut	Phosphated Steel	BS4190 & BS3189
14	Gasket**	(2 1/2" - 3" only) Synthetic Glass Fiber Nitrile Filled	Klingsil C4500

\*\* Not Shown

See page 8 for Pressure-Temperature Ratings.

**Industry Standards**

MSS SP-80, Type 2

**Dimensions and Weights**

Inches (millimeters) - Pounds (kilograms)

Valve Size	Dimensions			Wt.
	C	A	B	
1/4	4.96	1.75	1.81	0.7
	(126)	(45)	(46)	(0.32)
3/8	4.96	1.75	1.81	0.7
	(126)	(45)	(46)	(0.31)
1/2	5.07	2.06	1.98	1.0
	(129)	(52)	(51)	(0.46)
3/4	6.25	2.56	2.14	1.6
	(159)	(65)	(55)	(0.72)
1	7.44	2.75	2.46	2.4
	(189)	(70)	(63)	(1.10)
1 1/4	8.62	3.06	2.77	3.3
	(219)	(78)	(71)	(1.50)
1 1/2	9.68	3.62	2.85	4.9
	(246)	(92)	(73)	(2.25)
2	11.85	3.62	3.25	7.0
	(301)	(92)	(83)	(3.20)
2 1/2	14.53	5.28	4.25	12.8
	(369)	(134)	(108)	(5.80)
3	16.39	5.28	4.59	18.8
	(416)	(134)	(117)	(8.52)

\* 2 1/2" and 3" have Bolted Bonnet

## Class 150 • Threaded Bonnet • Non-Rising Stem • Threaded Ends

### 437 Gate Valve

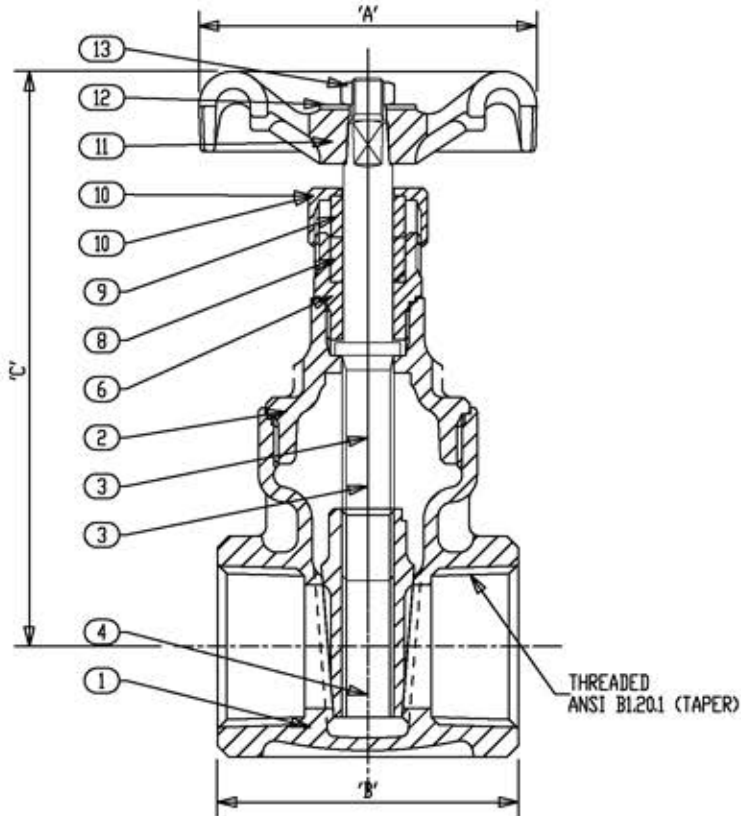

### Materials of Construction

No.	Description	Material	ASTM Spec.
1	Body	Bronze	B-62 C83600
2	Bonnet	Bronze	B-62 C83600
3	Stem	Copper Silicon Bronze	B-371 C69400
4	Disc	Bronze	B-62 C83600
6	Stuffing Box	Brass	B-371 C69400
8	Packing Ring	Graphite (Asbestos Free)	
9	Gland	Brass	BSEN12164 CW614N
10	Packing Nut	Brass	BSEN12164 CW614N
11	Handwheel	Malleable Iron	A-197 F22000
12	ID Plate	Aluminum	
13	Handwheel Nut	Brass	BSEN12164 CW614N

See page 8 for Pressure-Temperature Ratings.

### Industry Standards

MSS SP-80, Type 1

### Dimensions and Weights

Inches (millimeters) - Pounds (kilograms)

Valve Size	Dimensions			Wt.
	C	A	B	
¼	2.95	1.75	1.81	0.6
	(75)	(45)	(46)	(0.27)
⅜	2.95	1.75	1.81	0.6
	(75)	(45)	(46)	(0.26)
½	3.23	2.06	1.98	0.8
	(82)	(52)	(51)	(0.35)
¾	3.74	2.56	2.14	1.2
	(95)	(65)	(55)	(0.55)
1	4.64	2.75	2.46	1.8
	(118)	(70)	(63)	(0.84)
1 ¼	5.67	3.06	2.77	2.6
	(144)	(79)	(71)	(1.18)
1 ½	6.53	3.62	2.85	3.6
	(166)	(92)	(73)	(1.66)
2	7.48	4.06	3.25	5.6
	(190)	(103)	(83)	(2.55)
2 ½	9.26	5.28	4.25	12.4
	(235)	(134)	(108)	(5.62)
3	9.89	5.28	4.59	17.4
	(251)	(134)	(117)	(7.89)



**200 CWP • Threaded Bonnet • Non-Rising Stem • Solder Ends**

**1320 Gate Valve**

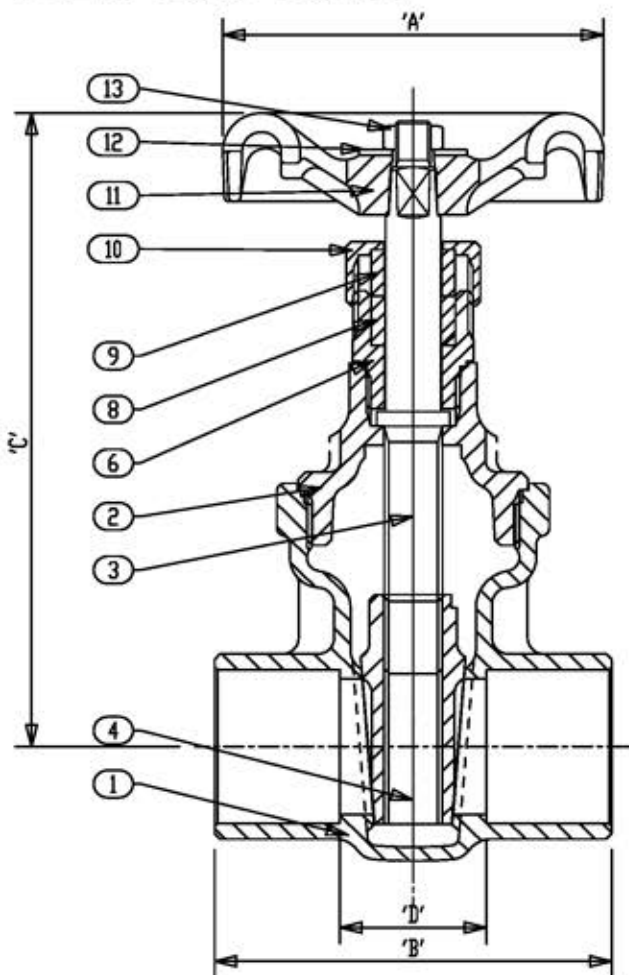

**Materials of Construction**

No.	Description	Material	ASTM Spec.
1	Body	Bronze	B-62 C83600
2	Bonnet	Bronze	B-62 C83600
3	Stem	Copper Silicon Bronze	B-371 C69400
4	Disc	Bronze	B-62 C83600
6	Stuffing Box	Copper Silicon Brass	B-124 C37700
8	Packing Ring	Graphite (Asbestos Free)	
9	Gland	Brass	BSEN12164 CW614N
10	Packing Nut	Brass	BSEN12164 CW614N
11	Handwheel	Malleable Iron	A-197 F22000
12	ID Plate	Aluminum	
13	Handwheel Nut	Brass	BSEN12164 CW614N

**Caution:** Before installing solder-joint valves, be sure solder or brazing alloy melting point is high enough to withstand line pressure, temperature conditions, and is compatible with fluid medium.

See page 7 for Adjusted Pressure-Temperature Ratings.

**Industry Standards**

MSS SP-80, Type 1

**Dimensions and Weights**

Inches (millimeters) - Pounds (kilograms)

Valve Size	Dimensions				Wt.
	C	A	D*	B	
½	3.23	2.06	0.81	2.00	1.0
	(82)	(52)	(21)	(48)	(0.47)
¾	3.74	2.56	0.86	2.20	1.3
	(95)	(65)	(23)	(62)	(0.60)
1	4.64	2.75	1.04	2.50	2.0
	(118)	(70)	(27)	(73)	(0.92)
1 ¼	5.67	3.06	1.18	2.80	3.1
	(144)	(79)	(30)	(79)	(1.41)
1 ½	6.53	3.62	1.22	2.90	4.2
	(166)	(92)	(31)	(88)	(1.92)
2	7.48	4.06	1.42	3.30	6.0
	(190)	(103)	(36)	(105)	(2.72)
2 ½	9.26	5.28	1.44	4.30	12.4
	(235)	(134)	(37)	(112)	(5.62)
3	9.89	5.28	1.57	4.60	17.4
	(251)	(134)	(40)	(126)	(7.89)

\*Piping Make-Up Dimensions

## 200 CWP • Threaded Bonnet • Rising Stem • Solder Ends

### 1330 Gate Valve

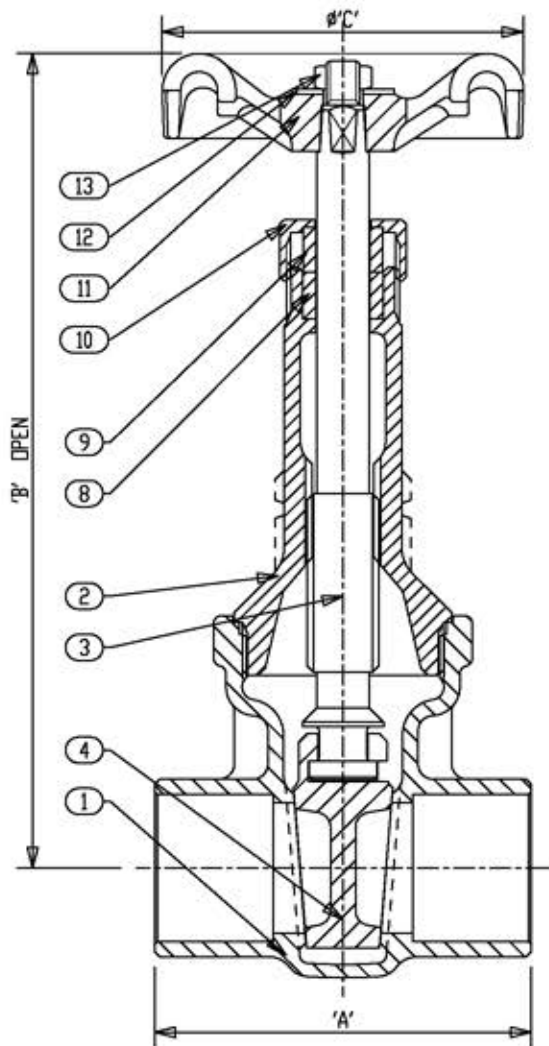

### Materials of Construction

No.	Description	Material	ASTM Spec.
1	Body	Bronze	B-62 C83600
2	Bonnet	Bronze	B-62 C83600
3	Stem	Copper Silicon Bronze	B-371 C69400
4	Disc	Bronze	B-62 C83600
8	Packing Ring	Graphite (Asbestos Free)	
9	Gland	Brass	BSEN12164 CW614N
10	Packing Nut	Brass	BSEN12164 CW614N
11	Handwheel	Malleable Iron	A-197 F22000
12	ID Plate	Aluminum	
13	Handwheel Nut	Brass	BSEN12164 CW614N

Caution: Before installing solder-joint valves, be sure solder or brazing alloy melting point is high enough to withstand line pressure, temperature conditions, and is compatible with fluid medium.

See page 7 for Adjusted Pressure-Temperature Ratings.

### Industry Standards

MSS SP-80, Type 2

### Dimensions and Weights

Inches (millimeters) - Pounds (kilograms)

Valve Size	Dimensions			Wt.
	A	B	C	
½	2.00	5.07	2.06	1.00
	(48)	(129)	(52)	(0.46)
¾	2.20	6.25	2.56	1.60
	(61)	(159)	(65)	(0.72)
1	2.50	7.44	2.75	2.40
	(73)	(189)	(70)	(1.10)
1 ¼	2.80	8.62	3.06	3.30
	(79)	(219)	(78)	(1.50)
1 ½	2.90	9.68	3.62	4.90
	(88)	(246)	(92)	(2.25)
2	3.30	11.85	3.62	7.00
	(105)	(301)	(92)	(3.20)
2 ½	4.30	14.53	5.28	12.80
	(112)	(369)	(134)	(5.80)
3	4.60	16.39	5.28	18.80
	(126)	(416)	(134)	(8.52)

**Class 200 • Union Bonnet\* • Rising Stem • Threaded Ends**

**422 Gate Valve**

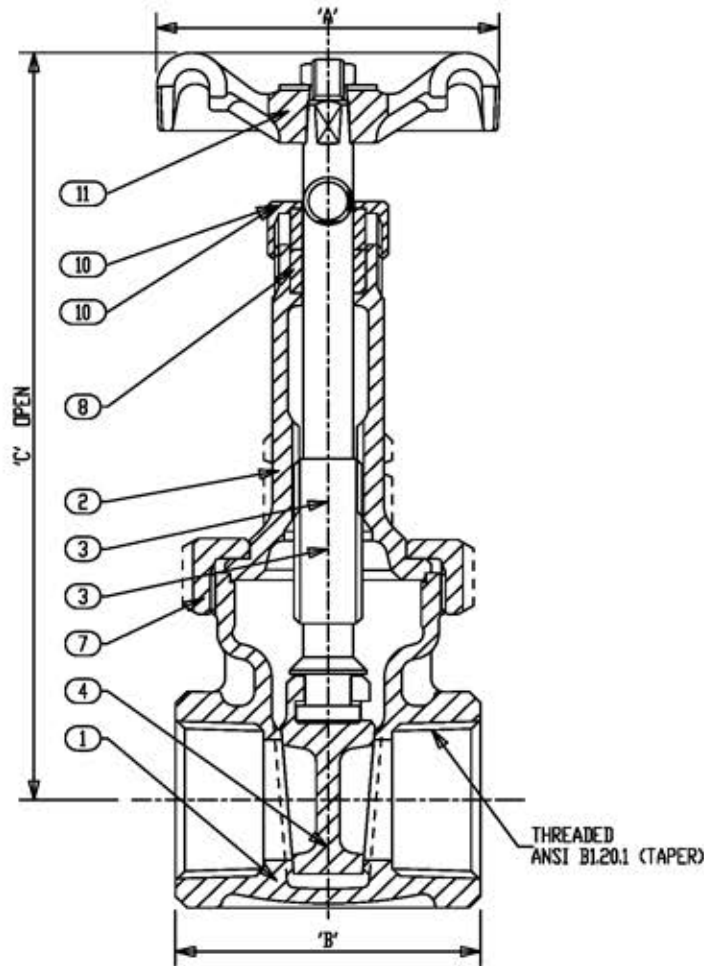

**Materials of Construction**

No.	Description	Material	ASTM Spec.
1	Body	Bronze	B-62 C83600
2	Bonnet - Union	Bronze	B-62 C83600
3	Stem	Copper Silicon Bronze	B-371 C69400
4	Disc	Bronze	B-62 C83600
5	Gland	Brass	BSEN12164 CW614N
6	Packing Nut	Bronze	B-62 C83600
7	Union Ring	Bronze	B-62 C83600
8	Packing Ring	Graphite (Asbestos Free)	WRAS Listed & Approved
10	Packing Nut	(1/4" - 2") Brass	BSEN12164 CW614N
		(2 1/2" - 3") Bronze	B-62 C83600
11	Handwheel	Malleable Iron	A-197 F22000
12	Bonnet Stud	Phosphated Steel	BS970605M36 T & BS3189
13	Bonnet Nut	Phosphated Steel	BS4190 & BS3189
14	Gasket**	(2 1/2" - 3" only) Synthetic Glass Fiber Nitrile Filled	Klingsil C4500

\*\* Not Shown  
See page 8 for Pressure-Temperature Ratings.

Industry Standards
MSS SP-80, Type 2

**Dimensions and Weights**  
Inches (millimeters) - Pounds (kilograms)

Valve Size	Dimensions			Wt.
	C	A	B	
1/4	4.96	1.75	1.81	0.7
	(126)	(45)	(46)	(0.32)
3/8	4.96	1.75	1.81	0.7
	(126)	(45)	(46)	(0.31)
1/2	5.07	2.06	1.98	1.0
	(129)	(52)	(51)	(0.46)
3/4	6.25	2.56	2.14	1.6
	(159)	(65)	(55)	(0.72)
1	7.44	2.75	2.46	2.4
	(189)	(70)	(63)	(1.10)
1 1/4	8.62	3.06	2.77	3.3
	(219)	(78)	(71)	(1.50)
1 1/2	9.68	3.62	2.85	4.9
	(246)	(92)	(73)	(2.25)
2	11.85	3.62	3.25	7.0
	(301)	(92)	(83)	(3.20)
2 1/2	14.53	5.28	4.72	12.8
	(369)	(134)	(120)	(5.80)
3	16.39	5.28	5.28	18.8
	(416)	(134)	(134)	(8.52)

\* 2 1/2" and 3" have Bolted Bonnet

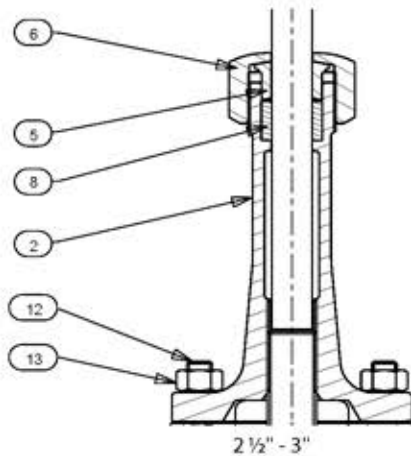



## Class 200 • Union Bonnet\* • Rising Stem • SS Seats • Thrd. Ends

### 424 Gate Valve

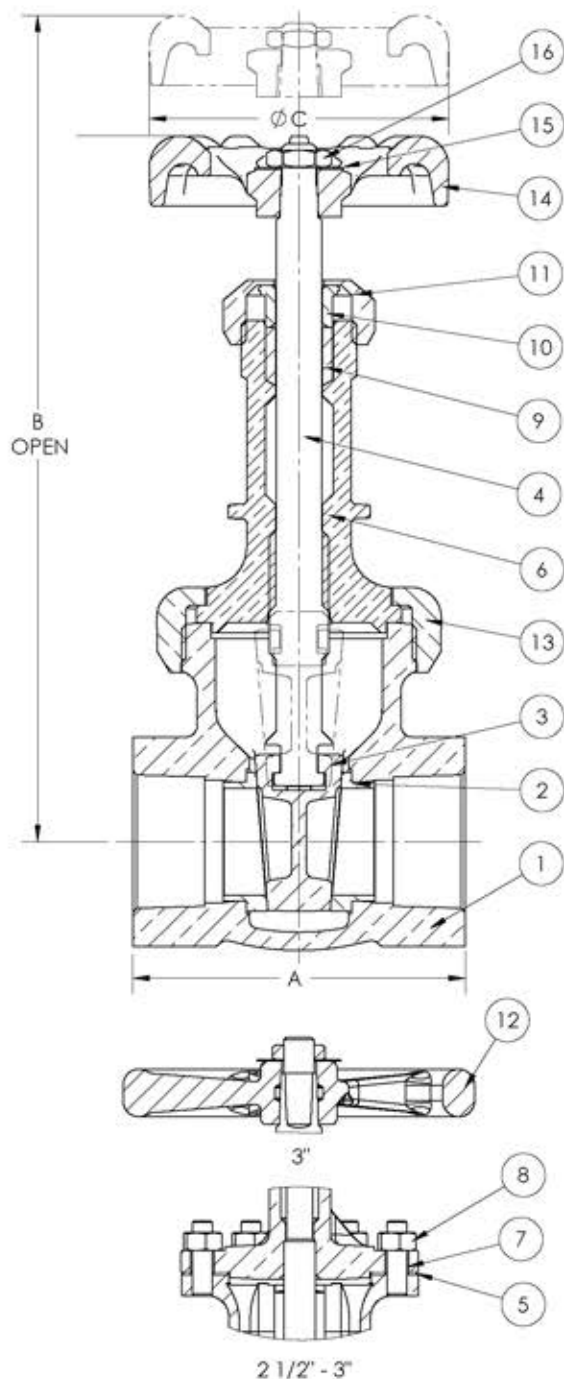

### Materials of Construction

No.	Description	Material	ASTM Spec.
1	Body	Bronze	B-61 C92200
2	Body Seat Ring	Stainless Steel	A-276 Type 410
3	Disc	Bronze	B-61 C92200
4	Stem	Bronze	B-371 C69400
5	Gasket	Synthetic/Glass Fiber with Nitrile Binder	
6	Bonnet	Bronze	B-61 C92200
7	Stud	Steel Cadmium	A-109 C1144
8	Stud Nut	Mild Steel	A-563 GR A
9	Packing	Graphite (Asbestos Free)	
10	Gland	Brass	B-16 H02
11	Packing Nut	Brass	B-16 H02
12	Handwheel 3"	Ductile Iron	-
13	Union Bonnet Ring	Bronze	B-61 C92200
14	Handwheel	(1/4" - 2 1/2") Cast Iron	
15	ID Plate	Steel Zinc Plated	
16	Lock Nut	Steel Cadmium	

See page 8 for Pressure-Temperature Ratings.

### Industry Standards

MSS SP-80, Type 2

### Dimensions and Weights

Inches (millimeters) - Pounds (kilograms)

Valve Size	Dimensions			Wt.
	B	C	A	
1/4	4.67	2.24	2.03	0.88
	(119)	(57)	(52)	(0.40)
3/8	4.67	2.24	2.13	0.90
	(119)	(57)	(54)	(0.41)
1/2	5.37	2.76	2.44	1.43
	(136)	(70)	(62)	(0.65)
3/4	6.57	2.76	2.61	2.07
	(167)	(70)	(66)	(0.94)
1	7.60	2.76	3.06	3.23
	(193)	(70)	(78)	(1.47)
1 1/4	9.09	4.02	3.35	4.86
	(231)	(102)	(85)	(2.21)
1 1/2	10.28	4.02	3.69	6.18
	(261)	(102)	(94)	(2.81)
2	12.17	4.02	3.96	10.36
	(309)	(102)	(101)	(4.71)
*2 1/2	14.37	4.76	4.60	18.61
	(365)	(121)	(117)	(8.46)
*3	16.68	5.51	5.63	31.33
	(424)	(140)	(143)	(14.24)

\* 2 1/2" and 3" have Bolted Bonnet

**Class 300 • Union Bonnet\* • Rising Stem • Threaded Ends**

**622E Gate Valve**

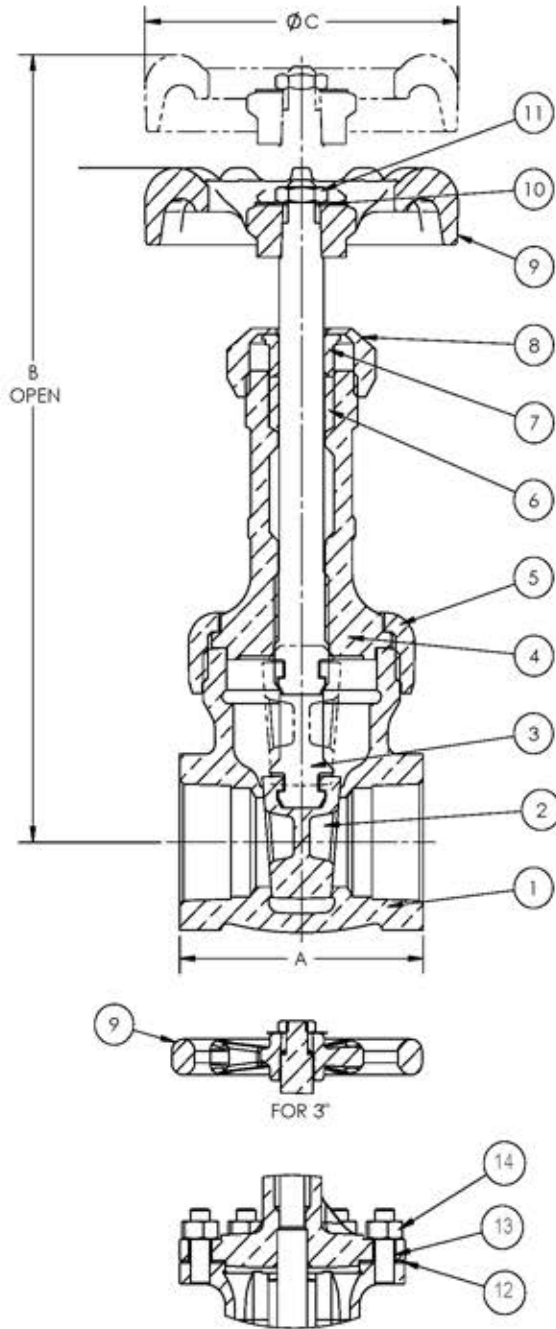

**Materials of Construction**

No.	Description	Material	ASTM Spec.
1	Body	Bronze	B-61 C92200
2	Disc	Bronze	B-61 C92200
3	Stem	Bronze	B-371 C69400
4	Bonnet	Bronze	B-61 C92200
5	Union Bonnet Ring	Bronze	B-61 C92200
6	Packing	Graphite (Asbestos Free)	
7	Gland	Brass	B-16 H02
8	Packing Nut	Brass	B-16 H02
9	Handwheel	Cast Iron (¼ - 2½") Ductile Iron (3")	
10	ID Plate	Aluminum	
11	Lock Nut	Steel Cadmium	
12	Gasket	Synthetic/Glass Fiber with Nitrile Binder	
13	Stud	Steel Cadmium	A-109 C1144
14	Stud Nut	Mild Steel	A-563 GR A

See page 8 for Pressure-Temperature Ratings.

Industry Standards
MSS SP-80, Type 2

**Dimensions and Weights**

Inches (millimeters) - Pounds (kilograms)

Valve Size	Dimensions			Wt.
	B	C	A	
¼	4.65	2.25	1.64	0.79
	(118)	(57)	(42)	(0.36)
⅜	4.65	2.25	1.64	0.77
	(118)	(57)	(42)	(0.35)
½	5.37	2.75	2.10	1.28
	(136)	(70)	(53)	(0.58)
¾	6.56	2.75	2.14	1.85
	(167)	(70)	(54)	(0.84)
1	7.60	2.75	2.47	2.99
	(193)	(70)	(63)	(1.36)
1 ¼	9.09	4.00	3.08	4.40
	(231)	(102)	(78)	(2.00)
1 ½	10.24	4.00	3.21	5.46
	(260)	(102)	(82)	(2.48)
2	12.14	4.00	3.47	9.70
	(308)	(102)	(88)	(4.41)
*2 ½	14.65	4.75	4.25	14.83
	(372)	(121)	(108)	(6.74)
*3	16.81	5.50	4.59	22.07
	(427)	(140)	(117)	(10.03)

\* 2 ½" and 3" have Bolted Bonnet

### 634E Gate Valve

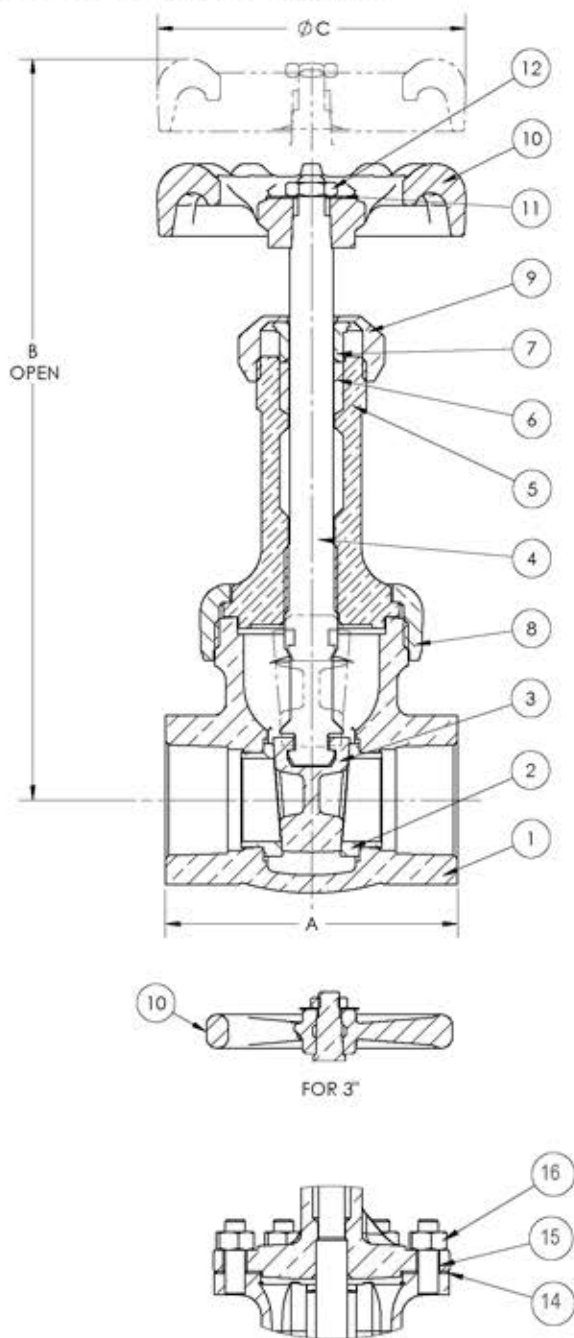

### Materials of Construction

No.	Description	Material	ASTM Spec.
1	Body	Bronze	B-61 C92200
2	Body Seat Ring	Stainless Steel	A-276 Type 410
3	Disc	Bronze	B-61 C92200
4	Stem	Bronze	B-371 C69400
5	Bonnet	Bronze	B-61 C92200
6	Packing	Graphite (Asbestos Free)	
7	Gland	Brass	B-16 H02
8	Union Bonnet Ring	Bronze	B-61 C92200
9	Packing Nut	Brass (¼ - 1½")	B-16 H02
		Bronze (2" - 3")	B-61 C92200
10	Handwheel	Cast Iron (¼ - 2½")	
		Ductile Iron (3")	
12	ID Plate	Aluminum	
13	Lock Nut	Steel Cadmium	
14	Gasket	Synthetic/Glass Fiber with Nitrile Binder	
15	Stud	Steel Cadmium	A-109 C1144
16	Stud Nut	Mild Steel	A-563 GR A

See page 8 for Pressure-Temperature Ratings.

### Industry Standards

MSS SP-80, Type 2

### Dimensions and Weights

Inches (millimeters) - Pounds (kilograms)

Valve Size	Dimensions			Wt.
	B	C	A	
¼	4.67	2.24	2.03	0.88
	(119)	(57)	(52)	(0.40)
¾	7.43	2.24	2.13	0.90
	(189)	(57)	(54)	(0.41)
½	5.37	2.76	2.44	1.43
	(136)	(70)	(62)	(0.65)
¾	6.56	2.76	2.61	2.07
	(167)	(70)	(66)	(0.94)
1	7.60	2.76	3.06	3.23
	(193)	(70)	(78)	(1.47)
1 ¼	9.09	4.02	3.35	4.86
	(231)	(102)	(85)	(2.21)
1 ½	10.28	4.02	3.69	6.18
	(261)	(102)	(94)	(2.81)
2	12.17	4.02	3.96	10.36
	(309)	(102)	(101)	(4.71)
*2 ½	14.36	4.75	4.60	19.21
	(365)	(121)	(117)	(8.73)
*3	16.71	5.51	5.63	32.82
	(425)	(140)	(143)	(14.92)

\* 2 ½" and 3" have Bolted Bonnet



**Class 300 • Union Bonnet • Non-Rising Stem • SS Seats • Thrd. Ends**

**636E Gate Valve**

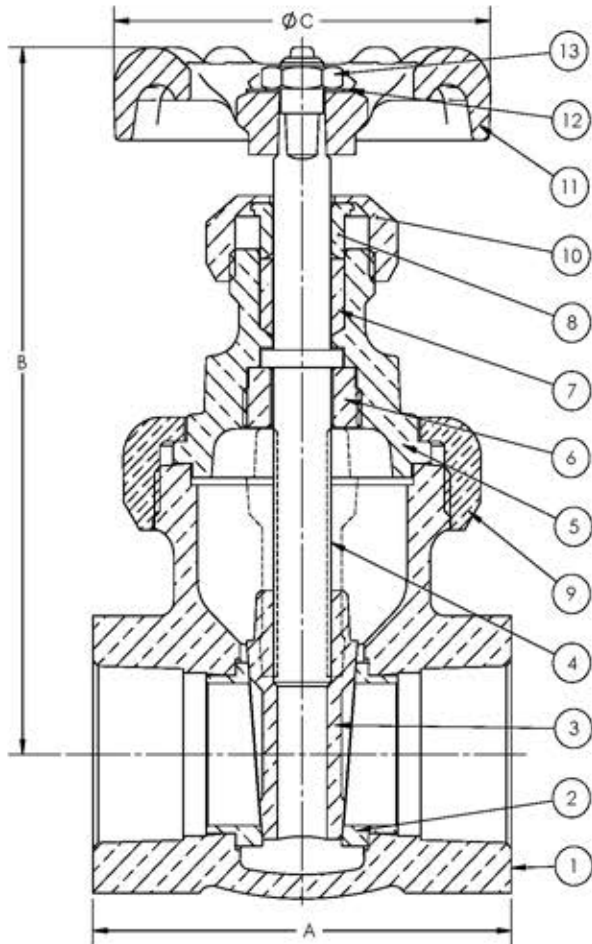

**Materials of Construction**

No.	Description	Material	ASTM Spec.
1	Body	Bronze	B-61 C92200
2	Body Seat Ring	Stainless Steel	A-276 Type 410
3	Disc	Bronze	B-61 C92200
4	Stem	Bronze	B-371 C69400
5	Bonnet	Bronze	B-61 C92200
6	Stem Retaining Nut	Brass	B-16 H02
7	Packing	Carboform	Type 11
8	Gland	Brass	B-16 H02
9	Union Bonnet Ring	Bronze	B-61 C92200
10	Packing Nut	Brass	B-16 C36000 H02
11	Handwheel	Cast Iron	
12	ID Plate	Aluminum	
13	Lock Nut	Steel Cadmium	

See page 8 for Pressure-Temperature Ratings.

Industry Standards
MSS SP-80, Type 1

**Dimensions and Weights**

Inches (millimeters) - Pounds (kilograms)

Valve Size	Dimensions			Wt.
	B	C	A	
¼	3.46	2.25	2.03	0.81
	(88)	(57)	(52)	(0.37)
⅜	3.46	2.25	2.13	0.84
	(88)	(57)	(54)	(0.38)
½	3.85	2.75	2.44	1.32
	(98)	(70)	(62)	(0.60)
¾	4.38	2.75	2.61	1.83
	(111)	(70)	(66)	(0.83)
1	4.89	2.75	3.06	2.95
	(124)	(70)	(78)	(1.34)
1 ¼	5.88	4.00	3.35	4.44
	(149)	(102)	(85)	(2.02)
1 ½	6.66	4.00	3.69	5.65
	(169)	(102)	(94)	(2.57)
2	7.51	4.00	3.96	9.61
	(191)	(102)	(101)	(4.37)

## Class 125 • Threaded Bonnet • Bronze Disc • Threaded Ends

### 1 Globe Valve

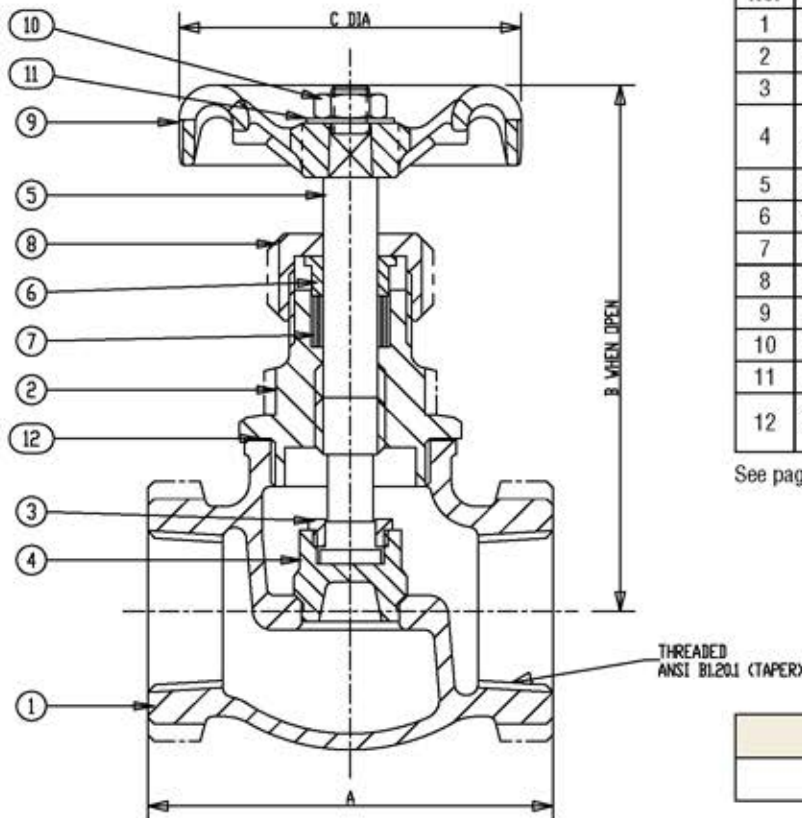

### Materials of Construction

No.	Description	Material	ASTM Spec.
1	Body	Bronze	B-62 C83600
2	Bonnet	Brass	B-62 C83600
3	Disc Stem Ring	Copper Silicon Bronze	B-371 C69400
4	Disc	( $\frac{1}{4}$ " - $\frac{3}{8}$ ") Copper Silicon Bronze	B-371 C69400
		(1" - 2") Bronze	B-62 C83600
5	Stem	Copper Silicon Bronze	B-371 C69400
6	Gland	Brass	BSEN12164 CW614N
7	Packing	Graphite (Asbestos Free)	
8	Packing Nut	Brass	BSEN12164 CW614N
9	Handwheel	Malleable Iron	A-197 F22000
10	Handwheel Nut	Brass	BSEN12164 CW614N
11	ID Plate	Aluminum	
12	Gasket	Synthetic Glass Fiber with Nitrile Filled	

See page 8 for Pressure-Temperature Ratings.

### Industry Standards

MSS SP-80, Type 1

### Dimensions and Weights

Inches (millimeters) - Pounds (kilograms)

Valve Size	Dimensions			Wt.
	B	C	A	
$\frac{1}{4}$	3.94	2.05	2.05	0.88
	(100)	(52)	(52)	(0.40)
$\frac{3}{8}$	3.94	2.05	2.05	0.86
	(100)	(52)	(52)	(0.39)
$\frac{1}{2}$	3.98	2.05	2.44	1.19
	(101)	(52)	(62)	(0.54)
$\frac{3}{4}$	4.53	2.05	2.91	1.43
	(115)	(52)	(74)	(0.65)
1	4.92	2.76	3.54	1.98
	(125)	(70)	(90)	(0.90)
1 $\frac{1}{4}$	5.91	2.76	3.94	3.48
	(150)	(70)	(100)	(1.58)
1 $\frac{1}{2}$	6.26	3.62	4.53	4.54
	(159)	(92)	(115)	(2.06)
2	7.52	4.06	5.35	7.30
	(191)	(103)	(136)	(3.31)

**Class 125 • Threaded Bonnet • PTFE Disc • Threaded Ends**

**5TF Globe Valve**

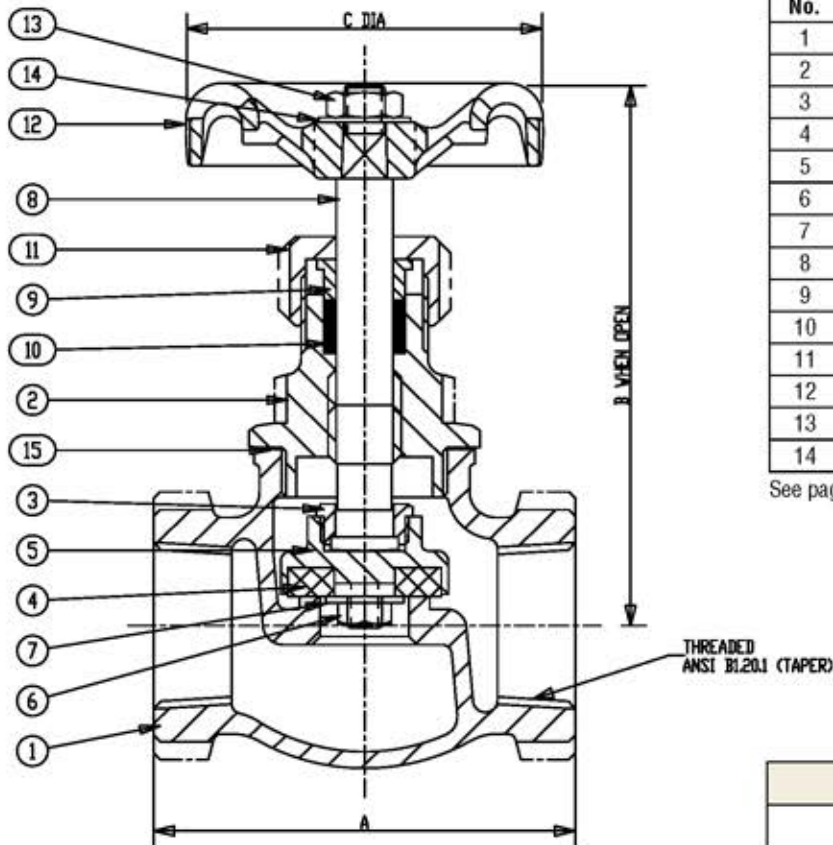

**Materials of Construction**

No.	Description	Material	ASTM Spec.
1	Body	Bronze	B-62 C83600
2	Bonnet	Bronze	B-62 C83600
3	Disc Stem Ring	Copper Silicon Bronze	B-371 C69400
4	Disc	PTFE (25% Glass Filled)	
5	Disc Holder	Bronze	B-62 C83600
6	Disc Ret Nut	Brass	BSEN12164 CW614N
7	Washer (2½ - 3")	Brass	BSEN12164 CW614N
8	Stem	Copper Silicon Steel	B-371 C69400
9	Gland	Brass	BSEN12164 CW614N
10	Packing	Graphite (Asbestos Free)	
11	Packing Nut	Brass	BSEN12164 CW614N
12	Handwheel	Malleable Iron	A-197 F22000
13	Handwheel Nut	Brass	BSEN12164 CW614N
14	ID Plate	Aluminum	

See page 8 for Pressure-Temperature Ratings.

**Industry Standards**

MSS SP-80, Type 2

**Dimensions and Weights**

Inches (millimeters) - Pounds (kilograms)

Valve Size	Dimensions			Wt.
	A	B	C	
¾	2.99	4.55	2.98	1.90
	(76)	(116)	(76)	(0.86)
½	1.94	3.66	1.96	0.70
	(49)	(93)	(50)	(0.32)
¼	2.57	3.55	2.14	1.10
	(65)	(90)	(54)	(0.48)
1	3.51	5.01	3.03	2.80
	(89)	(127)	(77)	(1.25)
1 ¼	3.88	5.10	3.70	4.10
	(99)	(130)	(94)	(1.86)
1 ½	4.67	6.05	4.63	6.20
	(119)	(154)	(118)	(2.79)
2	5.75	6.74	5.24	9.80
	(146)	(171)	(133)	(4.45)



## Class 150 • Union Bonnet • PTFE Disc • Threaded Ends

### 7TF Globe Valve

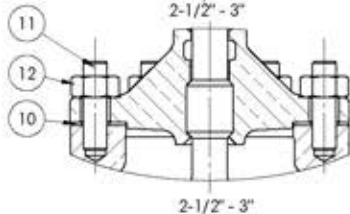
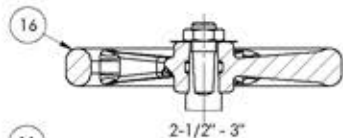
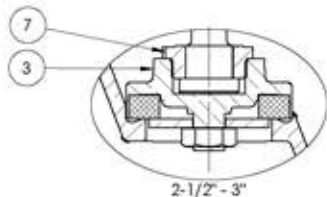
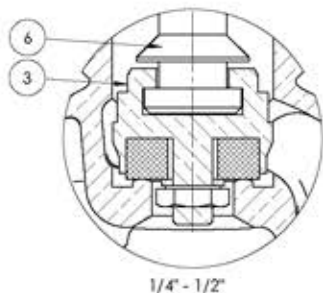
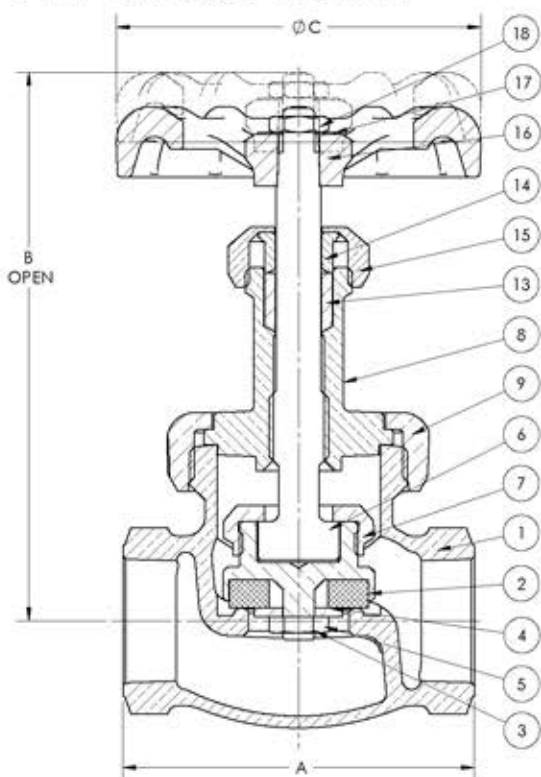

### Materials of Construction

No.	Description	Material	ASTM Spec.
1	Body	Bronze	B-62 C83600
2	Disc	PTFE (15% Glass Filled)	
3	Disc Holder	(1/4" - 1/2") Brass (3/4" - 3") Bronze	B-16 H02 B-62 C83600
4	Disc Washer	Brass	B-16 H02
5	Lock Nut	Brass	B-16 H02
6	Stem	(1/4" - 3/8") Bronze (1/2" - 3") Bronze	B-371 C69400 B-371 C69400
7	Disc Stem Ring	(1/2" - 3/4") Brass (2 1/2" - 3") Bronze	B-16 H02 B-61 C92200
8	Bonnet	(1/4" - 3/4") Brass (1/2" - 3") Bronze	B-16 H02 B-62 C83600
9	Union Bonnet Ring	(1/4" - 2") Bronze	B-62 C83600
10	Gasket	Synthetic Glass Fiber with Nitrile Binder	
11	Stud	Steel Cadmium	A-109 C1145
12	Nut	Mild Steel	A-563 GR. A
13	Packing	Graphite (Asbestos Free)	
14	Gland	Brass	B-16 H02
15	Packing Nut	Brass (1/4" - 1 1/2") Bronze (2" - 3")	B-16 H02 B-61 C92200
16	Handwheel	Cast Iron (1/4" - 2") Ductile Iron (2 1/2" - 3")	
17	ID Plate	Aluminum	
18	Lock Nut	Steel Cadmium	

See page 8 for Pressure-Temperature Ratings.

### Industry Standards

MSS SP-80, Type 2

### Dimensions and Weights

Inches (millimeters) - Pounds (kilograms)

Valve Size	Dimensions			Wt.
	B	C	A	
1/4	4.19 (107)	2.76 (70)	1.94 (49)	0.97 (0.44)
	4.20 (107)	2.76 (70)	1.94 (49)	0.99 (0.45)
1/2	4.06 (103)	2.76 (70)	2.56 (65)	1.25 (0.57)
	5.00 (127)	2.76 (70)	2.96 (75)	1.91 (0.87)
1	5.59 (142)	4.02 (102)	3.50 (89)	3.21 (1.46)
	6.51 (165)	4.02 (102)	4.02 (102)	4.47 (2.03)
1 1/2	6.91 (176)	4.02 (102)	4.58 (116)	6.25 (2.84)
	7.40 (188)	4.76 (121)	5.70 (145)	11.07 (5.03)
*2 1/2	8.69 (221)	5.51 (140)	7.25 (184)	19.65 (8.93)
	10.25 (260)	5.98 (152)	8.50 (216)	33.22 (15.10)

\*2 1/2" and 3" have Bolted Bonnet

**300 CWP • Threaded Bonnet • PTFE Disc • Solder Ends**

**1310 Globe Valve**

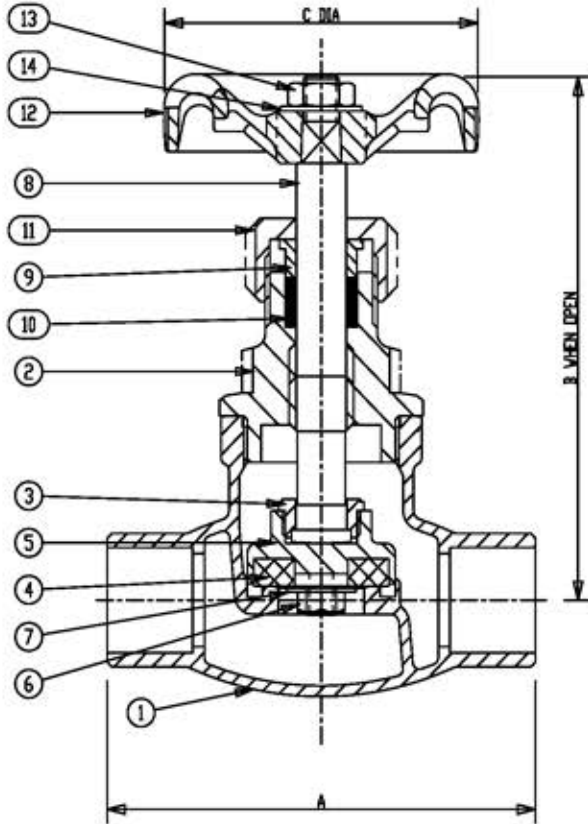

**Materials of Construction**

No.	Description	Material	ASTM Spec.
1	Body	Bronze	B-62 C83600
2	Bonnet	Bronze	B-62 C83600
3	Disc Stem Ring	Copper Silicon Bronze	B-371 C69400
4	Disc	PTFE (25% Glass Filled)	
5	Disc Holder	Bronze	B-62 C83600
6	Disc Ret Nut	Brass	BSEN12164 CW614N
7	Washer	Brass	BSEN12164 CW614N
8	Stem	Copper Silicon Steel	B-371 C69400
9	Gland	Brass	BSEN12164 CW614N
10	Packing	Graphite (Asbestos Free)	
11	Packing Nut	Brass	BSEN12164 CW614N
12	Handwheel	Malleable Iron	A-197 F22000
13	Handwheel Nut	Brass	BSEN12164 CW614N
14	ID Plate	Aluminum	

**Caution:** Before installing solder-joint valves, be sure solder or brazing alloy melting point is high enough to withstand line pressure, temperature conditions, and is compatible with fluid medium.

See page 7 for Adjusted Pressure-Temperature Ratings.

Industry Standards
MSS SP-80, Type 2

**Dimensions and Weights**

Inches (millimeters) - Pounds (kilograms)

Valve Size	Dimensions			Wt.
	B	C	A	
3/8	3.94	2.05	2.32	1.90
	(100)	(52)	(59)	(0.39)
1/2	3.98	2.05	2.91	2.62
	(101)	(52)	(74)	(0.54)
3/4	4.53	2.05	3.74	3.15
	(115)	(52)	(95)	(0.65)
1	4.92	2.76	4.57	3.95
	(125)	(70)	(116)	(0.81)
1 1/4	5.91	2.76	4.92	7.54
	(150)	(70)	(125)	(1.55)
1 1/2	6.26	3.62	5.75	9.31
	(159)	(92)	(146)	(2.01)
2	7.52	4.06	7.09	14.97
	(191)	(103)	(180)	(3.08)

### 14 1/2 P Globe Valve

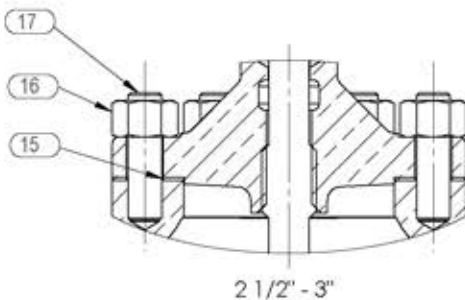
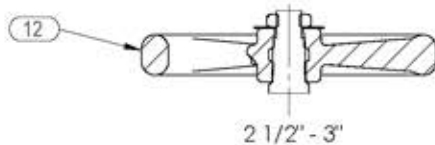
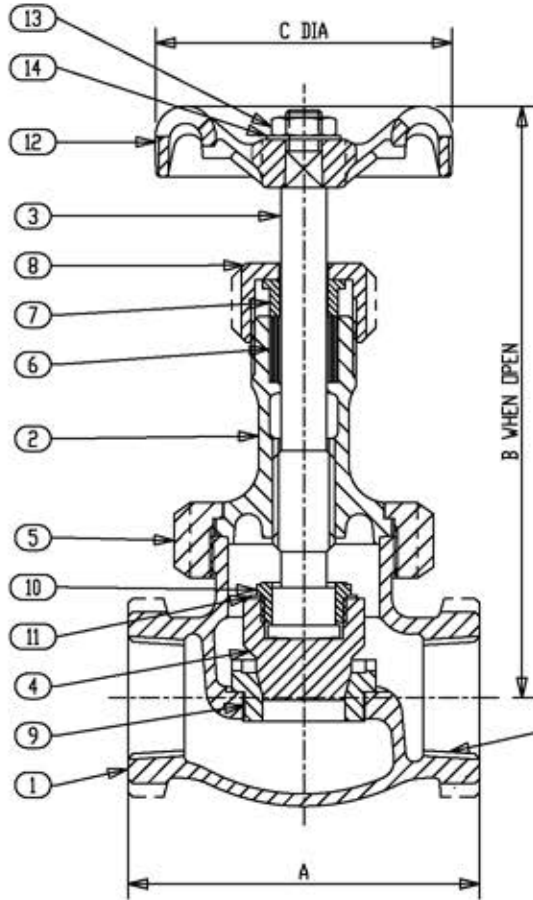

### Materials of Construction

No.	Description	Material	ASTM Spec.
1	Body	Bronze	B-61 C92200
2	Bonnet	Bronze	B-61 C92200
3	Stem	Copper Silicon Bronze	B-371 C69400
4	Disc	316 Stainless Steel	
5	Union Ring	Bronze	B-62 C83600
6	Packing	Graphite (Asbestos Free)	
7	Gland	Brass	BSEN12164 CW614N
8	Packing Nut	(1/4\" - 1 1/2\") Brass	BSEN12164 CW614N
		(2\" - 3\") Bronze	B-62 C83600
9	Body Seat Ring	13% CR Steel	BS970 Pt1 410S21 or BS970 Pt1 431S29
10	Disc Stem Ring	Mang. Bronze	B-371 C69400
11	Lock Washer	Brass	BS2870 - CZ 123
12	Handwheel	Malleable Iron	A-197 F22000
13	Handwheel Nut	Brass	BSEN12164 CW614N
14	ID Plate	Aluminum	
15	Gasket	Synthetic/Glass Fiber with Nitrile Binder	
16	Stud	Steel Cadmium	A-109 C1145
17	Nut	Mild Steel	A-563 Gr-A

See page 8 for Pressure-Temperature Ratings.

### Industry Standards

MSS SP-80, Type 3

### Dimensions and Weights

Inches (millimeters) - Pounds (kilograms)

Valve Size	Dimensions			Wt.
	B	C	A	
1/4	1.97	4.43	2.13	0.90
	(50)	(113)	(54)	(0.39)
3/8	1.97	4.43	2.13	0.90
	(50)	(113)	(54)	(0.39)
1/2	2.63	4.09	2.25	1.30
	(67)	(104)	(57)	(0.59)
3/4	2.99	5.10	2.98	2.20
	(76)	(130)	(76)	(1.00)
1	3.51	5.58	3.02	3.20
	(89)	(142)	(77)	(1.45)
1 1/4	4.04	6.42	3.68	4.80
	(103)	(163)	(93)	(2.18)
1 1/2	4.57	7.17	4.63	7.10
	(116)	(182)	(118)	(3.22)
2	5.72	7.48	5.24	11.50
	(145)	(190)	(133)	(5.20)
*2 1/2	7.28	8.44	6.97	25.10
	(185)	(214)	(177)	(11.37)
*3	8.70	9.79	7.00	40.50
	(221)	(249)	(178)	(18.38)



**Class 200 • Union Bonnet\* • SS Plug Type Disc • Thrd. Ends**

**212P Globe Valve**

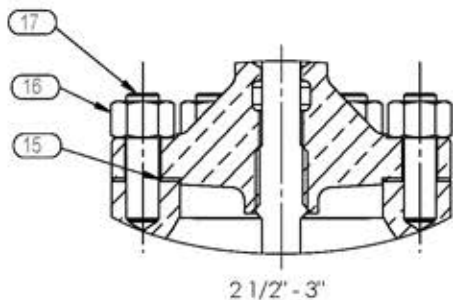
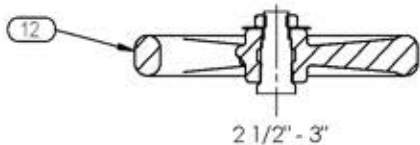
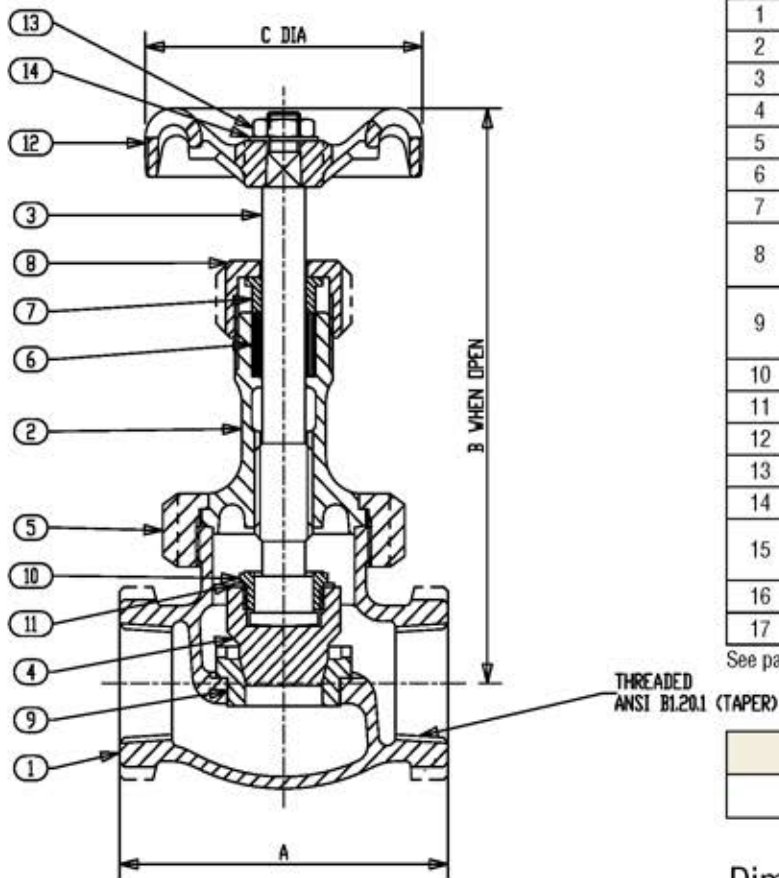

**Materials of Construction**

No.	Description	Material	ASTM Spec.
1	Body	Bronze	B-61 C92200
2	Bonnet	Bronze	B-61 C92200
3	Stem	Copper Silicon Bronze	B-371 C69400
4	Disc	316 Stainless Steel	
5	Union Ring	Bronze	B-62 C83600
6	Packing	Graphite (Asbestos Free)	
7	Gland	Brass	BSEN12164 CW614N
8	Packing Nut	(1/4" - 1 1/2") Brass	BSEN12164 CW614N
		(2" - 3") Bronze	B-62 C83600
9	Body Seat Ring	13% CR Steel	BS970 Pt1 410S21 or BS970 Pt1 431S29
10	Disc Stem Ring	Mang. Bronze	B-371 C69400
11	Lock Washer	Brass	BS2870 - CZ 123
12	Handwheel	Malleable Iron	A-197 F22000
13	Handwheel Nut	Brass	BSEN12164 CW614N
14	ID Plate	Aluminum	
15	Gasket	Synthetic/Glass Fiber with Nitrile Binder	
16	Stud	Steel Cadmium	A-109 C1145
17	Nut	Mild Steel	A-563 Gr-A

See page 8 for Pressure-Temperature Ratings.

**Industry Standards**

MSS SP-80, Type 3

**Dimensions and Weights**

Inches (millimeters) - Pounds (kilograms)

Valve Size	Dimensions			Wt.
	B	C	A	
1/4	4.80	2.05	2.32	1.24
	(122)	(52)	(59)	(0.56)
3/8	4.80	2.05	2.32	1.24
	(122)	(52)	(59)	(0.56)
1/2	5.51	2.56	2.68	1.76
	(140)	(65)	(68)	(0.80)
3/4	5.98	2.76	3.19	2.73
	(152)	(70)	(81)	(1.24)
1	6.73	3.07	3.74	4.01
	(171)	(78)	(95)	(1.82)
1 1/4	7.60	3.62	4.25	6.02
	(193)	(92)	(108)	(2.73)
1 1/2	8.66	4.06	4.76	8.34
	(220)	(103)	(121)	(3.78)
2	9.88	4.76	5.75	13.30
	(251)	(121)	(146)	(6.03)
*2 1/2	10.98	5.98	7.24	24.04
	(279)	(152)	(184)	(10.9)
*3	12.32	7.00	8.27	36.16
	(313)	(178)	(210)	(16.4)

\*2 1/2" and 3" have Bolted Bonnet

## Class 200 • Threaded Bonnet • Needle Type Disc • Thrd. Ends

### 88 Globe Valve

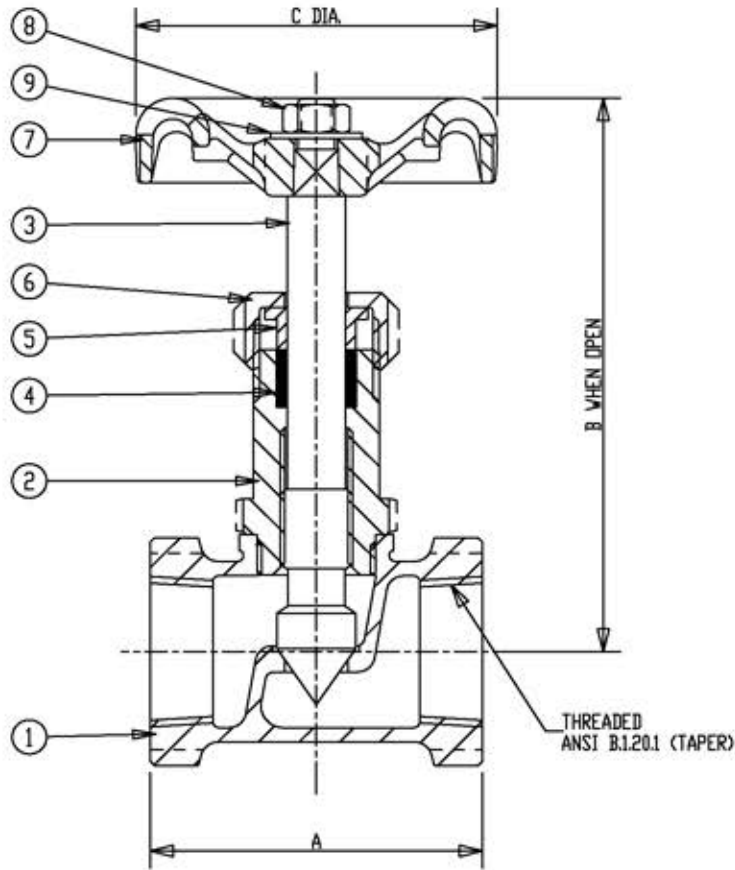

### Materials of Construction

No.	Description	Material	ASTM Spec.
1	Body	Bronze	B-62 C83600
2	Bonnet	(1/8" - 1/2") Sil. Al. Bronze	BSEN12163 CW301G
		(3/4") Brass	BSEN12164 CW614N
3	Stem	Sil. Al. Bronze	BSEN12163 CW301G
4	Packing	Graphite (Asbestos Free)	
5	Gland	Brass	BSEN12164 CW614N
6	Packing Nut	Brass	BSEN12164 CW614N
7	Handwheel	Aluminum	
8	Handwheel Nut	Brass	BSEN12164 CW614N
9	ID Plate	Aluminum	

See page 8 for Pressure-Temperature Ratings.

### Industry Standards

MSS SP-80, Type 1

### Dimensions and Weights

Inches (millimeters) - Pounds (kilograms)

Valve Size	Dimensions			Wt.
	B	C	A	
1/8	2.91	1.73	1.14	0.29
	(74)	(44)	(29)	(0.13)
1/4	2.87	1.73	1.54	0.33
	(73)	(44)	(39)	(0.15)
3/8	3.03	1.73	1.77	0.46
	(77)	(44)	(45)	(0.21)
1/2	3.58	2.05	2.01	0.64
	(91)	(52)	(51)	(0.29)
3/4	4.09	2.56	2.28	1.01
	(104)	(65)	(58)	(0.46)

**Class 300 • Union Bonnet\* • Plug-Type Disc • Renewable SS Seats**

**382P Globe Valve**

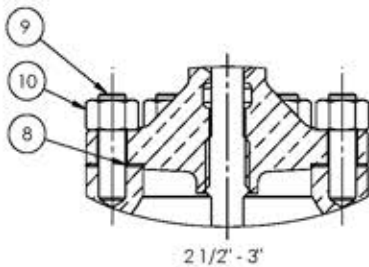
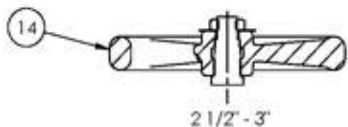
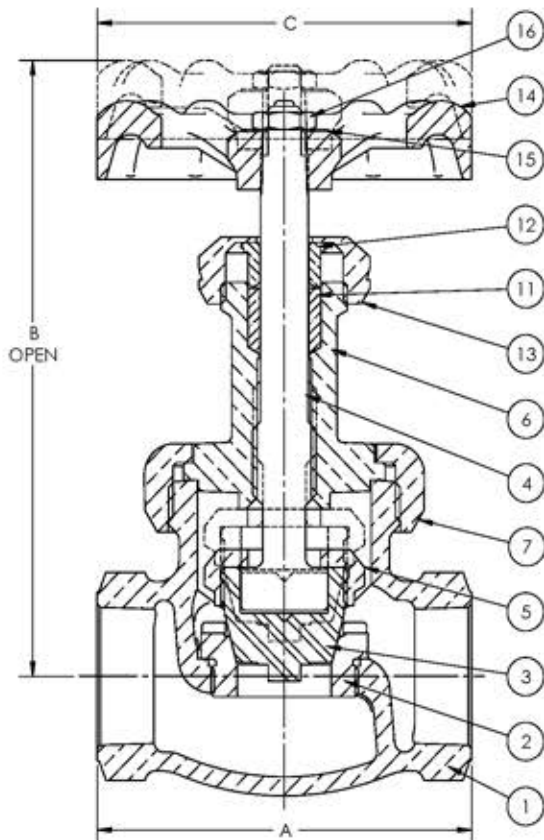

**Materials of Construction**

No.	Description	Material	ASTM Spec.
1	Body	Bronze	B-61 C92200
2	Body Seat Ring	Stainless Steel	AISI 420 SS
3	Disc	Stainless Steel	AISI 420F SS
4	Stem	Bronze	B-371 C69400
5	Disc Stem Ring	(1/4\" - 3/4\") Brass (1\" - 3\") Bronze	B-16 H02 B-61 C92200
6	Bonnet	(1/4\" - 3/8\") Brass (1/2\" - 3\") Bronze	B-16 H02 B-61 C92200
7	Union Bonnet Ring	Bronze	B-61 C92200
8	Gasket	Synthetic/Glass Fiber with Nitrile Binder	
9	Stud	Steel Cadmium	A-109 C1145
10	Nut	Mild Steel	A-563 Gr-A
11	Packing	Graphite (Asbestos Free)	Type 11
12	Gland	Brass	B-16 H02
13	Packing Nut	Brass (1/4 1 1/2\") Bronze (2-3\")	B-16 H02 B-61 C92200
14	Handwheel	Cast Iron Ductile Iron	
15	ID Tag	Aluminum	
16	Lock Nut	Steel Cadmium	

See page 8 for Pressure-Temperature Ratings.

Industry Standards
MSS SP-80, Type 3

**Dimensions and Weights**

Inches (millimeters) - Pounds (kilograms)

Valve Size	Dimensions			Wt.
	B	C	A	
1/4	4.47	2.76	1.94	0.97
	(114)	(70)	(49)	(0.44)
3/8	4.47	2.76	1.94	0.95
	(114)	(70)	(49)	(0.43)
1/2	4.06	2.76	2.56	1.36
	(103)	(70)	(65)	(0.62)
3/4	4.98	2.76	2.96	2.20
	(127)	(70)	(75)	(1.00)
1	5.59	4.02	3.50	3.50
	(142)	(102)	(89)	(1.59)
1 1/4	6.48	4.02	4.02	4.93
	(165)	(102)	(102)	(2.24)
1 1/2	6.85	4.02	4.58	6.86
	(174)	(102)	(116)	(3.12)
2	7.39	4.76	5.70	12.83
	(188)	(121)	(145)	(5.83)
*2 1/2	9.68	5.51	7.24	23.58
	(246)	(140)	(184)	(10.7)
*3	11.02	5.98	8.50	34.83
	(280)	(152)	(216)	(15.8)

\* 2 1/2\" and 3\" have Bolted Bonnet



### 17TF Angle Valve

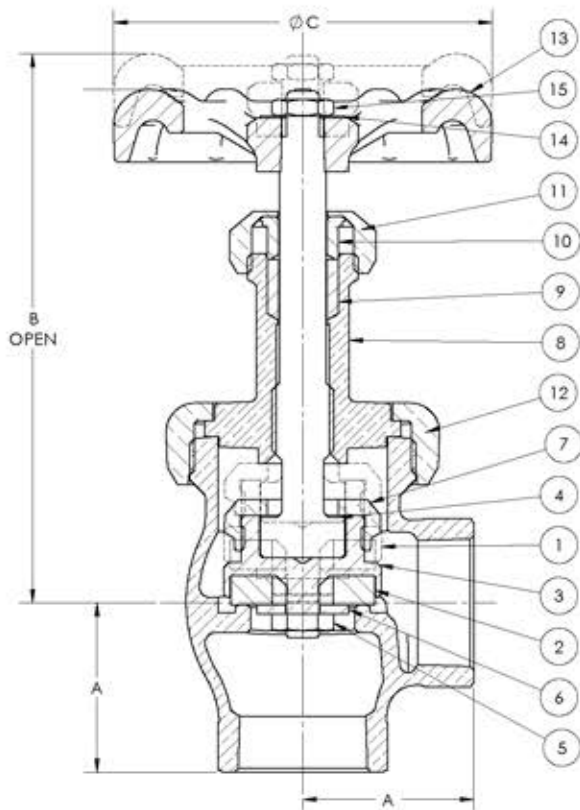

### Materials of Construction

No.	Description	Material	ASTM Spec.
1	Body	Bronze	B-62 C83600
2	Disc	PTFE (15% Glass Filled)	
3	Disc Holder	(1/4" - 1/2") Brass	B-16 H02
		(3/4" - 2") Bronze	B-62 C83600
4	Stem	Bronze	B-371 C69400
5	Lock Nut	Brass	B-16 H02
6	Disc Washer	Brass	B-16 H02
7	Disc Stem Ring	Bronze	B-61 C92200
8	Bonnet	(1/4" - 3/8") Brass	B-16 H02
		(1/2" - 2") Bronze	B-62 C83600
9	Packing	Graphite (Asbestos Free)	
10	Gland	Brass	B-16 H02
11	Packing Nut	(1/4" - 1 1/2") Brass	B-16 C36000 H02
		(2") Bronze	B-61 C92200
12	Union Bonnet Ring	Bronze	B-62 C83600
13	Handwheel	Cast Iron	
14	ID Plate	Aluminum	
15	Lock Nut	Steel Cadmium	

See page 8 for Pressure-Temperature Ratings.

### Industry Standards

MSS SP-80, Type 2

### Dimensions and Weights

Inches (millimeters) - Pounds (kilograms)

Valve Size	Dimensions			Wt.
	B	C	A	
1/4	4.05	2.76	1.13	1.03
	(103)	(70)	(29)	(0.47)
3/8	4.05	2.76	1.13	1.01
	(103)	(70)	(29)	(0.46)
1/2	3.92	2.76	1.15	1.21
	(100)	(70)	(29)	(0.55)
3/4	4.78	2.76	1.39	1.80
	(122)	(70)	(35)	(0.82)
1	5.42	4.02	1.64	3.01
	(138)	(102)	(42)	(1.37)
1 1/4	6.38	4.02	2.00	4.51
	(162)	(102)	(51)	(2.05)
1 1/2	6.69	4.02	2.18	6.01
	(170)	(102)	(55)	(2.73)
2	7.14	4.76	2.65	10.69
	(181)	(121)	(67)	(4.86)

**Class 200 • Threaded Bonnet • Needle Type Disc • Thrd. Ends**

**89 Angle Valve**

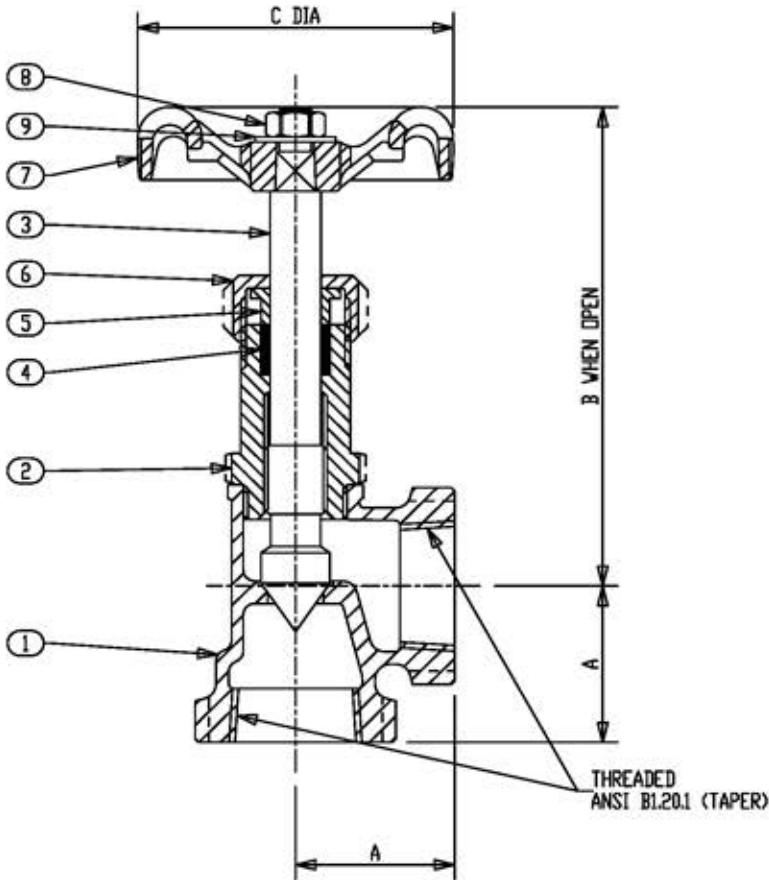

**Materials of Construction**

No.	Description	Material	ASTM Spec.
1	Body	Bronze	B-62 C83600
2	Bonnet	( $\frac{1}{8}$ " - $\frac{3}{8}$ ") Sil. Al. Bronze	BSEN12163 CW301G
		( $\frac{1}{2}$ " - $\frac{3}{4}$ ") Brass	BSEN12164 CW614N
3	Stem	Sil. Al. Bronze	BSEN12163 CW301G
4	Packing	Graphite (Asbestos Free)	
5	Gland	Brass	BSEN12164 CW614N
6	Packing Nut	Brass	BSEN12164 CW614N
7	Handwheel	Aluminum	
8	Handwheel Nut	Brass	BSEN12164 CW614N
9	ID Plate		Aluminum

See page 8 for Pressure-Temperature Ratings.

**Industry Standards**

MSS SP-80, Type 1

**Dimensions and Weights**

Inches (millimeters) - Pounds (kilograms)

Valve Size	Dimensions			Wt.
	B	C	A	
$\frac{1}{8}$	2.91	1.73	0.59	0.29
	(74)	(44)	(15)	(0.13)
$\frac{1}{4}$	2.87	1.73	0.79	0.33
	(73)	(44)	(20)	(0.15)
$\frac{3}{8}$	3.03	1.73	0.91	0.46
	(77)	(44)	(23)	(0.21)
$\frac{1}{2}$	3.58	2.05	1.06	0.64
	(91)	(52)	(27)	(0.29)
$\frac{3}{4}$	4.09	2.56	1.26	1.01
	(104)	(65)	(32)	(0.46)

## Class 300 • Union Bonnet • Plug-Type Disc • Renewable SS Seats

### 384P Angle Valve

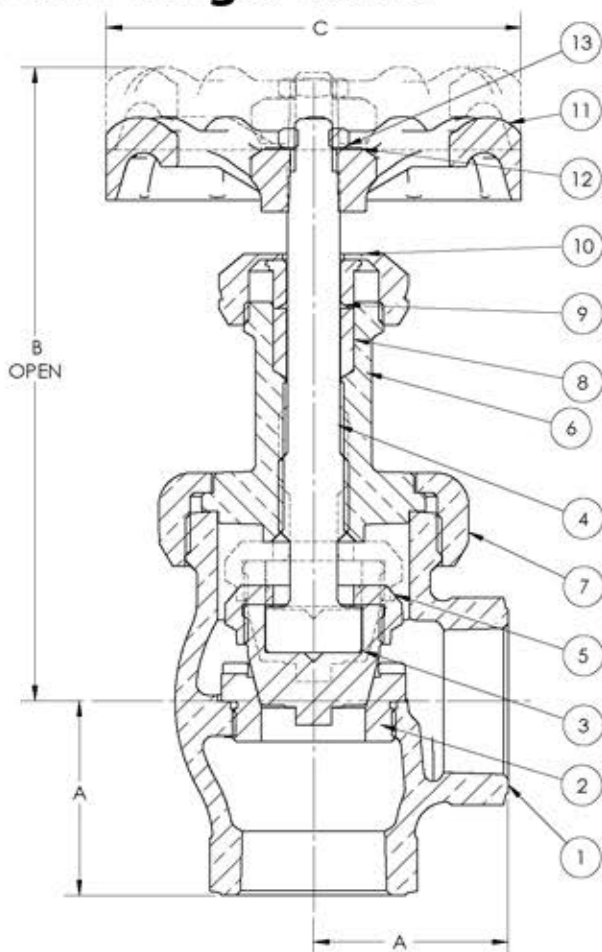

### Materials of Construction

No.	Description	Material	ASTM Spec.
1	Body	Bronze	B-61 C92200
2	Body Seat Ring	Stainless Steel	AISI 420 SS
3	Disc	Stainless Steel	AISI 420F SS
4	Stem	Bronze	B-371 C69400
5	Disc Stem Ring	( $\frac{1}{2}$ " - $\frac{3}{4}$ ") Brass	B-16 H02
		(1" - 2") Bronze	B-61 C92200
6	Bonnet	Bronze	B-61 C92200
7	Union Bonnet Ring	Bronze	B-61 C92200
8	Packing	Graphite (Asbestos Free)	
9	Gland	Brass	B-16 H02
10	Packing Nut	( $\frac{1}{2}$ " - 1 $\frac{1}{2}$ ") Brass	B-16 H02
		(2") Bronze	B-61 C92200
11	Handwheel	Ductile Iron	
12	ID Plate	Aluminum	
13	Lock Nut	Steel Cadmium	

See page 8 for Pressure-Temperature Ratings.

### Industry Standards

MSS SP-80, Type 3

### Dimensions and Weights

Inches (millimeters) - Pounds (kilograms)

Valve Size	Dimensions			Wt.
	B	C	A	
$\frac{1}{2}$	3.97	2.76	1.15	1.32
	(101)	(70)	(29)	(0.60)
$\frac{3}{4}$	4.83	2.76	1.39	2.16
	(123)	(70)	(35)	(0.98)
1	5.41	4.02	1.64	3.45
	(138)	(102)	(42)	(1.57)
1 $\frac{1}{4}$	6.38	4.02	2.00	5.21
	(162)	(102)	(51)	(2.37)
1 $\frac{1}{2}$	6.74	4.02	2.18	6.62
	(171)	(102)	(55)	(3.01)
2	7.13	4.76	2.69	12.32
	(181)	(121)	(68)	(5.60)



**Class 125 • Threaded Cap • Brass/Bonze Disc • Threaded Ends**

**37 Swing Check Valve**

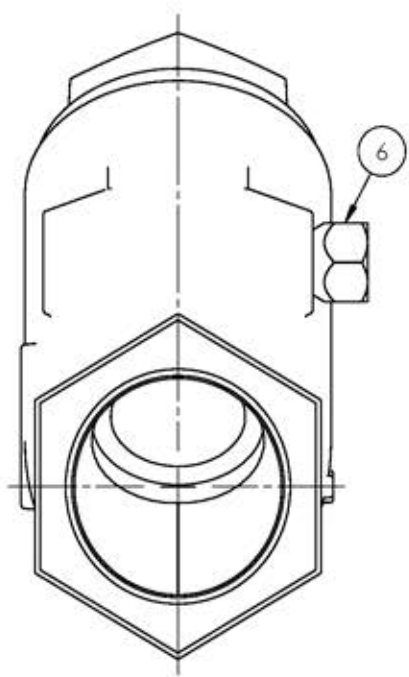
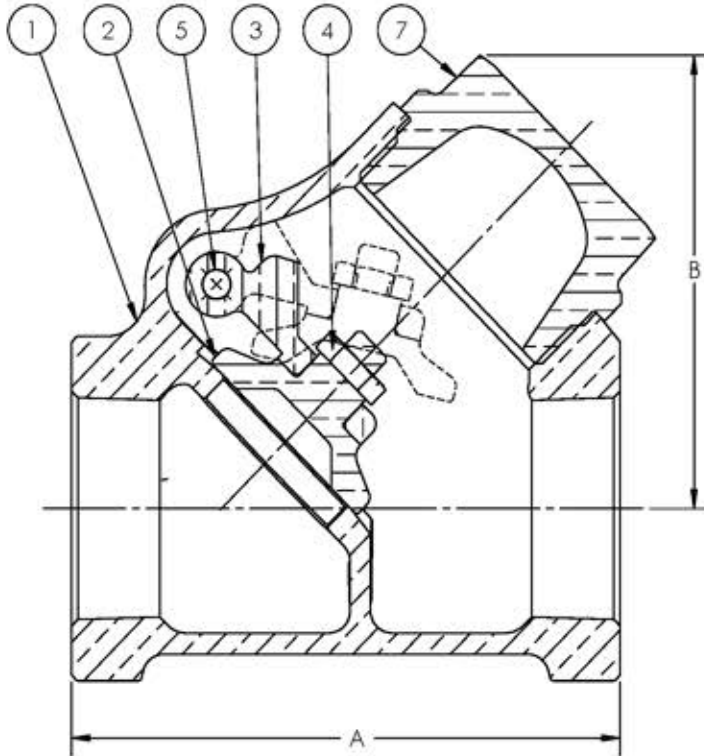

**Materials of Construction**

No.	Description	Material	ASTM Spec.
1	Body	Bronze	B-62 C83600
2	Disc	(1/4" - 3/4") Brass	B-16 H02
		(1" - 2") Bronze	B-61 C92200
		(2 1/2" - 3") Bronze	B-62 C83600
3	Hinge	Bronze	B-584 C87600
4	Lock Nut	Brass	B-16 H02
5	Hinge Pin	Stainless Steel	A-276 Type 304
6	Hinge Pin Plug	Brass	B-16 H02
7	Cap	Bronze	B-61 C92200

**Caution:** Not recommended for use with reciprocating pumps or air compressors in liquid or gas services. See page 8 for Pressure-Temperature Ratings.

Industry Standards
MSS SP-80, Type 3

**Dimensions and Weights**  
Inches (millimeters) - Pounds (kilograms)

Valve Size	Dimensions		Wt.
	B	A	
1/4	1.49	2.14	0.48
	(38)	(54)	(0.22)
3/8	1.49	2.14	0.46
	(38)	(54)	(0.21)
1/2	1.64	2.15	0.57
	(42)	(55)	(0.26)
3/4	1.92	2.71	0.90
	(49)	(69)	(0.41)
1	2.52	3.18	1.43
	(64)	(81)	(0.65)
1 1/4	2.95	3.81	2.27
	(75)	(97)	(1.03)
1 1/2	3.43	4.34	3.61
	(87)	(110)	(1.64)
2	4.19	5.11	5.70
	(106)	(130)	(2.59)
2 1/2	5.04	6.12	9.09
	(128)	(155)	(4.13)
3	5.97	7.25	14.59
	(152)	(184)	(6.63)

## Class 125 • Threaded Cap • PTFE Disc • Threaded Ends

### 41TF Swing Check Valve

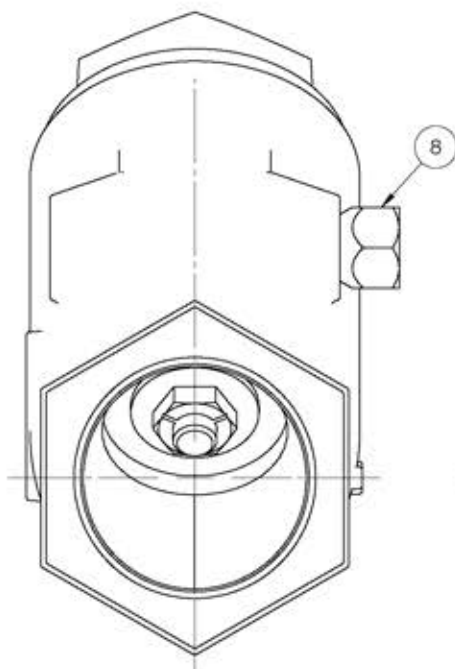
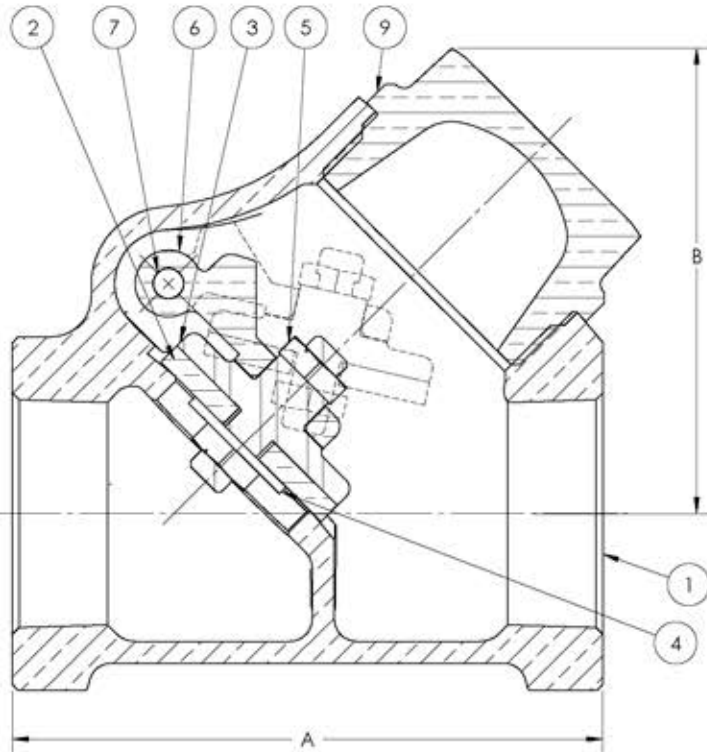

### Materials of Construction

No.	Description	Material	ASTM Spec.
1	Body	Bronze	B-62 C83600
2	Disc	PTFE (15% Glass filled)	
3	Disc Holder	(1/2" - 3/4") Brass	B-16 H02
		(1" - 2") Bronze	B-62 C83600
4	Disc Washer	Brass	B-16 H02
5	Lock Nut	Brass	B-16 H02
6	Hinge	Bronze	B-584 C87600
7	Hinge Pin	Stainless Steel	A-276 Type 304
8	Hinge Pin Plug	Brass	B-16 H02
9	Cap	Bronze	B-61 C92200

**Caution:** Not recommended for use with reciprocating pumps or air compressors in liquid or gas services.

See page 8 for Pressure-Temperature Ratings.

### Industry Standards

MSS SP-80, Type 4

### Dimensions and Weights

Inches (millimeters) - Pounds (kilograms)

Valve Size	Dimensions		Wt.
	B	A	
1/2	1.64	2.15	0.55
	(42)	(55)	(0.25)
3/4	1.92	2.71	0.90
	(49)	(69)	(0.41)
1	2.52	3.18	1.45
	(64)	(81)	(0.66)
1 1/4	2.95	3.81	2.29
	(75)	(97)	(1.04)
1 1/2	3.43	4.34	3.65
	(87)	(110)	(1.66)
2	4.19	5.11	5.79
	(106)	(130)	(2.63)

**Class 150 • Threaded Cap • Brass/Bronze Disc • Threaded Ends**

**137 Swing Check Valve**

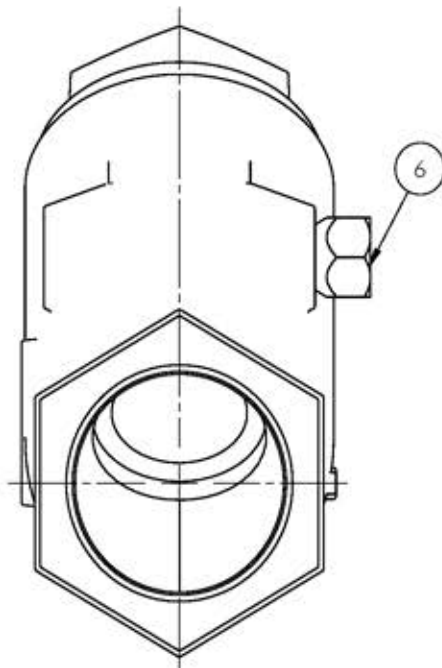
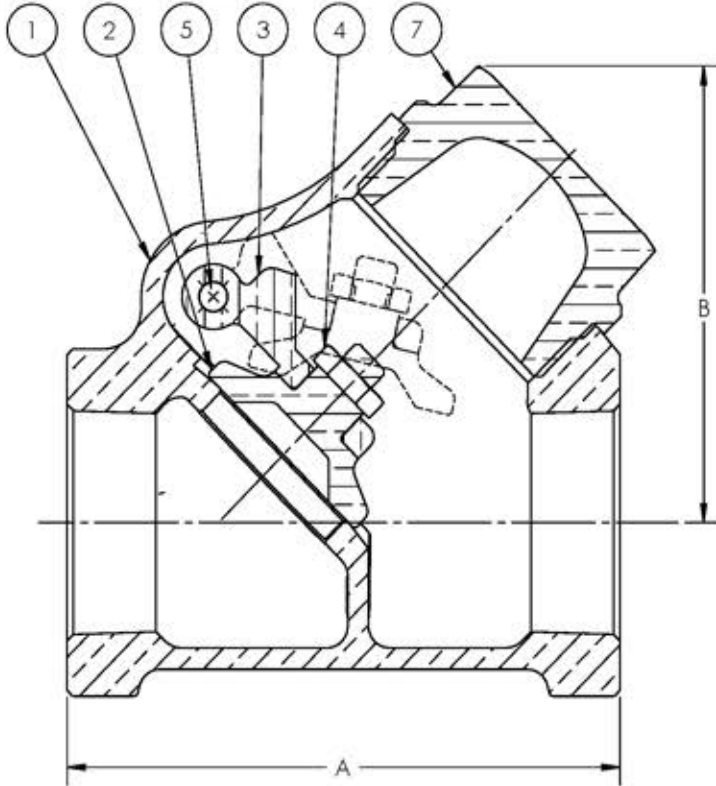

**Materials of Construction**

No.	Description	Material	ASTM Spec.
1	Body	(1/4" - 1/2") Bronze	B-62 C83600
		(1/2" - 3") Bronze	B-62 C83600
2	Disc	(1/4" - 1/2") Brass	B-16 H02
		(1" - 2") Bronze	B-61 C92200
		(2 1/2" - 3") Bronze	B-62 C83600
3	Hinge	Bronze	B-584 C87600
4	Lock Nut	Brass	B-16 H02
5	Hinge Pin	Stainless Steel	A-276 Type 304
6	Hinge Pin Plug	Brass	B-16 H02
7	Cap	Bronze	B-61 C92200

**Caution:** Not recommended for use with reciprocating pumps or air compressors in liquid or gas services. See page 8 for Pressure-Temperature Ratings.

Industry Standards
MSS SP-80, Type 3

**Dimensions and Weights**

Inches (millimeters) - Pounds (kilograms)

Valve Size	Dimensions		Wt.
	B	A	
1/4	1.49 (38)	2.14 (54)	0.50 (0.23)
	1.49 (38)	2.14 (54)	0.50 (0.23)
1/2	1.64 (42)	2.15 (55)	0.60 (0.27)
	1.92 (49)	2.71 (69)	1.00 (0.45)
3/4	2.52 (64)	3.18 (81)	1.50 (0.68)
	2.95 (75)	3.81 (97)	2.20 (1.00)
1 1/4	3.43 (87)	4.34 (110)	3.40 (1.55)
	4.19 (106)	5.11 (130)	5.40 (2.45)
2	5.04 (128)	6.12 (155)	9.00 (4.09)
	5.97 (152)	7.25 (184)	14.50 (6.59)



**300 CWP • Threaded Cap • Brass/Bronze Disc • Solder Ends**

**1342 Swing Check Valve**

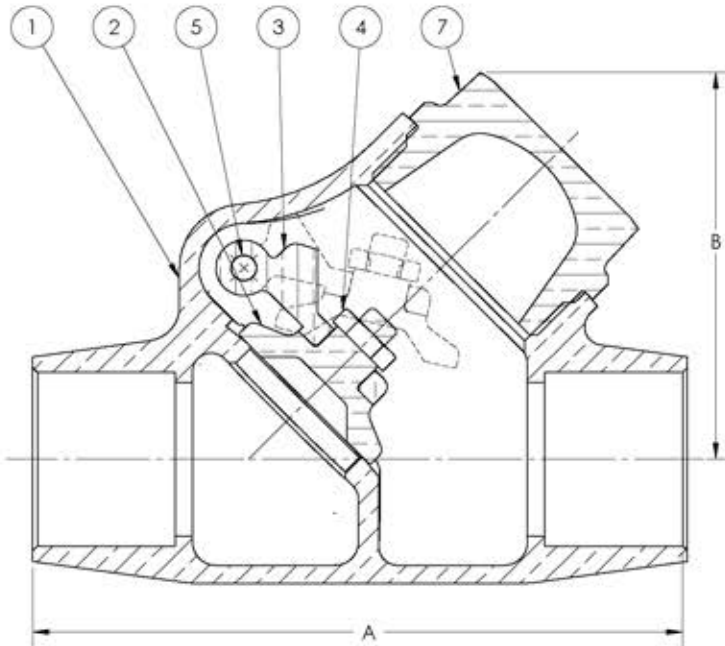

**Materials of Construction**

No.	Description	Material	ASTM Spec.
1	Body	Bronze	B-62 C83600
2	Disc	(1/2" - 3/4") Brass	B-16 H02
		(1" - 2") Bronze	B-61 C92200
		(2 1/2" - 3") Bronze	B-62 C83600
3	Hinge	Bronze	B584 C87600
4	Lock Nut	Brass	B-16 H02
5	Hinge Pin	Stainless Steel	A276 Type 304
6	Hinge Pin Plug	Brass	B-16 H02
7	Cap	Bronze	B-61 C92200

**Caution:** Before installing solder-joint valves, be sure solder or brazing alloy melting point is high enough to withstand line pressure, temperature conditions, and is compatible with fluid medium.

See page 7 for Adjusted Pressure-Temperature Ratings.

**Caution:** Not recommended for use with reciprocating pumps or air compressors in liquid or gas services.

**Industry Standards**

MSS SP-80, Type 3

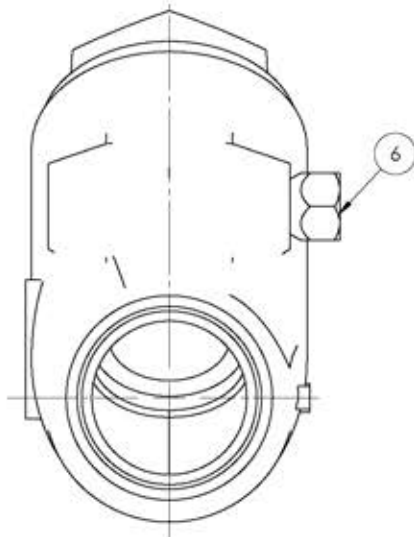

**Dimensions and Weights**

Inches (millimeters) - Pounds (kilograms)

Valve Size	Dimensions		Wt.
	A	B	
1/2	2.70	1.61	0.70
	(69)	(41)	(0.32)
3/4	3.61	1.92	1.10
	(92)	(49)	(0.50)
1	4.25	2.50	1.80
	(108)	(64)	(0.82)
1 1/4	4.82	2.84	2.50
	(122)	(72)	(1.13)
1 1/2	5.60	3.47	4.10
	(142)	(88)	(1.86)
2	6.86	4.17	6.40
	(174)	(106)	(2.90)
*2 1/2	7.78	5.00	10.60
	(198)	(127)	(4.81)
*3	9.31	5.90	15.90
	(236)	(150)	(7.21)

**Class 150 • Threaded Cap • PTFE Disc • Threaded Ends**

**141TF Swing Check Valve**

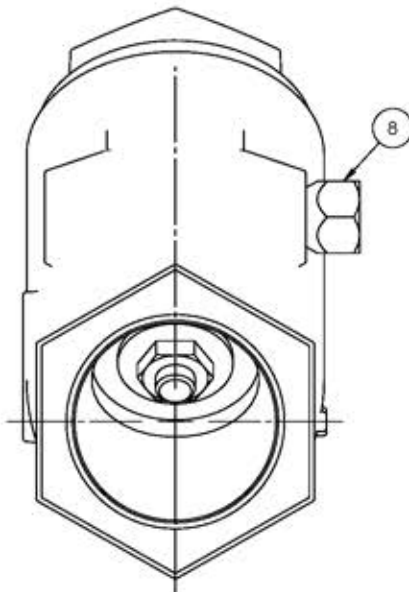
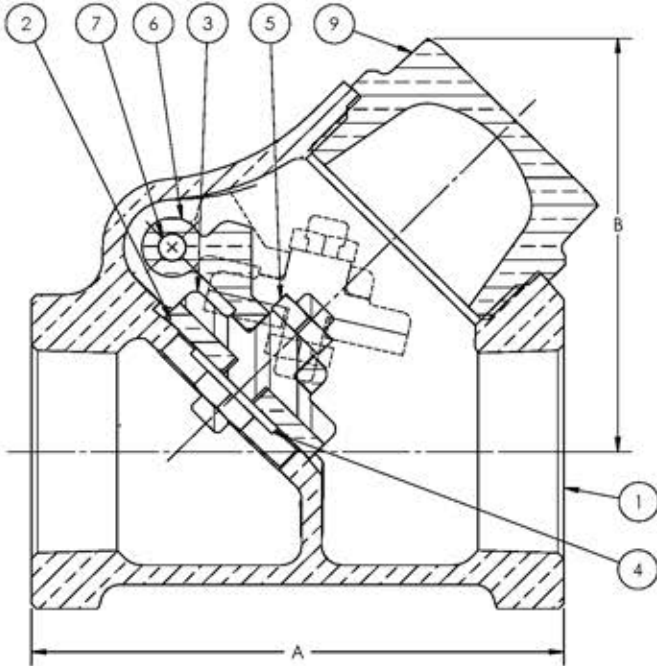

**Materials of Construction**

No.	Description	Material	ASTM Spec.
1	Body	Bronze	B-62 C83600
2	Disc	PTFE/15% Glass Filled	
3	Disc Holder	(1/2" - 3/4") Brass (1" - 2") Bronze	B-16 H02 B-62 C83600
4	Disc Washer	Brass	B-16 H02
5	Lock Nut	Brass	B-16 H02
6	Hinge	Bronze	B-584 C87600
7	Hinge Pin	Stainless Steel	A276 Type 304
8	Hinge Pin Plug	Brass	B-16 H02
9	Cap	Bronze	B-61 C92200

**Caution:** Not recommended for use with reciprocating pumps or air compressors in liquid or gas services. See page 8 for Pressure-Temperature Ratings.

**Industry Standards**

MSS SP-80, Type 4

**Dimensions and Weights**

Inches (millimeters) - Pounds (kilograms)

Valve Size	Dimensions		Wt.
	A	B	
1/2	2.19	1.64	0.70
	(56)	(42)	(0.32)
3/4	2.75	1.92	1.10
	(70)	(49)	(0.50)
1	3.23	2.45	1.80
	(82)	(62)	(0.82)
1 1/4	3.84	2.86	2.60
	(98)	(73)	(1.18)
1 1/2	4.40	3.42	3.90
	(112)	(87)	(1.77)
2	5.18	4.13	6.20
	(132)	(105)	(2.81)

### 36 Swing Check Valve

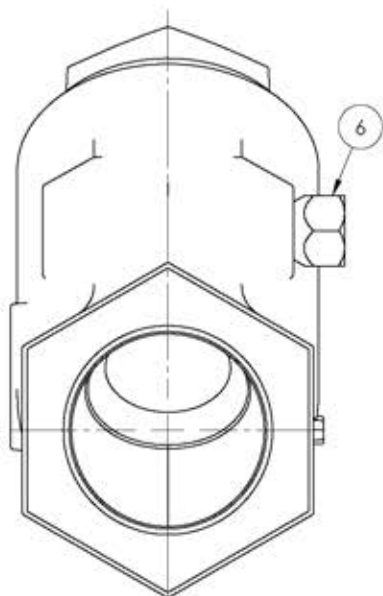
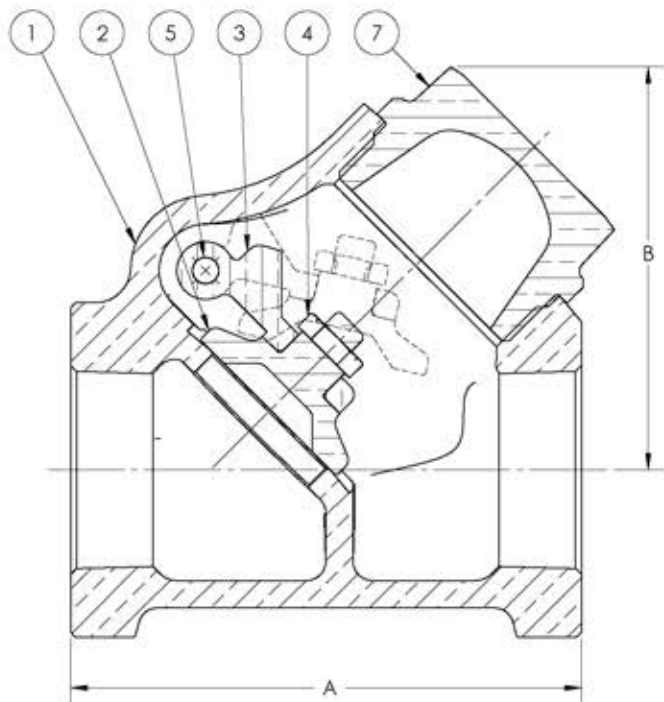

### Materials of Construction

No.	Description	Material	ASTM Spec.
1	Body	Bronze	B-62 C83600
2	Disc	(1/4" - 3/4") Brass	B-16 H02
		(1" - 3") Bronze	B-61 C92200
3	Hinge	Bronze	B-584 C87600
4	Lock Nut	Brass	B-16 H02
5	Hinge Pin	Stainless Steel	A-276 C304
6	Hinge Pin Plug	Brass	B-16 H02
7	Cap	Bronze	B-61 C92200

**Caution:** Not recommended for use with reciprocating pumps or air compressors in liquid or gas services. See page 8 for Pressure-Temperature Ratings.

### Industry Standards

MSS SP-80, Type 3

### Dimensions and Weights

Inches (millimeters) - Pounds (kilograms)

Valve Size	Dimensions		Wt.
	B	A	
1/4	1.49 (38)	2.14 (54)	0.48 (0.22)
	1.49 (38)	2.14 (54)	0.46 (0.21)
1/2	1.64 (42)	2.15 (55)	0.62 (0.28)
	1.92 (49)	2.71 (69)	1.10 (0.50)
1	2.52 (64)	3.18 (81)	1.78 (0.81)
	2.95 (75)	3.81 (97)	2.68 (1.22)
1 1/4	3.43 (87)	4.34 (110)	4.05 (1.84)
	4.19 (106)	5.11 (130)	6.67 (3.03)
2 1/2	4.89 (124)	6.94 (176)	13.00 (5.91)
	5.88 (149)	8.39 (213)	21.67 (9.85)



**200 CWP • Threaded Cap • Brass/Bronze Disc • Solder Ends**

**1340 Swing Check Valve**

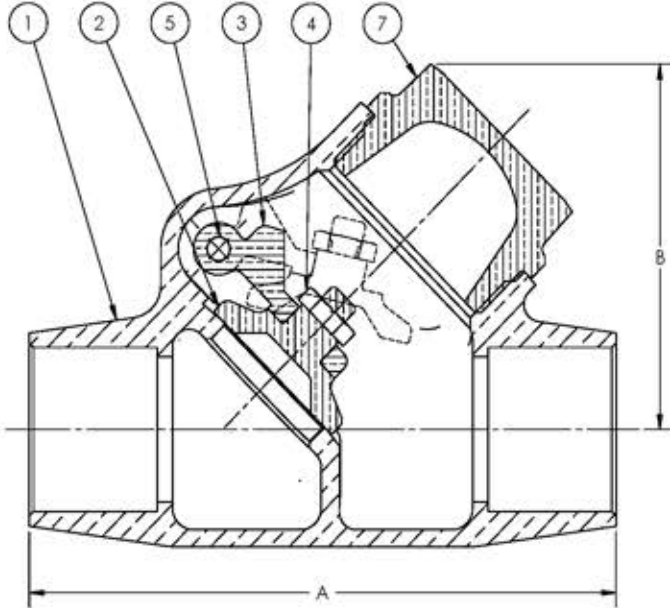

**Materials of Construction**

No.	Description	Material	ASTM Spec.
1	Body	Bronze	B-62 C83600
2	Disc	(1/2" - 3/4") Brass	B-16 H02
		(1" - 2") Bronze	B-61 C92200
		(2 1/2" - 3") Bronze	B-62 C83600
3	Hinge	Bronze	B584 C87600
4	Lock Nut	Brass	B-16 H02
5	Hinge Pin	Stainless Steel	A276 Type 304
6	Hinge Pin Plug	Brass	B-16 H02
7	Cap	Bronze	B-61 C92200

**Caution:** Before installing solder-joint valves, be sure solder or brazing alloy melting point is high enough to withstand line pressure, temperature conditions, and is compatible with fluid medium.

See page 7 for Adjusted Pressure-Temperature Ratings.

**Caution:** Not recommended for use with reciprocating pumps or air compressors in liquid or gas services.

Industry Standards
MSS SP-80, Type 3

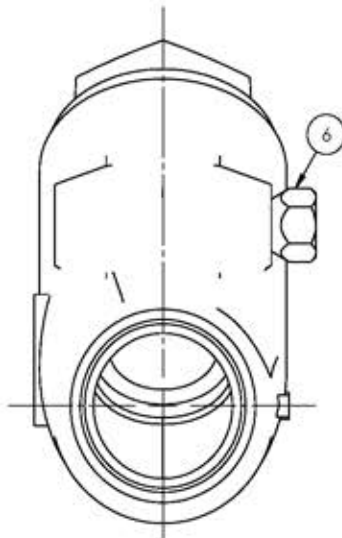

**Dimensions and Weights**

Inches (millimeters) - Pounds (kilograms)

Valve Size	Dimensions		Wt.
	B	A	
1/2	1.64	2.69	0.57
	(42)	(68)	(0.26)
3/4	1.92	3.61	0.95
	(49)	(92)	(0.43)
1	2.52	4.22	1.54
	(64)	(107)	(0.70)
1 1/4	2.95	4.81	2.35
	(75)	(122)	(1.07)
1 1/2	3.43	5.58	3.72
	(87)	(142)	(1.69)
2	4.19	6.85	6.12
	(106)	(174)	(2.78)
2 1/2	5.04	7.78	9.31
	(128)	(198)	(4.23)
3	5.98	9.19	14.10
	(152)	(233)	(6.41)

## Class 300 • Threaded Cap • Brass/Bronze Disc • Threaded Ends

### 76E Swing Check Valve

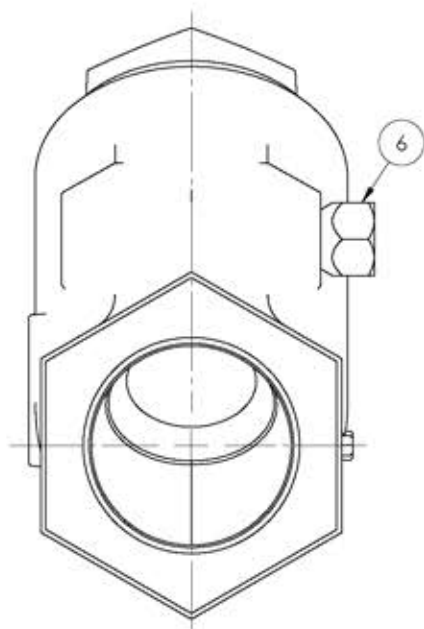
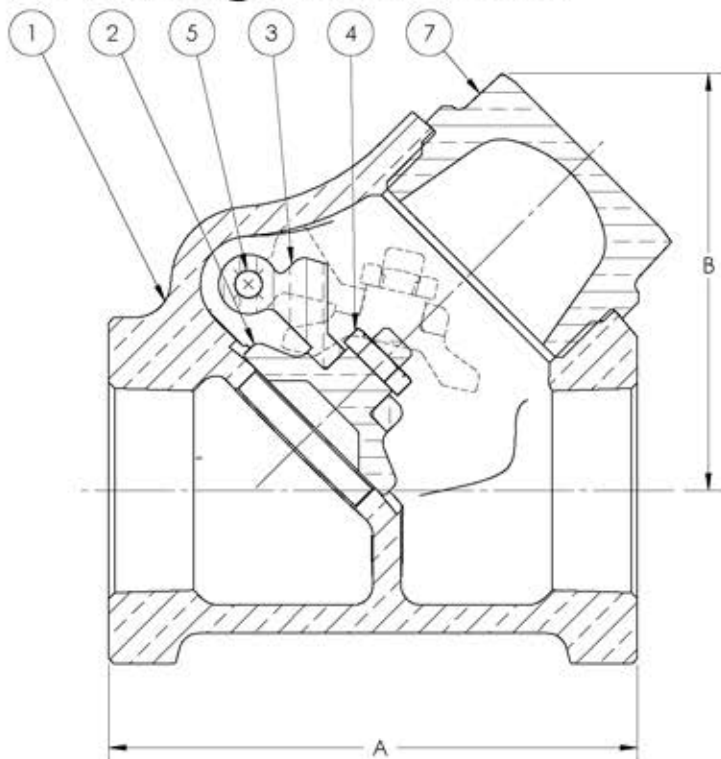

### Materials of Construction

No.	Description	Material	ASTM Spec.
1	Body	Bronze	B-61 C92200
2	Disc	(1/4" - 3/4") Brass	B-16 H02
		(1" - 3") Bronze	B-61 C92200
3	Hinge	Bronze	B-584 C87600
4	Lock Nut	Brass	B-16 H02
5	Hinge Pin	Stainless Steel	A-276 C304
6	Hinge Pin Plug	Brass	B-16 H02
7	Cap	Bronze	B-61 C92200

**Caution:** Not recommended for use with reciprocating pumps or air compressors in liquid or gas services. See page 8 for Pressure-Temperature Ratings.

### Industry Standards

MSS SP-80, Type 3

### Dimensions and Weights

Inches (millimeters) - Pounds (kilograms)

Valve Size	Dimensions		Wt.
	B	A	
1/4	1.49 (38)	2.14 (54)	0.48 (0.22)
	1.49 (38)	2.14 (54)	0.46 (0.21)
1/2	1.64 (42)	2.15 (55)	0.62 (0.28)
	1.92 (49)	2.71 (69)	1.10 (0.50)
1	2.52 (64)	3.18 (81)	1.78 (0.81)
	2.95 (75)	3.81 (97)	2.68 (1.22)
1 1/4	3.43 (87)	4.34 (110)	4.05 (1.84)
	4.19 (106)	5.11 (130)	6.67 (3.03)
2	4.89 (124)	6.94 (176)	13.00 (5.91)
	5.88 (149)	8.39 (213)	21.67 (9.85)

**Class 150 • Union Cap • PTFE Disc • Threaded Ends**

**27TF Lift Check Valve**

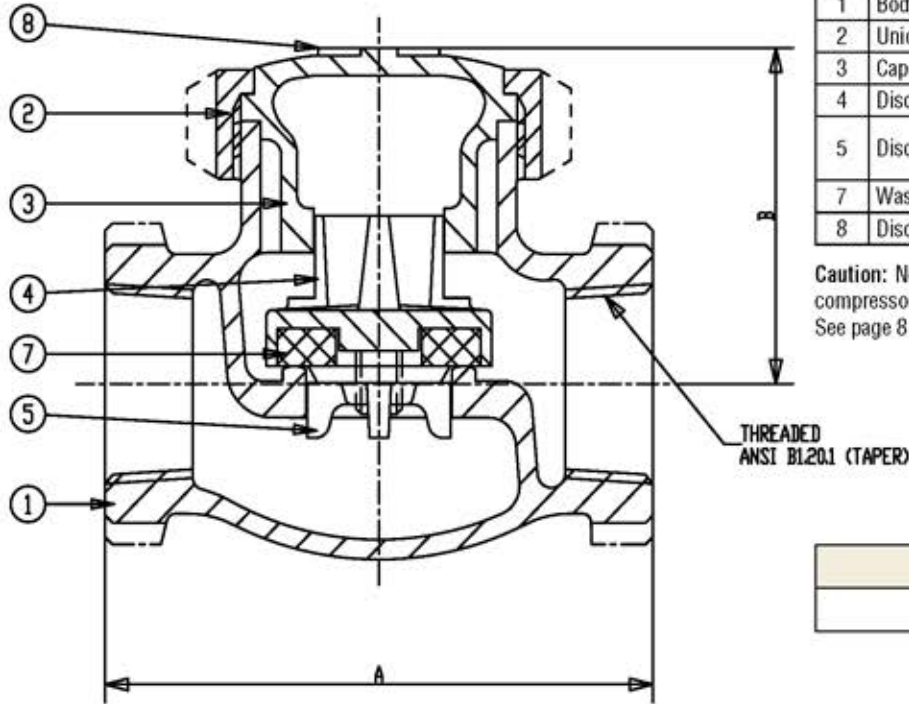

**Materials of Construction**

No.	Description	Material	ASTM Spec.
1	Body	Bronze	B-62 C83600
2	Union Ring	Bronze	B-62 C83600
3	Cap	Bronze	B-62 C83600
4	Disc Holder	Bronze	B-62 C83600
5	Disc Retaining Nut	(1/4" - 3/8") Brass	BSEN12164 CW614N
		(1/2" - 2") Bronze	B-62 C83600
7	Washer	(1/4" - 3/8") Brass	BSEN12164 CW614N
8	Disc	PTFE	

**Caution:** Not recommended for use with reciprocating pumps or air compressors in liquid or gas services.  
See page 8 for Pressure-Temperature Ratings.

Industry Standards
MSS SP-80, Type 2

**Dimensions and Weights**

Inches (millimeters) - Pounds (kilograms)

Valve Size	Dimensions		Wt.
	B	A	
1/4	1.46	2.32	0.82
	(37)	(59)	(0.37)
3/8	1.46	2.32	0.79
	(37)	(59)	(0.36)
1/2	1.69	2.68	1.13
	(43)	(68)	(0.51)
3/4	1.93	3.19	1.87
	(49)	(81)	(0.85)
1	2.21	3.74	2.91
	(56)	(95)	(1.32)
1 1/4	2.56	4.25	4.35
	(65)	(108)	(1.97)
1 1/2	2.87	4.76	5.84
	(73)	(121)	(2.65)
2	3.43	5.75	9.79
	(87)	(146)	(4.44)



## Class 300 • Union Cap • Bronze Disc • Threaded Ends

### 366E Lift Check Valve

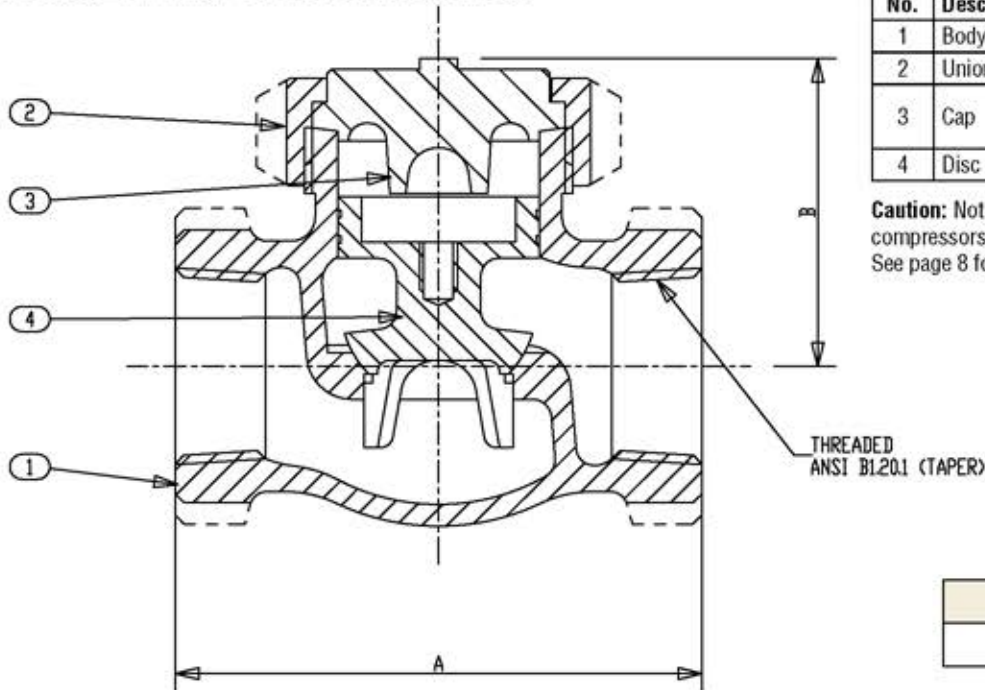

### Materials of Construction

No.	Description	Material	ASTM Spec.
1	Body	Bronze	B-61 C92200
2	Union Ring	Bronze	B-62 C83600
3	Cap	(1/2") Copper Silicon Bronze (3/4" - 2") Bronze	B-371 C69400 B-61 C92200
4	Disc	Bronze	B-61 C92200

**Caution:** Not recommended for use with reciprocating pumps or air compressors in liquid or gas services.  
See page 8 for Pressure-Temperature Ratings.

### Industry Standards

MSS SP-80, Type 1

### Dimensions and Weights

Inches (millimeters) - Pounds (kilograms)

Valve Size	Dimensions		Wt.
	B	A	
1/2	1.46	2.56	1.04
	(37)	(65)	(0.47)
3/4	1.85	2.95	1.70
	(47)	(75)	(0.77)
1	2.05	3.50	2.69
	(52)	(89)	(1.21)
1 1/4	2.36	4.06	4.08
	(60)	(103)	(1.85)
1 1/2	2.64	4.61	5.84
	(67)	(117)	(2.65)
2	3.23	5.75	10.06
	(82)	(146)	(4.56)

**Class 125 • Bronze Cap • Brass/Bronze Disc • Threaded Ends**

**1707 Swing Check Valve**

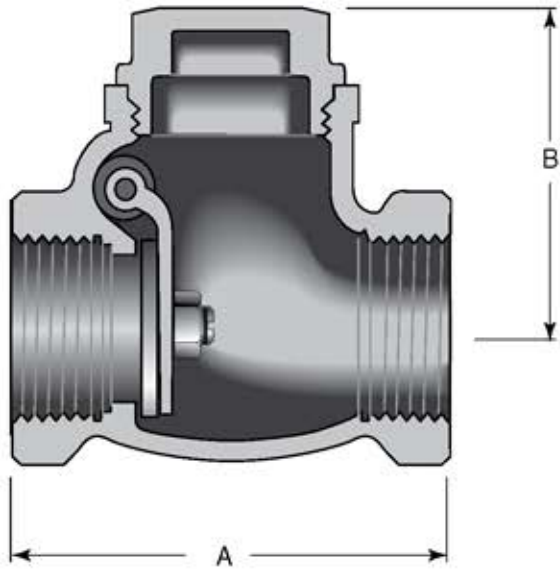

**Materials of Construction**

No.	Description	Material	ASTM Spec.
1	Body	Bronze	B-62 C83600
2	Cap	Bronze	B-16 C83600
3	Disc (1/4" - 3/4")	Bronze	B-16 alloy 360
4	Disc (1" - 3")	Bronze	B-62 C83600

**Caution:** Not recommended for use with reciprocating pumps or air compressors in liquid or gas services.  
See page 8 for Pressure-Temperature Ratings.

Industry Standards
MSS SP-80, Type 3

**Dimensions and Weights**

Inches (millimeters) - Pounds (kilograms)

Valve Size	Dimensions		Wt.
	A	B	
1/4	2.12	1.50	0.70
	(54)	(38)	(0.32)
3/8	2.12	1.50	0.70
	(54)	(38)	(0.32)
1/2	2.60	1.77	0.80
	(66)	(45)	(0.36)
3/4	2.76	1.93	1.00
	(70)	(49)	(0.45)
1	3.27	2.28	1.40
	(83)	(58)	(0.63)
1 1/4	3.78	2.56	2.70
	(96)	(65)	(1.22)
1 1/2	4.25	2.86	2.90
	(108)	(73)	(1.31)
2	5.04	3.50	4.40
	(128)	(89)	(1.98)
2 1/2	6.30	4.25	7.60
	(160)	(108)	(3.42)
3	7.08	4.84	9.30
	(180)	(123)	(4.19)

**200 CWP • Bronze Cap • Brass/Bronze Disc • Solder Ends**

**1707S Swing Check Valve**

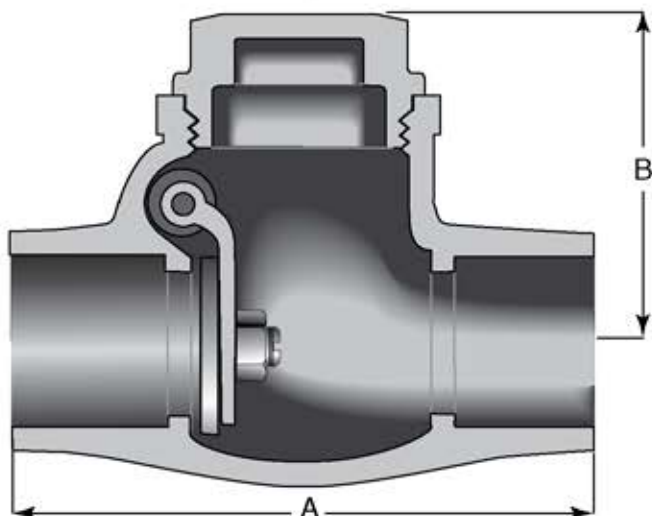

**Materials of Construction**

No.	Description	Material	ASTM Spec.
1	Body	Bronze	B-62 C83600
2	Cap	Bronze	B-16 C83600
3	Disc (3/8" - 3/4")	Bronze	B-16 alloy 360
4	Disc (1" - 3")	Bronze	B-62 C83600

**Caution:** Before installing solder-joint valves, be sure solder or brazing alloy melting point is high enough to withstand line pressure, temperature conditions, and is compatible with fluid medium.

See page 7 for Adjusted Pressure-Temperature Ratings.

**Caution:** Not recommended for use with reciprocating pumps or air compressors in liquid or gas services.

**Industry Standards**

MSS SP-80, Type 3

**Dimensions and Weights**

Inches (millimeters) - Pounds (kilograms)

Valve Size	Dimensions		Wt.
	A	B	
3/8	2.28	1.50	0.60
	(58)	(38)	(0.27)
1/2	2.60	1.77	0.80
	(66)	(45)	(0.36)
3/4	3.23	1.93	0.90
	(82)	(49)	(0.41)
1	3.86	2.28	1.40
	(98)	(58)	(0.63)
1 1/4	4.49	2.56	2.50
	(114)	(65)	(1.13)
1 1/2	5.12	2.86	2.80
	(130)	(73)	(1.26)
2	6.14	3.50	4.20
	(156)	(89)	(1.90)
2 1/2	7.25	4.25	7.20
	(184)	(108)	(3.25)
3	8.07	4.84	8.80
	(205)	(123)	(3.97)



# Bronze Lead Free Valve Index

<b>Bronze Lead Free Valves</b>	
<b>Gate Valves</b>	
200 CWP .....	48-49
<b>Swing Check Valves</b>	
200 CWP .....	50-51

**200 CWP • Threaded Bonnet • Solid Disc • Threaded Ends**

**LF438 Lead Free Gate Valve**

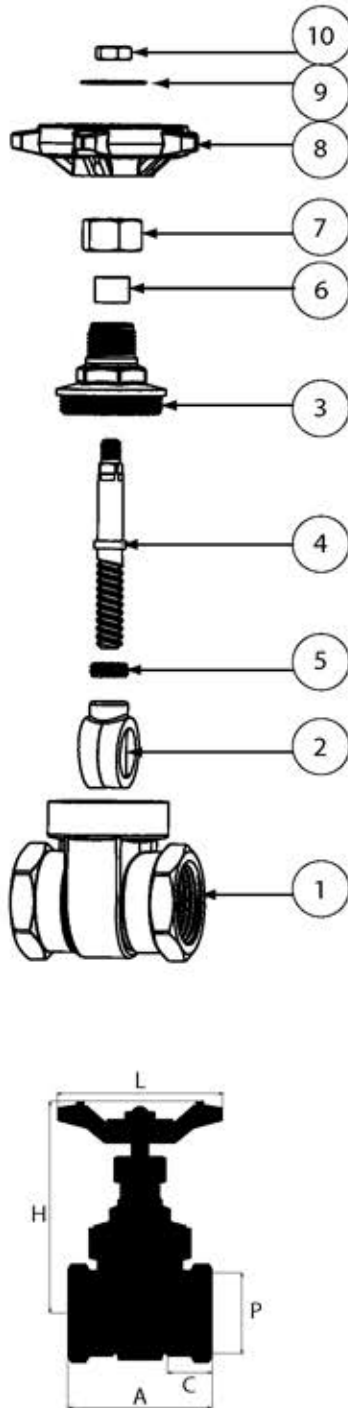

**Materials of Construction**

No.	Description	Material	Specification
1	Body	Lead Free Brass	CW510L
2	Wedge	Lead Free Brass	CW510L
3	Bonnet	Lead Free Brass	CW510L
4	Stem	Lead Free Brass	CW510L
5	Ring	Lead Free Brass	CW510L
6	Packing Ring	Graphite	WRAS Approved
7	Packing Nut	Brass	BS2874 CZ122
8	Handwheel	Aluminum	B85 Red Painted
9	Disc	Aluminum	B85
10	Nut	Zinc Plated Steel	A36

See page 8 for Pressure-Temperature Ratings.

**Industry Standards**

California's AB1953

NSF61 Annex G

**Dimensions and Weights**

Inches (millimeters) - Pounds (kilograms)

Valve Size	Dimensions					Wt.	Cv
	A	C	H	L	P		
½	1.97	0.65	2.79	2.51	0.51	0.53	10.8
	(50)	(17)	(71)	(64)	(13)	(0.24)	
¾	2.12	0.65	3.17	2.51	0.74	0.82	23
	(54)	(17)	(81)	(64)	(19)	(0.37)	
1	2.44	0.78	3.93	2.99	1.00	1.17	42
	(62)	(20)	(100)	(76)	(25)	(0.53)	
1 ¼	2.75	0.86	4.37	3.54	1.25	1.83	72
	(70)	(22)	(111)	(90)	(32)	(0.83)	
1 ½	2.84	0.86	4.94	3.54	1.50	2.38	120
	(72)	(22)	(125)	(90)	(38)	(1.08)	
2	3.23	0.86	6.27	4.13	2.00	4.03	210
	(82)	(22)	(159)	(105)	(51)	(1.82)	

**00 CWP • Threaded Bonnet • Solid Disc • Solder Ends**

**LF1320 Lead Free Gate Valve**

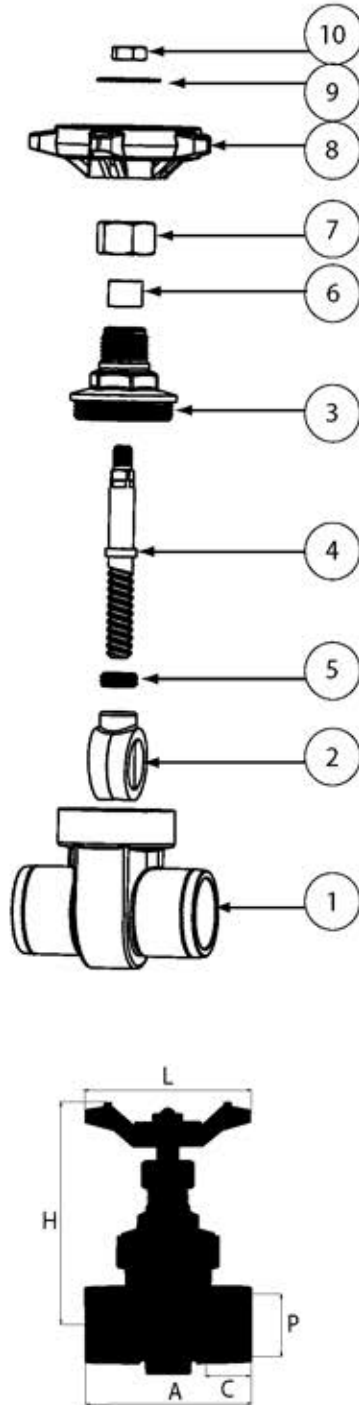

**Materials of Construction**

No.	Description	Material	Specification
1	Body	Lead Free Brass	CW510L
2	Wedge	Lead Free Brass	CW510L
3	Bonnet	Lead Free Brass	CW510L
4	Stem	Lead Free Brass	CW510L
5	Ring	Lead Free Brass	CW510L
6	Packing Ring	Graphite	WRAS Approved
7	Packing Nut	Brass	BS2874 CZ122
8	Handwheel	Aluminum	B85 Red Painted
9	Disc	Aluminum	B85
10	Nut	Zinc Plated Steel	A36

**Caution:** Before installing solder-joint valves, be sure solder or brazing alloy melting point is high enough to withstand line pressure, temperature conditions, and is compatible with fluid medium. See page 7 for Adjusted Pressure-Temperature Ratings.

Industry Standards
California's AB1953
NSF61 Annex G

**Dimensions and Weights**

Inches (millimeters) - Pounds (kilograms)

Valve Size	Dimensions					Wt.	Cv
	A	C	H	L	P		
1/2	1.97	0.65	2.79	2.51	0.51	0.53	10.8
	(50)	(17)	(71)	(64)	(13)	(0.24)	
3/4	2.12	0.65	3.17	2.51	0.74	0.82	23
	(54)	(17)	(81)	(64)	(19)	(0.37)	
1	2.44	0.78	3.93	2.99	1.00	1.17	42
	(62)	(20)	(100)	(76)	(25)	(0.53)	
1 1/4	2.75	0.86	4.37	3.54	1.25	1.83	72
	(70)	(22)	(111)	(90)	(32)	(0.83)	
1 1/2	2.84	0.86	4.94	3.54	1.50	2.38	120
	(72)	(22)	(125)	(90)	(38)	(1.08)	
2	3.23	0.86	6.27	4.13	2.00	4.03	210
	(82)	(22)	(159)	(105)	(51)	(1.82)	



200 CWP • Y-Pattern • Bronze Disc • Solder Ends

**LF1340 Lead Free Swing Check Valve**

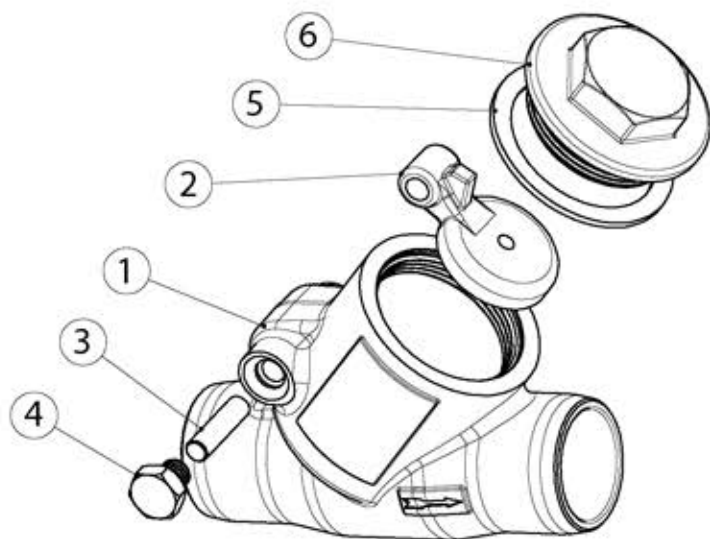

**Materials of Construction**

No.	Description	Material
1	Body	AB1953 Brass 0T60
2	Retaining Disc	AB1953 Brass 0T57
3	Stem	AB1953 Brass 0T57
4	Screw	AB1953 Brass 0T57
5	Gasket	PTFE AE/2
6	Cap	AB1953 Brass 0T57

**Caution:** Before installing solder-joint valves, be sure solder or brazing alloy melting point is high enough to withstand line pressure, temperature conditions, and is compatible with fluid medium. See page 7 for Adjusted Pressure-Temperature Ratings.

**Caution:** Not recommended for use with reciprocating pumps or air compressors in liquid or gas services.

**Industry Standards**

California's AB1953

NSF61 Annex G

**Dimensions and Weights**  
Inches (millimeters) - Pounds (kilograms)

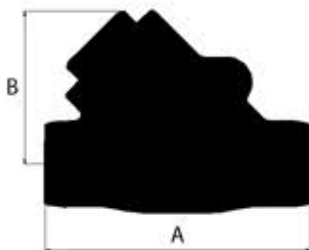

Valve Size	Dimensions		Wt.
	A	B	
½	2.60	1.65	0.35
	(66)	(42)	(0.16)
¾	3.39	1.97	0.87
	(86)	(50)	(0.40)
1	4.09	2.28	1.33
	(104)	(58)	(0.60)
1 ¼	4.72	2.71	2.04
	(120)	(69)	(0.93)
1 ½	5.35	3.19	2.80
	(136)	(81)	(1.27)
2	6.69	3.86	4.78
	(170)	(98)	(2.16)

**200 CWP • Y-Pattern • Bronze Disc • Threaded Ends**

**LF37 Lead Free Swing Check Valve**

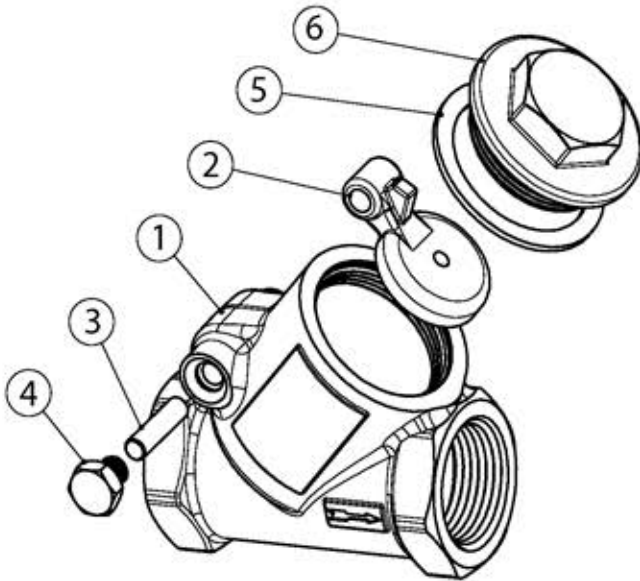

**Materials of Construction**

No.	Description	Material
1	Body	AB1953 Brass 0T60
2	Retaining Disc	AB1953 Brass 0T57
3	Stem	AB1953 Brass 0T57
4	Screw	AB1953 Brass 0T57
5	Gasket	PTFE AE/2
6	Cap	AB1953 Brass 0T57

**Caution:** Not recommended for use with reciprocating pumps or air compressors in liquid or gas services.  
See page 8 for Pressure-Temperature Ratings.

**Industry Standards**

California's AB1953  
NSF61 Annex G

**Dimensions and Weights**  
Inches (millimeters) - Pounds (kilograms)

Valve Size	Dimensions		Wt.
	A	B	
½	2.21	1.65	0.58
	(56)	(42)	(0.26)
¾	2.76	1.97	0.93
	(70)	(50)	(0.42)
1	3.15	2.28	1.37
	(80)	(58)	(0.62)
1¼	3.78	2.71	2.15
	(96)	(69)	(0.98)
1½	4.33	3.19	2.97
	(110)	(81)	(1.35)
2	5.04	3.86	4.82
	(128)	(98)	(2.18)

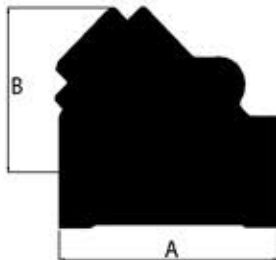

**CRANE**

CRANE Energy Flow Solutions®

# **FLOSOURCE**

VALVES | ACTUATION | INSTRUMENTATION | STEAM SPECIALTIES

**800-752-5959**

**sales@flosource.com**



brands you trust.



**COMPAC-NOZ**

**CRANE**

**DUO-CHEK**



**NOZ-CHEK**



**STOCKHAM**



**UNI-CHEK**

**NUCLEAR**

**VALVE SERVICES**

EG-CR-CT-EN-L16-02-1206 (CV-301)

Crane Co., and its subsidiaries cannot accept responsibility for possible errors in catalogues, brochures, other printed materials, and website information. Crane Co. reserves the right to alter its products without notice, including products already on order provided that such alteration can be made without changes being necessary in specifications already agreed. All trademarks in this material are property of the Crane Co. or its subsidiaries. The Crane and Crane brands logotype (Aloyco®, Center Line®, Compac-Noz®, Crane®, Duo-Chek®, Flowseal®, Jenkins®, Krombach®, Noz-Chek®, PacificValves®, Stockham®, Triangle®, Uni-Chek®) are registered trademarks of Crane Co. All rights reserved.