

## Series 32/33 Wafer

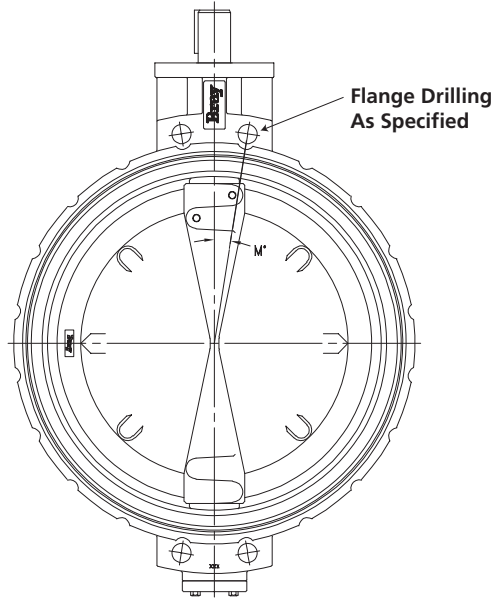
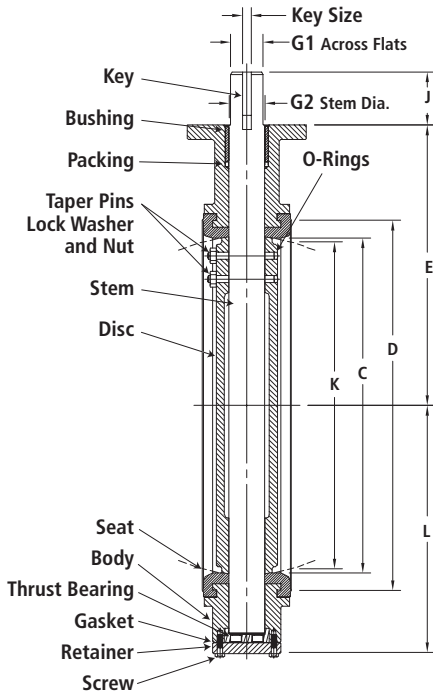

IMPERIAL DIMENSIONS: Inches																				
Valve Size	A	B	C	D	E	F	Mounting Flange Drig.			G2	SERIES 32				SERIES 33				L	Weight (lbs.)
							PCD	No. Holes	Hole Dia.		G1	J	Key Size	K	G1	J	Key Size	K		
22	25.50	6.06	21.27	24.12	20.12	8.27	6.50	4	.81	2.50	2.50	4.00	.62x.62	20.51	2.50	4.00	.62x.62	20.56	16.56	400
24	27.94	5.94	23.28	25.75	19.50	8.27	6.50	4	.81	2.50	2.50	4.00	.62x.62	22.65	2.50	4.00	.62x.62	22.70	17.56	420
26	29.50	6.50	24.46	27.83	21.83	11.81	10.00	8	.71	2.50	2.50	4.00	.62x.62	23.71	2.50	4.00	.62x.62	23.76	18.82	540
28	31.11	6.50	26.46	29.83	22.84	11.81	10.00	8	.71	2.50	2.50	4.00	.62x.62	25.74	2.50	4.00	.62x.62	25.78	19.83	580
30	34.13	6.56	29.29	32.14	23.00	11.81	10.00	8	.71	3.00	2.50	4.00	.62x.62	28.68	3.00	4.00	.75x.75	28.73	20.81	660
32	35.55	7.48	30.39	33.78	26.38	11.81	10.00	8	.71	3.00	2.50	4.00	.62x.62	29.59	3.00	4.00	.75x.75	29.65	21.94	785
34	38.75	7.88	33.00	35.82	26.93	13.78	11.73	8	.81	3.50	3.00	4.00	.75x.75	32.18	3.50	5.25	.88x.62	32.22	23.66	905
36	40.69	7.88	35.30	38.25	27.75	13.78	11.73	8	.81	3.50	3.00	4.00	.75x.75	34.57	3.50	5.25	.88x.62	34.62	24.94	1025

Note: K dimension is disc chordal dimension at valve face.

METRIC DIMENSIONS: Millimeters																				
Valve Size	A	B	C	D	E	F	Mounting Flange Drig.			G2	SERIES 32				SERIES 33				L	Weight (kg)
							PCD	No. Holes	Hole Dia.		G1	J	Key Size	K	G1	J	Key Size	K		
550	648	154	540	611	511	210	165	4	21	63.5	63.5	101.6	18x11	521	63.5	101.6	18x11	522	419	181
600	710	151	591	654	495	210	165	4	21	63.5	63.5	101.6	18x11	575	63.5	101.6	18x11	576	446	191
650	749	165	621	707	554	300	254	8	18	63.5	63.5	101.6	18x11	601	63.5	101.6	18x11	602	478	245
700	790	165	672	756	580	300	254	8	18	63.5	63.5	101.6	18x11	654	63.5	101.6	18x11	655	502	263
750	868	167	744	813	584	210	165	4	18	76.2	63.5	101.6	18x11	728	76.2	101.6	20x12	730	529	299
800	903	190	772	856	670	300	254	8	18	76.2	63.5	101.6	18x11	751	76.2	101.6	20x12	752	556	356
850	984	200	838	908	684	350	298	8	21	88.9	76.2	101.6	20x12	817	88.9	133.4	22x14	818	599	411
900	1034	200	899	972	705	273	216	8	21	88.9	76.2	101.6	20x12	817	88.9	133.4	22x14	879	633	465

Note: K dimension is disc chordal dimension at valve face.

Drawings are for reference only. Please refer to Bray ES drawings on the Bray website, [www.bray.com](http://www.bray.com). Bray reserves the right to change product dimensions without notice.

### SR Drawing #32/33-22/36-in

Customer/Project: \_\_\_\_\_

Inquire/P.O. No.: \_\_\_\_\_

Bray Order No.: \_\_\_\_\_