

Table 2: Torque Requirements

Retainer Torque (+ or - 10%) (ft-lb)	Valve Size	Retainer Torque (+ or - 10%) (ft-lb)
BRONZE	Valve Size	STEEL
13	1/4" - 3/8"	13
16	1/2"	16
42	3/4"	42
63	1"	63
130	1-1/4"	130
199	1-1/2"	199
282	2"	282
686	2-1/2"	681
905	3"	905



A Division of Conbraco Industries, Inc. Matthews, NC Pageland, SC Conway, SC

ACTUATOR READY BALL VALVES 71ARX64, 76ARX64, 77ARX64 and 89ARX64 INSTALLATION, OPERATION, & MAINTENANCE GUIDE

PARTS ILLUSTRATION

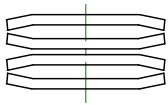
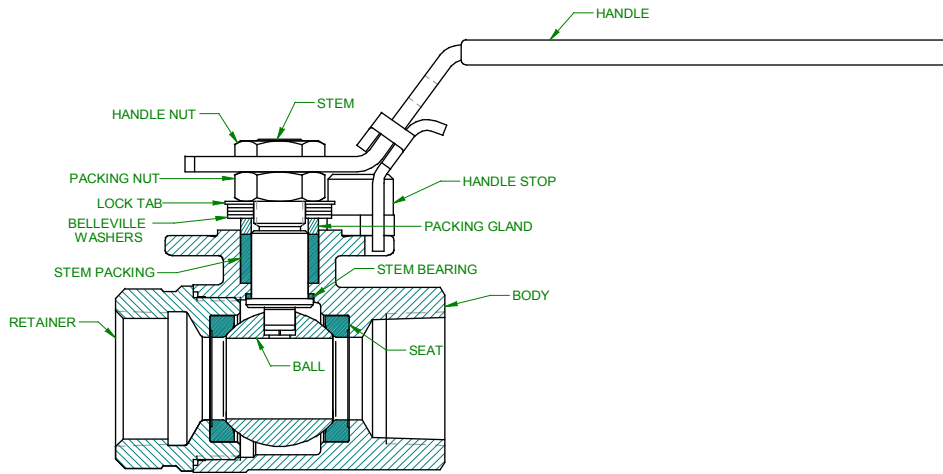

BELLEVILLE WASHERS ASSEMBLY
WASHERS SHOULD BE STACKED AS SHOWN.
IF ONLY (1) SET IS REQUIRED, THEN PLACE
AS THE ONE SHOWN ON TOP.



INSTALLATION

Valves must be installed in piping systems that comply with the applicable portions of the ASME B31 standards. Special considerations must be taken with respect to pipe line expansions and contractions and the media expansion and contractions within the piping system.

Threaded End Valves

Pipe connections to be threaded into these valves should be accurately threaded, clean and free of foreign material or metal shavings. PTFE pipe tape is recommended for use as the pipe joint sealant. Two wrenches must be used when making up pipe joints to these valves. Apply one wrench on the valve end closest to the pipe joint being tightened and the other wrench to the pipe to prevent transmitting torque through the valve body joint. Typical pipe make-up is 1-1/2 turns after installing the pipe hand-tight.

OPERATION

Handle Operation:

The valve handle is marked showing proper rotation direction for "ON" and "OFF" positions. Rotation is clockwise for "OFF" (closed) and counterclockwise for "ON" (open).

Actuator Operation:

The valve is "ON" when the red indicator plugs on the actuator are aligned (i.e. parallel) with the piping and actuator body. Conversely, when the red indicators plugs are perpendicular to the piping and actuator body, the valve is "OFF" and no flow condition is indicated.

MAINTENANCE

Regular Maintenance

Normal stem packing wear can be compensated for by tightening the packing gland screw. (Wrench part number H371400 is available to ease this operation.) Tighten the packing gland screw clockwise in 1/8 turn increments until observed leakage stops. Do not exceed the values shown in Table 1. If all of the adjustments to the packing gland screw have been made, remove the handle nut, handle and packing gland screw and add one or two replacements bearings on top of the old packing. Reinstall the handle and handle nut.

Caution: Do not disassemble valve while under pressure nor with entrapped hazardous fluids therein.

Valve Repair

Disassembly

- 1) Operate the valve fully opened to fully closed to assure there are no trapped fluids or pressure in the body cavity. Leave the valve in the closed position.
- 2) Bend down the tab on lock plate and remove nut by rotating counterclockwise. Remove locking tab, Belleville washers and gland ring from stem. Set aside all components for reuse except for the lock plate. Lock plate may be thrown away, a replacement is provided in the Service Kit.
- 3) Install pipe plugs in the body and retainer ports of NPT valves to prevent collapsing those areas.
- 4) Remove the retainer from the body. It may be necessary to heat the body joint above 450°F to breakdown the sealant used to secure the valve halves.

- 5) Remove the ball from the body cavity. Inspect the ball. If it is scarred, it is recommended that the whole valve be replaced, but replacement balls are available. Clean and set aside good balls for reuse.
- 6) Push the stem from the outside into the body cavity. Inspect the stem. If it is scarred or has damaged threads, replacements are available. Clean and set aside good stems for reuse.
- 7) Remove all seals and seats from the body and retainer then discard. Inspect the body and retainer for damage. If damaged, scrap the valve as replacements of these components are not offered.

Re-Assembly

- 1) Install stem bearing on to stem.
- 2) Fit stem into body from the retainer end and position the stem with the handle flats perpendicular to the flow axis.
- 3) Install stem packing over stem and fit into body recess.
- 4) Install gland ring, Belleville washers, lock plate (new) and stem nut.
- 5) Tighten the stem nut clockwise to the torque specifications shown in Table 1.

Table 1: Stem Nut Torque

Valve Size	Stem Nut Torque (in-lbs)
1/4" - 1/2"	50
3/4" - 1-1/4"	75
1-1/2" - 3"	150

- 6) Bend a tab up on the locking plate so that it captures the flat of the stem nut.
- 7) Apply suitable light lubricant to seat and fit into the seat pocket of the body.
- 8) Install the ball in the closed position.
- 9) Apply suitable light lubricant to seat and fit into the seat pocket of the retainer.
- 10) Apply an adequate amount of thread locking compound (Loctite ® 609, 648 or 680) to the retainer threads so that it covers no less than two complete threads opposite of the retainer shoulder.

Note: Valves in oxygen service can only be sealed with oxygen compatible thread sealant.

- 11) With the ball in the closed position, thread the retainer into the body and torque to manufacturing specification to secure the body joint. Tightened to torque values shown in Table 2.
- 12) Cycle the valve to the open position and verify proper operation and alignment of handle and/or mechanism.

Note: Always test valve and system before putting the system into service.