

SENSORS FOR FOOD AND LIFE SCIENCES.



SANITARY BY DESIGN

ANDERSON-NEGELE



PRODUCT OVERVIEW

LIFE SCIENCES

ENGLISH 

-  TEMPERATURE
-  PRESSURE
-  LEVEL
-  POINT LEVEL
-  FLOW
-  CONDUCTIVITY
-  TURBIDITY
-  WEIGHING SYSTEMS
-  PROCESS ADAPTERS

[ANDERSON-NEGELE.COM](https://www.anderson-negele.com)



Warrants for trouble-free processes

For many years, our customers in the pharmaceutical industry and in biotechnology have trusted in sensors and measurement systems from Anderson-Negele.





Durable and reliable: The processes in highly sensitive production lines eliminate the risk of introducing foreign substances from the outside. Maintenance and repair measures must have little or no impact on the process. This is particularly true of sensors and measurement equipment integrated in the line – and relates to features such as the sensor material, surface quality, dead-leg-free design and pharmaceutical process adaptation.

Aseptic by design – at any moment: The quality requirements specific to the pharmaceutical industry are grouped under the term "aseptic design", which is a concept that extends beyond international sanitary regulations.

- » Installation in all common pipe standards (DIN, ISO, ASME)
- » All process-contacting parts made of stainless steel 1.4435 or 316L
- » Acceptance certificate 3.1 as per EN 10204
- » Electropolished surface from $R_a \leq 0.8 \mu\text{m}$ up to $0.2 \mu\text{m}$ (30 up to 8 microinches)
- » Surface inspection certificate (on demand)
- » Delta-ferrite measurement report (on demand)
- » Elastomers and plastics with USP Class VI approval

CONTENTS

SENSORS FOR THE PHARMACEUTICAL INDUSTRY AND BIOTECHNOLOGY.	
TEMPERATURE	2 - 3
POINT LEVEL / CONTINUOUS LEVEL	4
CONTINUOUS LEVEL / PRESSURE	5
PRESSURE	6 - 7
FLOW	8 - 9
CONDUCTIVITY / TURBIDITY	10
	11

-  Sensor based on modular platform
-  IO-Link integrated as a standard
-  Remote version available
-  R_a 0.X: Max. surface roughness in μm (electropolished)
-  Pipes from DN10 (ISO8 / ASME 1/4")

Pharma production. ASEPTIC BY DESIGN

For maximum performance and results, you need not only highly efficient and precise sanitary sensors, but also perfectly matching solutions for process connection, control and communication. Anderson-Negele offers trend-setting solutions for this as well:

PHARMadapt EPA – Sensors for reduced spaces: The process adaptation system PHARMadapt integrates temperature and point level sensors even in pipes with very small nominal widths. The seal with exchangeable O-rings meets the technical requirements for lines in the pharmaceutical industry.

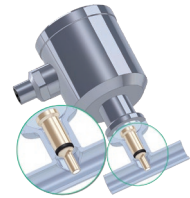

PHARMadapt ESP – Sensors without medium contact: If the temperature sensors are not permitted to come into direct contact with the medium and the process should not be opened, the PHARMadapt ESP system developed by Anderson-Negele is the optimal solution for your line. Adapters and compatible temperature sensors are available in addition to the complete build-in systems.

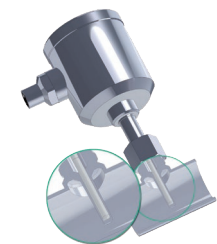

CPM - Sensors for front-flush integration: The CPM technology was developed specifically for the pharmaceutical process adaptation of pressure sensors and gauges for the purpose of taking measurements in pipes with small diameters. CPM technology enables a front-flush mounted, absolutely dead-leg-free measurement location.

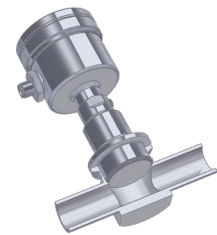

You can find more details on possibilities and benefits of our fitting technologies in our special brochure "Process adapters".

Digital communication: IO-Link allows for a faster, more precise and more substantial data transfer than other interfaces. The "plug-and-play" operation set-up is easy and needs only reduced time and effort. The unique Anderson-Negele "Flex-Hybrid Technology" combines digital IO-Link with analog 4...20 mA communication. This sophisticated platform unifies all existing, proved and tested functions with the benefits of the digital technology. Discover all benefits of digital communication in our special IO-Link brochure.

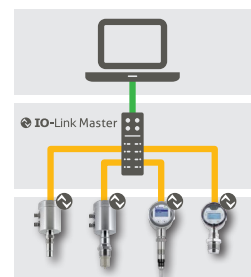

Instrumentation and controls: For rapid and precise installation, simulation, calibration, operation and control of our sensors in your production line we offer a variety of measurement amplifiers, signal transmitters, digital indicators, alarm relays, and field bus integration system, providing an individual and efficient connection to your control technology.





Temperature measurement in aseptic lines



Temperature sensor with aseptic PHARMadapt ESP build-in system

- » Aseptic thermowell system – removal of the sensor without opening the process
- » Rapid response time, very compact measuring point
- » Insensitive to vibrations
- » Electropolished temperature sensor, $R_a \leq 0.8 \mu\text{m}$
 $R_a \leq 0.4 \mu\text{m}$ optional

TS / TFP PHARMadapt ESP

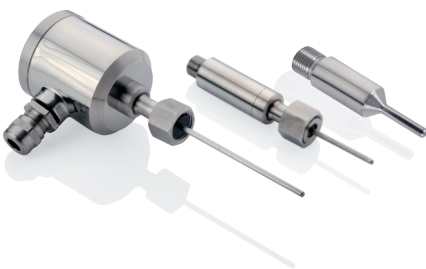

Temperature measurement in very small pipe diameters



Temperature sensor with aseptic PHARMadapt EPA build-in system

- » Dead-leg-free, pharmaceutical measurement location with O-ring
- » For pipe diameters from DN 10
- » Rapid response time, very compact measurement location

TS / TFP PHARMadapt EPA

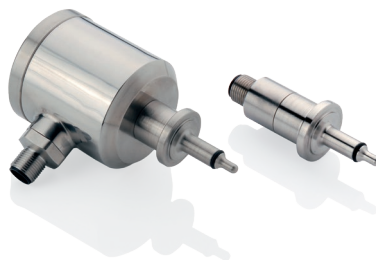

Temperature measurement in bioreactors, pipes and vessels



Temperature sensors and transmitters for all Life Science Applications

- » A wide variety ensures the best possible solution for any requirement
- » Multitude of process connections
- » Single / dual RTD
- » Choice of no, 1 or 2 transmitters
- » Optional with digital display

TSM / SW / CT / TS / FJ

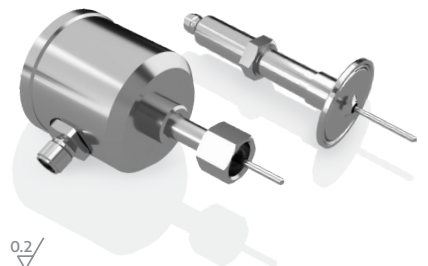



Point level detection in very small pipe diameters



Capacitive point level indicator with aseptic PHARMadapt EPA build-in system

- » Reliable switching also with high viscosity or pasty media
- » Dead-leg-free, pharmaceutical measurement location with O-ring
- » Extremely compact dimension for easy installation
- » Rapid response time < 1s
- » Various process connections for individual configuration

NCS-61P / NCS-81P

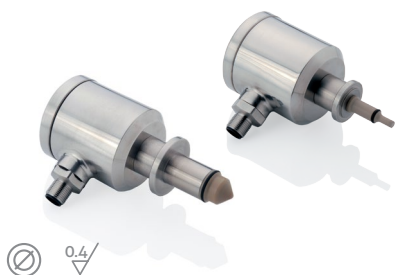

Point level detection in pipes and vessels



Capacitive point level sensor for direct connection

- » Reliable switching also with high viscosity or pasty media
- » Insensitive to foam
- » Short response time < 1 s
- » Also for media with low conductivity such as WFI

NCS-31P

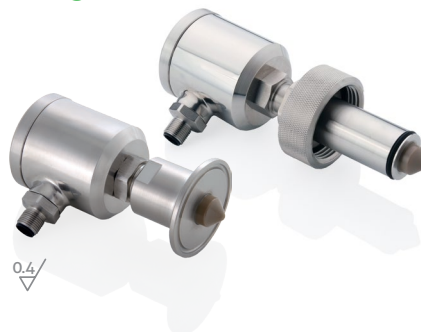

Capacitive point level sensor for vessels

- » Reliable switching even with high viscosity or pasty media
- » Installation in vessels from below or above
- » Probe length up to 200 mm (7.9")
- » Rapid response time
- » Optionally heated electronics to avoid condensation

NCS-L-31P



PHARMA



CONTINUOUS LEVEL / PRESSURE

Pressure and hydrostatic level control in vessels



Modular pressure and level sensor

- » High precision pressure and hydrostatic level measurement
- » Accurate display of pressure, mass or volume even with rapid temperature variations
- » Integrated tank linearization and density compensation

L3P



Hydrostatic level and differential pressure measurement



Level sensor for pressurized tanks / differential pressure sensor

- » Parallel output of differential and head pressure
- » Integrated tank linearization and density compensation
- » Digital communication without capillaries
- » Components' replacement on site possible

D3P



Point level detection in vessels



Capacitive point level sensor for vessels

- » For dielectric media from $\epsilon_K=2$, unaffected by foam
- » Ideal for WFI, Bioreactor monitoring, SIP tank level monitoring
- » Process temperatures up to 143 °C (290 °F)
- » Rod length for vessels up to 3 m
- » Single / dual bend rod available
- » 2-Wire sensor with 4...20 mA and Hart 5.0 output

LA





Hydrostatic level measurement



Pressure measurement in small pipe diameters and vessels



Pressure measurement in pipes and vessels



Climate-independent level sensor

- » Hermetically sealed measuring system
- » Very high accuracy and long-term stability
- » Measurement up to 130 °C (265 °F) medium temperature
- » Intrinsically safe (Class 1, Div. 1)

SX

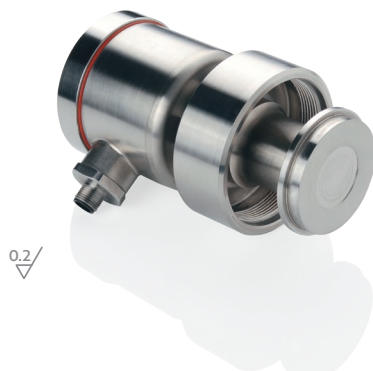

0.2/

Compact pressure sensor with aseptic build-in system

- » Dead-leg free, aseptic process connection with Tri-Clamp or front-flush CPM
- » Nominal pipe widths 1/4" to 4" (ASME)
- » High process temperature up to 150 °C (300 °F)
- » Intrinsically safe (Class 1, Div. 1)
- » Option: Fully autoclaveable (124 °C / 255 °F, 1 h)

HA



0.2/

High-temperature high-accuracy pressure sensor

- » High temperature measurement (up to 204 °C / 400 °F)
- » Standard 4...20 mA output with "HART" protocol
- » Optional LCD display (horizontal or vertical)
- » Intrinsically safe (Class 1, Div. 1)

TPP



0.2/

PHARMA



PRESSURE

Pressure measurement with diaphragm monitoring



Digital in-situ pressure display



Modular pressure sensor

- » For use at process temperatures up to 177 °C (350 °F)
- » Integrated display
- » No tools required for calibration and adjustment
- » Intrinsically safe (Class 1, Div. 1)

MPP



Digital pressure gauge

- » Large digital display (battery-operated)
- » Automatic registration of min and max values
- » Optionally available with switch output and external power supply

EP





Pressure monitoring
in pipes and vessels



Compact pressure gauge 63 mm

- » Extremely robust design for highest requirements
- » Autoclavable
- » Tri-Clamp 3/4", 1" and CPM for pipes with small diameters

EK



Pressure monitoring
in pipes and vessels



Pressure gauge 90 mm

- » Extremely robust design for highest requirements
- » Autoclavable
- » Adjustment of zero and span

EM



PHARMA



FLOW

Flow measurement in flash pasteurizer



Flow measurement of demineralized water



Flow monitoring/ dry-run protection

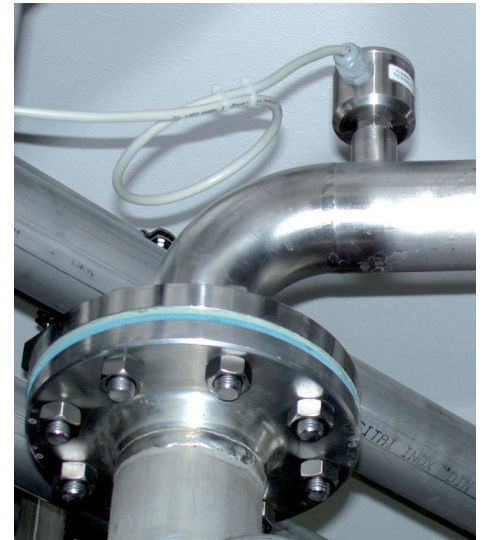

Magnetic-inductive flowmeter

- » Also for low flow rate
- » Long life span due to moisture proof and corrosion resistant design
- » Vacuum tight, rigid tube lining to resist high temperatures
- » Very high measurement accuracy and reproducibility:
 $\pm 0,2 \% \pm 1 \text{ mm/s}$

IZMAG / FMQ



Turbine flowmeter

- » Measurement unaffected by the conductivity of the medium
- » Cost-effective and reliable alternative to mass flow meters
- » Extended lifetime due to easy rotor exchange
- » Hygienic design for pharmaceutical applications

HMP

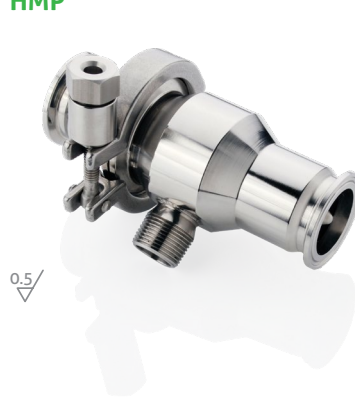

Calorimetric flow switch

- » Fully compensated measurement up to $100 \text{ }^{\circ}\text{C}$ ($212 \text{ }^{\circ}\text{F}$)
- » Integrated safety switch-off at a medium temperature of $t > 100 \text{ }^{\circ}\text{C}$ ($212 \text{ }^{\circ}\text{F}$)
- » Also suitable for highly pure media
- » Integrated electronics with on-site display

FTS



CIP process control

Quality control of products

Phase separation, filter and separator monitoring



Inductive conductivity meter

- » Modular design for flexible configuration
- » Individual configuration from a cost-efficient basic model up to the high end version
- » Freely selectable outputs: Conductivity, temperature and also concentration

Turbidity sensors (backscatter light)

- » Front-flush sanitary design
- » Reduction of water consumption
- » Cost reduction in CIP processes
- » Active phase separation in the production process
- » Glass-free sapphire optics

Turbidity sensors

- » Filter monitoring
- » Control and automation of separators
- » Supervision of the water quality
- » Eventual pollution of the optics is compensated

ILM-4, ILM-4R

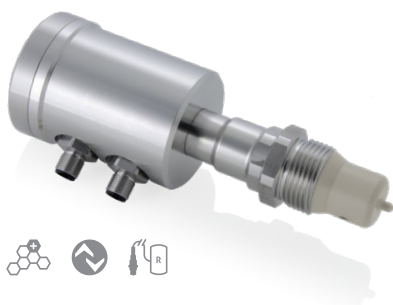

ITM-51, ITM-51R

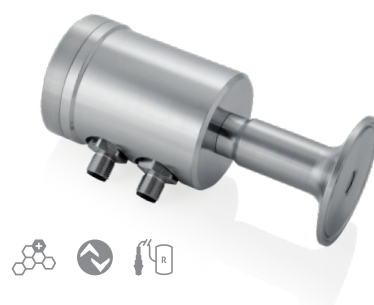

ITM-4





SANITARY BY DESIGN

ANDERSON-NEGELE



NEGELE MESSTECHNIK GMBH

Raiffeisenweg 7
87743 Egg an der Guenz
GERMANY

Phone +49 (0) 83 33 . 92 04 - 0
Fax +49 (0) 83 33 . 92 04 - 49
sales@anderson-negele.com

INTERNATIONAL MAIN OFFICES

Anderson Instrument Company Inc.
Fultonville, NY 12072
USA

Anderson-Negele China
Shanghai, 200335
P.R. CHINA

SPTech
Tamboré - Barueri - São Paulo
BRASIL

Anderson-Negele India
Kurla, Mumbai – 400 070
INDIA